

Handbuch Band 1

Brüstungs- und Geländersysteme

balustrade and railing systems

Vordach- und Überkopfverglasung

canopy and overhead glazing

Fassaden- und Punkthaltersysteme

facade and point-fixed systems

Glassysteme im Innenbereich

indoor glas system

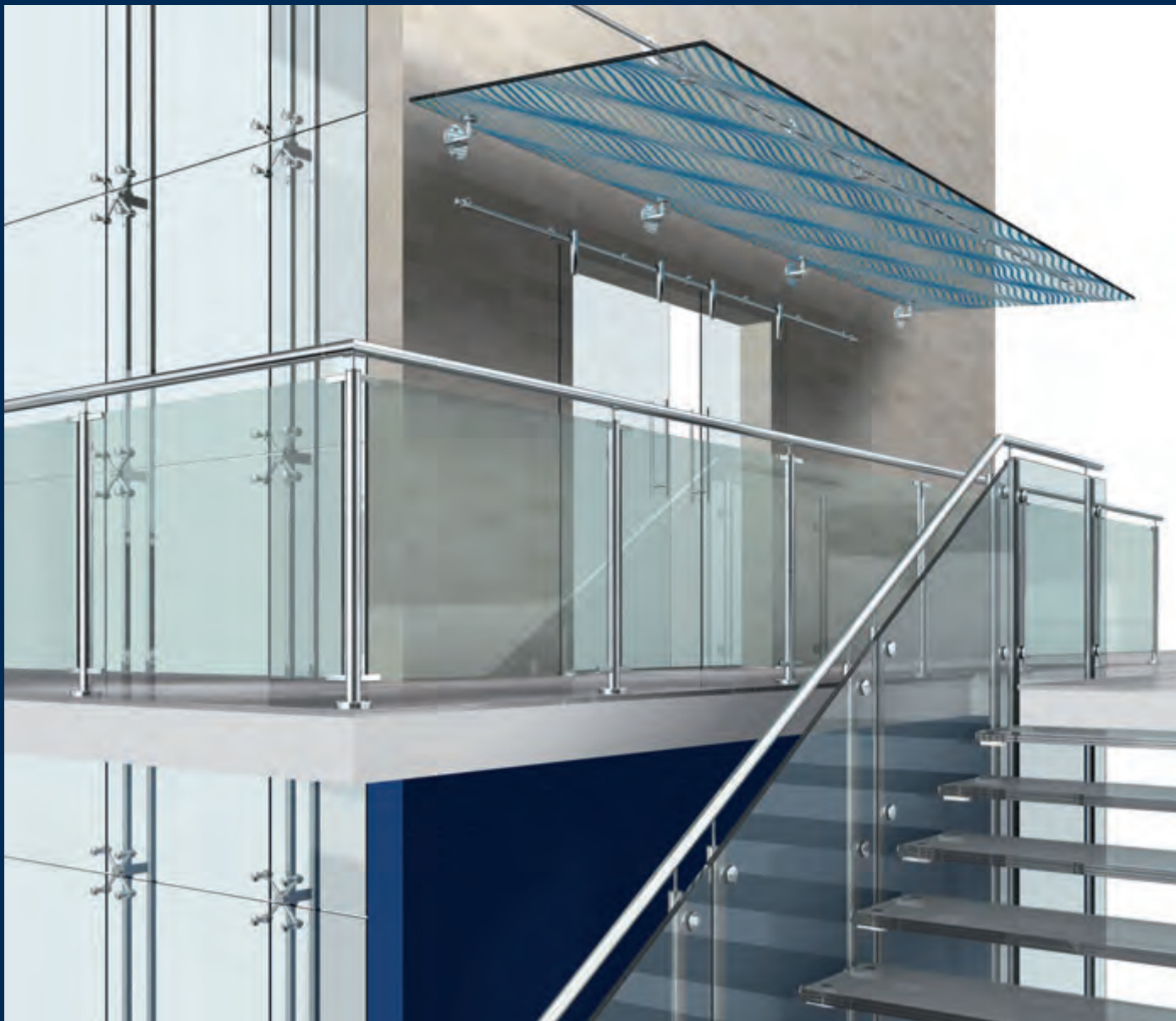

DEUTSCHE METALL®



■ Thomas Sixt, Geschäftsführer deutscheMetall GmbH

Die neue DEUTSCHE METALL – Lernen Sie uns neu kennen, erleben Sie uns ganz anders.

Wir begleiten Sie bei Ihren Aufgaben. Nutzen Sie unsere Ausstellung, lassen Sie sich weiterbilden in neuen Geschäftsbereichen und profitieren Sie von unserer kompetenten CAD-Planung von Objekten.

Wir versprechen nichts ... wir beweisen es!

DEUTSCHE METALL 2010 bedeutet: **Schnelle Lieferung** (lesen Sie mehr auf Seite 6), **Hohe Verfügbarkeit** (lesen Sie mehr auf Seite 4), **Professionelle Beratung** (lesen Sie mehr auf Seite 5)

Nehmen Sie uns beim Wort!

The new DEUTSCHE METALL – Get acquainted with us and experience us newly.

We accompany you in your tasks. Use our showroom and learn more from us in new fields of business. Gain from our competent CAD object planning.

We promise nothing... we are proofing it!

DEUTSCHE METALL 2010 means: **fast delivery** (see more on page 6), **high stock availability** (see more on page 4), **professional support** (see more on page 5)

Take us at our word!

Hohe Verfügbarkeit

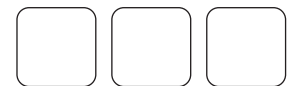

fast delivery

high availability

Professionelle Beratung

Schnelle Lieferung









professional support



- DeutscheMetall GmbH 4
 bequem bestellen - professionell beraten - prompt liefern und einfach bezahlen | order convenient - professional support - prompt delivery, easy payment

Brüstungs- und Geländersysteme10
 balustrade and railing systems









- Produkte | products12
- Bemessung und Sicherheit | design and safety 208

| | | |
|---|---|---|
|  |  |  |
|  |  |  |
|  |  |  |



Vordach- und Überkopfverglasung 250
 canopy and overhead glazing









- Produkte | products 252
- Bemessung und Sicherheit | design and safety 330

| | | |
|--|--|--|
|  |  |  |
|  |  |  |
|  |  |  |



Fassaden- und Punkthalterssysteme 378
 facade and point-fixed systems









- Produkte | products 380
- Bemessung und Sicherheit | design and safety 446

| | | |
|---|---|---|
|  |  |  |
|  |  |  |
|  |  |  |



Glassysteme im Innenbereich 486
 indoor glass systems

- Schiebetürsystem PS200 | sliding door system PS200 488
- Profile | profiles 510
- Ganzglasduschen | glass showers 524

| | | |
|---|---|---|
|  |  |  |
|  |  |  |
|  |  |  |



- Chemisch-technische Produkte | chemical-technical products ... 608
- Index, Service, Infos | index, T&C, service, info 612



■ Bequem bestellen ... | order convenient...

... beim qualifizierten Fachhandel, bei unseren ausgewählten Vertriebspartner oder direkt bei DEUTSCHE METALL Mannheim und Radebeul. | ... at your qualified specialist, from our chosen sales partner or directly from DEUTSCHE METALL Mannheim and Radebeul.

Bestellungen bei DEUTSCHE METALL Mannheim können getätigt werden ...

per Telefon 0621 / 39 72 42-0
für schnelle Bestellungen und fachmännische Beratung.
Sie erreichen uns
Mo.-Fr. von 7:15 Uhr bis 17:00 Uhr.

per Fax 0800-36 38 255
kostenfrei auf unserem Bestellfax.

per Internet www.deutschemetall.com
einfach und schnell, 24 Stunden am Tag, bestellen Sie in unserem Onlineshop www.deutschemetall.com. Hier erhalten Sie auch eine sofortige Auskunft über die Verfügbarkeit der bestellen Artikel.

Auf unsere Homepage unter www.deutschemetall.com finden Sie in der Rubrik Vertriebsnetz die Adressen unserer Vertriebspartner. Verteilt über das gesamte Bundesgebiet sowie in Teilen von Polen, Frankreich, Luxemburg und Belgien, distribuieren wir unsere Produkte über sorgfältig ausgewählte Handelspartner. Wir möchten so sicherstellen, dass unsere Kunden ihren Warenbedarf deutschlandweit auf kurzem Weg und zum gleichen Preis decken können. Haben Sie Fragen zu unseren Produkten und deren Anwendungen, dann finden Sie bei unseren Vertriebspartnern kompetente Beratung. Durch regelmäßige Produktschulungen vor Ort oder in unserem Schulungszentrum in Mannheim ist das Know-how unserer Partner immer auf dem aktuellsten Stand. Bitte beachten Sie die abweichenden Liefer- und Zahlungsbedingungen vom teilnehmenden Fachhandel.

Orders may be placed at DEUTSCHE METALL...

by phone +49 621 / 39 72 42-0
For quick orders and professional support.
You could reach us from Mo. – Fr. from 7:15 am until 5:00 pm

by Fax under +49 800 - 36 38 255
By using our gratis order fax.

on the internet www.deutschemetall.com
For quick and easy orders visit our online shop under www.deutschemetall.com. Immediate availability information of ordered goods is given while ordering.

You will find the addresses of our sales partners on our website www.deutschemetall.com under „sales network“. We are distributing our articles via chosen trade partners all over Germany and in some parts of Poland, France, Luxemburg and Belgium. We would like to ensure that our customers will be able to order our goods on the shortest way at the same price. Should you have any questions about our products and their applications you will get professional support from our sales partners. With regular product training at site and in our new training centre in Mannheim we are keeping the know-how of our sales partners always up to date. Please be aware of the differing payment and delivery conditions of our sales partners.

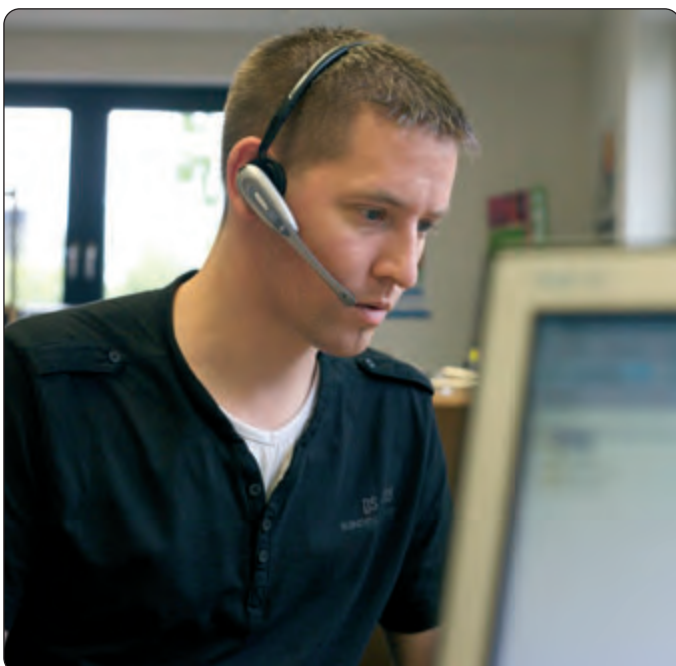

■ S. Freudenberg, Verkauf Innendienst DM GmbH | S. Freudenberg, sale office DM GmbH



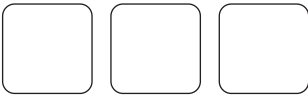

■ Professionell beraten | professional support

Beratung und Unterstützung bei Objektgeschäften Fon: +49 621 / 39 72 42-15
Advice and support for object business under phone +49 621 / 39 72 42-15

Bei unseren Fachleuten für Objektgeschäfte erhalten Sie Antworten zu Produkten. Sie finden professionelle Unterstützung bei der Planung von Objekten und deren Umsetzbarkeit bis hin zu gesetzlichen Vorschriften. Sie möchten Ihre Planung in einer 3D-Ansicht. Hier finden Sie die richtigen Ansprechpartner.

Our specialists for object business will answer your questions to our products. You will get professional support for the planning and the realization of your objects as well as comprehensive information about the statutory provisions. You wish to get an 3-dimensional plan of your project? No problem! You will find the right contact person here.

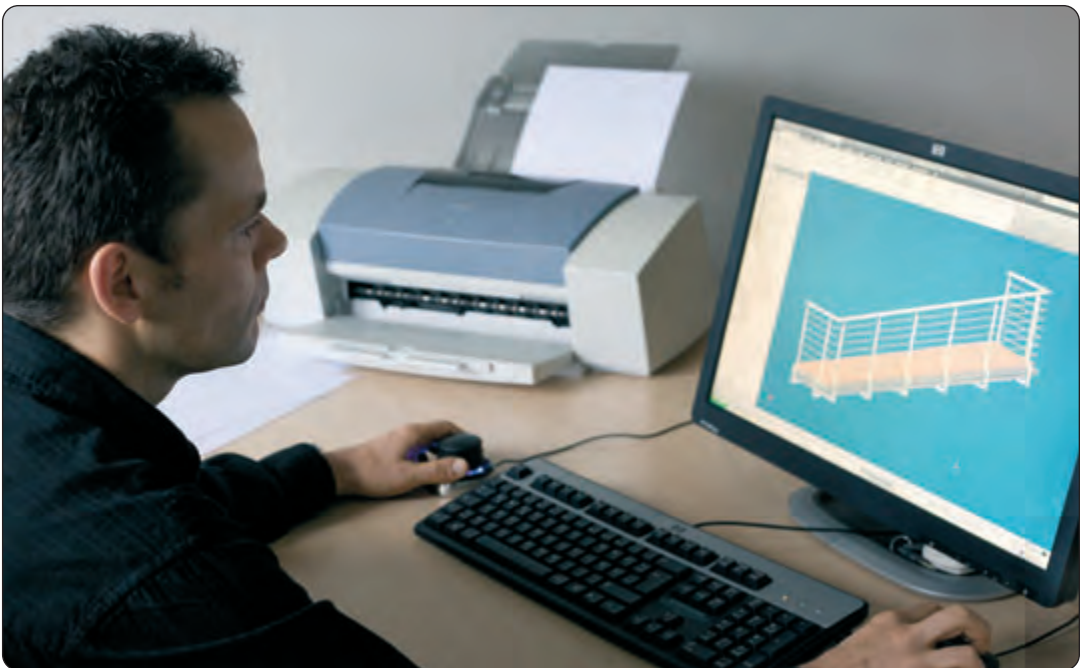

■ B. Weggler, Entwicklung und Konstruktion | B. Weggler, development and construction DM GmbH

Hohe Verfügbarkeit

Fast delivery

Professionelle Beratung

Schnelle Lieferung

Beratung

professional support

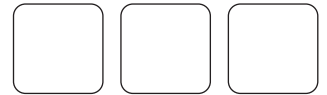

■ ... promptly delivered | ... promptly delivery

Innerhalb Deutschlands erfolgen alle Lieferungen „FREI HAUS“. Ausnahme: Sonderanfertigungen, Stangenmaterial und Ronden. Hier werden 5 % Frachtaufschlag auf den Netto Warenwert erhoben; mind. 20,00 €. Dies gilt auch für Kombinationsaufträge bei denen Standardware und z. B. Stangenmaterial bestellt werden.

Alle Lagerartikel ☺^{24h} liefern wir, wenn Sie bis 12:00 Uhr bestellen, noch am gleichen Tag aus, d. h. je nach Laufzeit der Speditionen ist die Bestellung am nächsten Tag bei Ihnen.

Sollten wir mal nicht in der Lage sein innerhalb 24 Stunden zu versenden (gilt nur für Artikel mit ☺^{24h} Lagerartikel), dann erhalten Sie alternativ ein höherwertiges Produkt zum gleichen Preis angeboten oder **10 % Nachlass** auf den fehlenden Artikel für die Wartezeit!

Lieferungen in die EU sind mit länderspezifischen Frachtaufschlägen belegt, diese nennen wir Ihnen gerne auf Anfrage.

Lieferungen außerhalb der EU werden individuell kalkuliert, wir freuen uns auf Ihre Anfragen.

Delivery shall be effected franco domicile within Germany. Excluded from this arrangement are custom-made products, special packing (oversize), bar material and round blanks; here we shall surcharge 5 % on top of the net buying amount; minimum 20,00 €. This is also valid for combination orders where standard goods and e. g. postes are ordered.

☺^{24h} Orders which are placed till 12:00 am, are leaving our stock at the same day, which means – depending on the forwarding agent – your order will be delivered the following day.

In case we are not able to deliver within 24 hours (☺^{24h} valid only for stock products), we will provide either a replacing product of even higher quality or grant a 10 % price reduction on the price of the ordered product to compensate your time of waiting!

EU-shipments are charged with special freight charges which will be indicated on request.

Shipments outside the EU are calculated individually. We are pleased to receive your request.



Hohe Verfügbarkeit

fast delivery

high availability

Professionelle Beratung

Schnelle Lieferung

professional support



■ ... und einfach bezahlen | ... easy payment

Soweit nicht anders schriftlich vereinbart, sind unsere Rechnungen 20 Tage nach Rechnungsstellung ohne Abzug zahlbar.

Wir belohnen Schnellzahler bei Zahlung innerhalb von 10 Tagen nach Rechnungsdatum mit 2 % Skonto auf den Nettowarenwert.

Möchten Sie Ihren Auftrag direkt bei uns abholen, dann erhalten Sie einen Abholrabatt von 6 %, dies gilt für Mannheim, Dresden-Radebeul und PL-Palowice.

Kunden die Einzugsermächtigung erteilen werden mit einem 4 % Skonto belohnt!
Gewährte Preisnachlässe entfallen bei Zahlungsverzug.

Unless otherwise agreed, our invoices are payable without any discount 20 days after

We shall grant a discount of 2 % on invoices which are paid within 10 days after presentation of the invoice.

Customers who collect the goods themselves from our stocks in Mannheim, Dresden-Radebeul or PL Palowice shall receive a collection discount of 6 %.

For customers who grant us a direct debit mandate we offer a 4 % discount!
The granted discount/reductions shall no longer apply if payment is delayed.

■ ... Allgemeine Regelungen - bitte beachten! | ... general conditions – please consider

Mindermengenzuschlag: Wir berechnen einen Mindermengenzuschlag bei Auftragswerten (netto) unter 100,00 € in Höhe von 8,50 €.

Verpackungsmaterial: Berechnen wir pauschal mit 3,99 € je Auftrag, somit haben Sie hier eine klare Kalkulationsbasis und keine versteckten Kosten.

Rohstoffzuschläge: Die Rohstoffpreise sind wie uns die letzten Monate gezeigt haben, sehr variabel. Wir behalten uns bei nachweislich steigenden Rohstoffpreisen temporäre Preisanpassungen mittels eines Rohstoffzuschlages (RZ) vor. Diese werden positionsbezogen ausgewiesen.
Alle Maßangaben sind zirka-Maße. Irrtümer und technische Änderungen vorbehalten.

AGB: Wir arbeiten ausschließlich auf der Basis unserer Allgemeinen Geschäftsbedingungen neuester Stand. Diese erhalten Sie unter www.deutschemetall.de/AGB. Abweichende Regelungen finden nur Anwendung, wenn sie ausdrücklich und schriftlich von unserer Seite bestätigt wurden.

Surcharge for quantities below minimum: 8,50 € surcharge will be charged for order value (net) under 100,00 €

Packing material: On each order we add a fee of 3,99 € for packing material. This gives you a clear calculation basis and you are not surprised by hidden cost.

Raw material surcharge: Prices for raw materials are very fluctuating. Therefore we are reserving the right to debit temporary corresponding surcharges for raw materials. In that case, we will indicate these surcharges for each order position.

All indicated measurements are circa-measurements. Errors and changes excepted.

General Terms and Conditions: is the latest version of our general Terms and Conditions of Business. You will find our Terms and Conditions on our homepage www.deutschemetall.de/AGB. All agreements reached between us and the contracting party upon conclusion of the contract must be set down in writing and be confirmed from us.



■ K. Werder, Leitung Buchhaltung DM GmbH | K. Werder, Head of Accounting DM GmbH



□ Standorte | locations



DEUTSCHE METALL Zentrale
deutscheMetall GmbH
Boehringerstraße 2a
D-68307 Mannheim
Fon +49 621 - 39 72 42 - 0
Fax +49 621 - 39 72 42 - 20
Email: info@deutschemetall.de
Internet: www.deutschemetall.de



MegaTool
Scheurestraat 13
B-9850 Nevele-Landegem
Fon +32 9 - 371 73 62
Fax +32 9 - 371 66 18
Email: info@megatool.be
Internet: www.deutschemetall.com



DEUTSCHE METALL
Vertriebsgesellschaft Ost GmbH
Kötitzer Straße 25a
D-01445 Radebeul/Dresden
Fon +49 351 - 2 72 23 44
Fax +49 351 - 2 72 24 00
Email: radebeul@deutschemetall.com
Internet: www.deutschemetall.com

DEUTSCHE METALL Polska Sp. z o. o.
ul. wiejska 60a
44-246 Palowice
Fon +48 32 - 42 19 487
Fax +48 32 - 43 17 592
Email: deutschemetallpolska@wp.pl
Internet: www.deutschemetall.pl

□ im Internet | internet

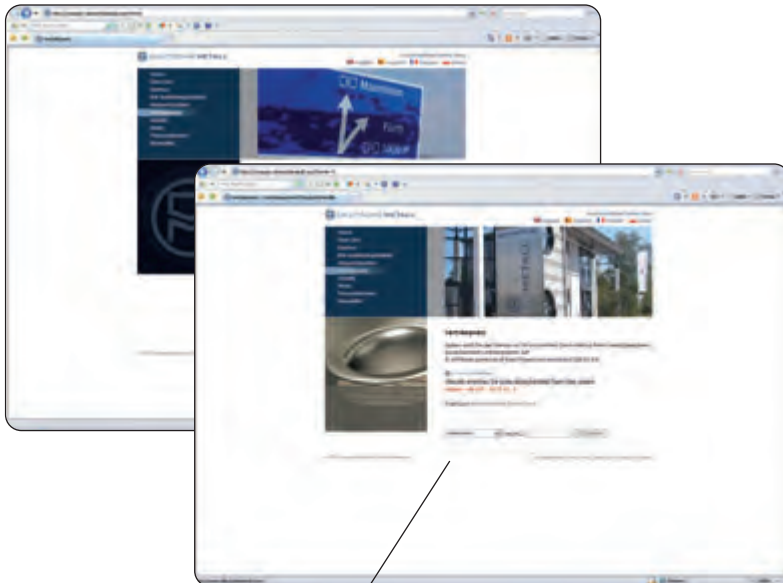

Im Internet unter www.deutschemetall.com finden Sie unser Vertriebspartner-Netz. Hier können Sie bequem einen Anbieter von DEUTSCHE METALL Produkten in Ihrer Nähe wählen.



Anfahrt zur Zentrale in Mannheim | directions to headquarters

On our homepage www.deutschemetall.com you will find our network of sales partners – Here you will easily find the right sales partner of DEUTSCHE METALL products around the corner.





Weiteres Informationsmaterial | more information

Gerne senden wir Ihnen weiteres Informationsmaterial zu.
Bitte kopieren, ausfüllen und faxen an: Fax: 0800 -3638-255

We would be pleased to send you further information.
Please copy, complete and fax it to +49 800 36 38 255

Handbuch | catalogue

Band 1 Band 2

Preisliste price list Preisliste price list



Der DeutscheMetaller | sales flyer

05_09 02_08
 03_09 aktuell | current
 02_09



Duschen | showers

Anwendungsflyer | brochure

Papillon Pontere
 Torsio Vivere
 Farfalla Pillango



Flyer Sicherheit | brochure security

Punkthalter | fixed point systems



Leporello | fanfold

Duschen | showers
 Vordach | canopy

Produktbücher | books of products

Ansichtssache
 Eingangsmatten-Systeme



Ihre Daten | your data:

Kundennummer | customer number

Firma | company

Ansprechpartner | contacts

Straße | street

PLZ, Ort | ZIP code, city

Telefon | phone

E-Mail

Bitte informieren Sie mich per Newsletter | information newsletter
 Bitte informieren Sie mich über Ihre Schulungsprogramme
please send me information material about your training programme



□ Inhalt | content



- Klemmbefestigungen | clamp fixtures 12
- Klemmbefestigungen für vorgesetzte Montage 33
clamp fixture for fascia mounting
- Brüstungsverglasung mit cp-mini | balustrade glazing with cp-mini 46
- Brüstungsverglasung mit TRAV-Haltern
balustrade glazing according to TRAV 52
- Brüstungsverglasung mit Banano | balustrade glazing with Banano 58
- Zubehör | accessories 64



- Rohre und Stäbe | tubes and bars 70
- Endkappen und Anschweißdeckel 74
end caps and welding caps
- Handlaufträger und Zubehör 80
handrail supports and accessories
- Rohrverbinder und Zubehör 98
tube connectors and accessories

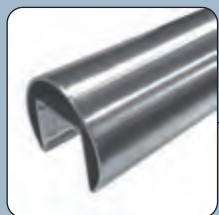

- Geländerpfostenhalter 110
balustrade post brackets
- Ronden, Ankerplatten und Laschen 118
round plates, anchors and brackets
- Nutrohrsysteme | slotted tube systems 124
- Holzhandlaufsysteme 132
wooden handrail systems



- Geländersystemteile 140
balustrade system parts
- Geländersystemteile poliert 150
balustrade system parts polished
- Seilsysteme | cable systems 164
- Designstäbe | design bar infills 184
- Biegearbeiten / Geländer & Rahmen 192
bending work / banisters & frames
- Fertigpfostenprogramm 200
prefabricated posts
- Bemessung und Sicherheit 208
design and safety

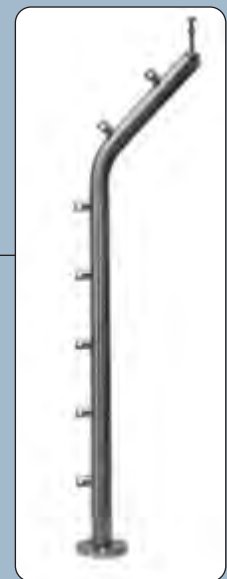

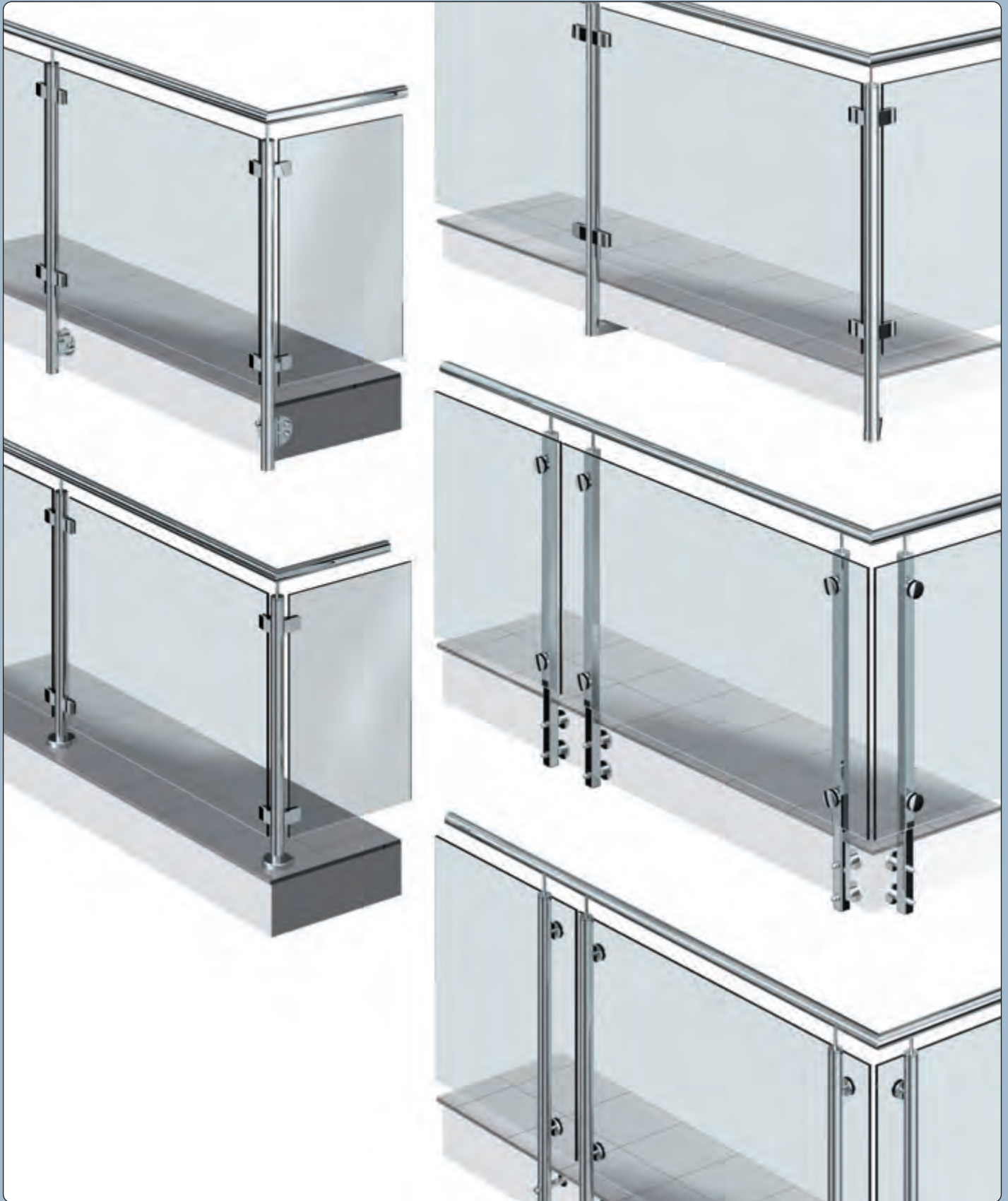

Brüstungs- und Geländersysteme
balustrade and railing systems





So finden Sie schnell Ihr Produkt | how to find your product quickly



1 Auf Seite 3 finden Sie die Aufteilung des Handbuchs in 4 Bereiche. Die Seitenangabe markiert den Start der Rubrik mit den jeweiligen Inhaltsverzeichnissen. | The structure of this handbook, which is divided into 4 sections, is described on page 3. The page reference indicates the start of the category with the respective table of contents.

Sollten Sie einen bestimmten Artikel suchen, finden Sie ab Seite 622 das Artikelnummernverzeichnis, mit deren Seitenangabe.

If you are looking for a specific item, you will find the list of item numbers with page references from page 622 onwards.

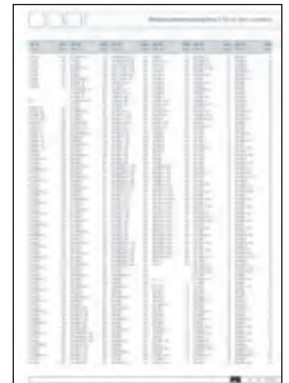

2 Auf Seite 10 finden Sie das detailliertere Inhaltsverzeichnis der Brüstungsrubrik. Seitenangaben führen Sie zu den gesuchten Produkten.

A detailed table of contents for the category "balustrades" can be found on page 10. The page references lead you to the required products.



3 Auf den Produktseiten finden Sie Abbildungen und nützliche Zeichnungen. Neben Pflegehinweisen haben wir zusätzlich Verweise auf detaillierte Informationen zum Produkt vermerkt.

Illustrations and useful technical drawings can be found on the product pages. Besides the care instructions you will find additional references to detailed product information.

















































4 In der Rubrik „Bemessungen und Sicherheit“ ab Seite 208 leisten die Informationen wichtige Hilfestellungen bei z. B. Glasdimensionierungen. Außerdem finden Sie Planungsabläufe oder Anwendungsbeispiel – für sicheres Bauen.





The chapter "Design and safety", from page 208 onwards, contains information that provides important assistance for glass dimensioning etc. Furthermore you will find planning processes or application examples for safe building.





■ Systematik und Kombinationsmöglichkeiten | systematics and combination possibilities

| | |  S. p. 16 |  S. p. 52 |  S. p. 58 |  S. p. 46 |  S. p. 141 |  S. p. 147 |
|--|--------------------------|--|--|--|---|---|---|
| Pfosten posts | | | | | | | |
|  | Ø 33,7 x 2,0 | ✓ | ✓ | — | — | ✓ | — |
| | Ø 42,4 x 2,0 | ✓ | ✓ | ✓ | ✓ | ✓ | ✓ |
| | Ø 48,3 x 2,0 | ✓ | ✓ | ✓ | — | — | — |
| | Ø 60,3 x 2,0 | ✓ | ✓ | — | — | — | — |
|  | 30 x 30 x 2,0 | ✓ | ✓ | ✓ | ✓ | ✓ | ✓ |
| | 40 x 40 x 2,0 | ✓ | ✓ | ✓ | ✓ | ✓ | ✓ |
|  | 40 x 20 | ✓ | ✓ | — | — | ✓ | — |
| Füllungen infills | | | | | | | |
|  | VSG = 2 x ESG | ✓  | ✓  | ✓  | ✓  | — | — |
| | VSG = 2 x SPG | ✓  | — | — |  |  | — |
|  | VSG = 2 x TVG | ✓  | ✓  |  |  | — | — |
| | ESG-H | ✓  | — | — | — | — | — |
|  | TRESPA® | ✓  |  |  |  | — | — |
|  | Stäbe bars | — | — | — | — | ✓  | — |
|  | Seile cables | — | — | — | — | ✓  | — |
|  | Lochblech sheet holder | — | — | — | — | — | ✓ |
| Handlauf hand railing | | | | | | | |
|  | Metall metal | ✓ | ✓ | ✓ | ✓ | ✓ | ✓ |
|  | Holz wood | ✓ | ✓ | ✓ | ✓ | ✓ | ✓ |
|  | aufgesteckt plugged on | für Brüstungen nach TRAV Kategorie B ab Seite 236 railings according to TRAV category B on page 236 onward | | | | | |
|  | ohne without |  | ✓  |  |  |  |  |

 o.k.
 möglich auf Anfrage
 possible on request
 nicht möglich | not possible

 Allgemeine bauaufsichtliche Zulassung (AbZ) Z-70.2-28 - Seite 223
 national technical approval (AbZ) Z-70.2-28 - page 223
 Technische Regel für absturzsichernde Verglasung (TRAV) - Seite 236
 technical rules for the use of safety barrier glazing (TRAV) page 236
 Banano mit allgemeinem bauaufsichtlichen Prüfzeugnis - Seite 234
 Banano with an general test certificate from building authorities page 234
 Zustimmung im Einzelfall (ZiE) - Seite 242
 individual approval (ZiE) page 242

 ETB-Nachweis - Seite 232
 ETB proof - page 232
 ETB Nachweis mit Prüfzeugnis für TRESPA®
 Platten - Seite 232
 ETB proof with general test certificate for TRESPA® panels page 232

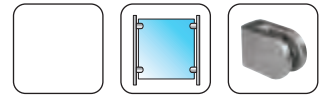

■ Inhalt | content

| | | |
|--|---|--|
| | <ul style="list-style-type: none"> ■ Klemmbefestigungen clamp fixtures 16 Klemmbefestigungen für vorgesetzte Montage 32 clamp fixtures for fascia mounting | |
| | <ul style="list-style-type: none"> Brüstungsverglasung mit cp-mini 46 balustrade glazing with cp-mini | |
| | <ul style="list-style-type: none"> Punkthalter nach TRAV 52 point fixings according to TRAV Punkthaltersystem Banano 58 point-fixed system Banano Zubehör accessories 64 | |

Artikelnummersystem | item number system
17480801 ← Farbe | colour
 ↑ Artikelnummer | item no.





■ Klemmbefestigungen | clamp fixtures

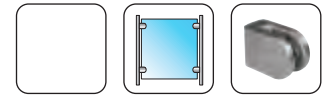

Zinkdruckguss | zinc die cast

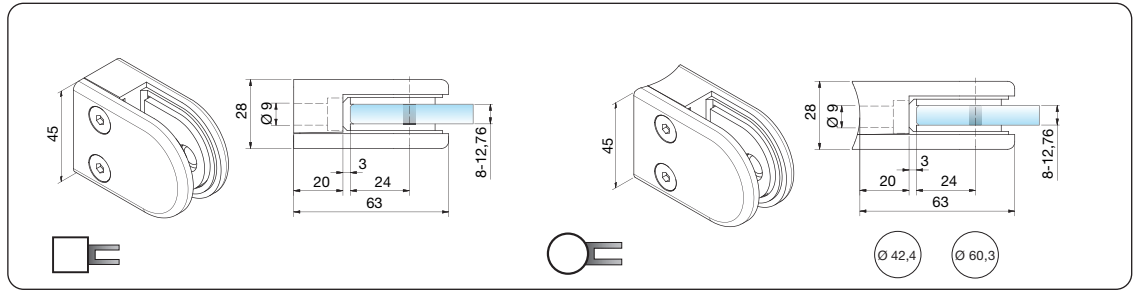

| Art. Nr. item no. | VSG | Mono | Sicherheit safety | | |
|----------------------|----------|-------|----------------------|--|---------|
| 174808__ | 8,76 mm | 8 mm | | | |
| 174809__ | 9,52 mm | | | | |
| 174810__ | 10,76 mm | 10 mm | | | |
| 174811__ | 11,52 mm | | | | |
| 174812__ | 12,76 mm | 12 mm | | | |
| 174842__ | 8,76 mm | 8 mm | | | R20/R30 |
| 174843__ | 9,52 mm | | | | R20/R30 |
| 174852__ | 10,76 mm | 10 mm | | | R20/R30 |
| 174854__ | 11,52 mm | | | | R20/R30 |
| 174853__ | 12,76 mm | 12 mm | | | R20/R30 |

Farbe | colour

| | | | | |
|----|----|----|----|----|
| | | | | |
| 01 | 02 | 03 | 09 | 14 |
| | | | | |
| 04 | 15 | 05 | 06 | 07 |
| | | | | |
| 08 | | | | |

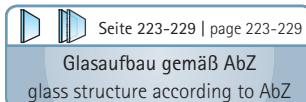

Edelstahl (A4) | stainless steel (A4)

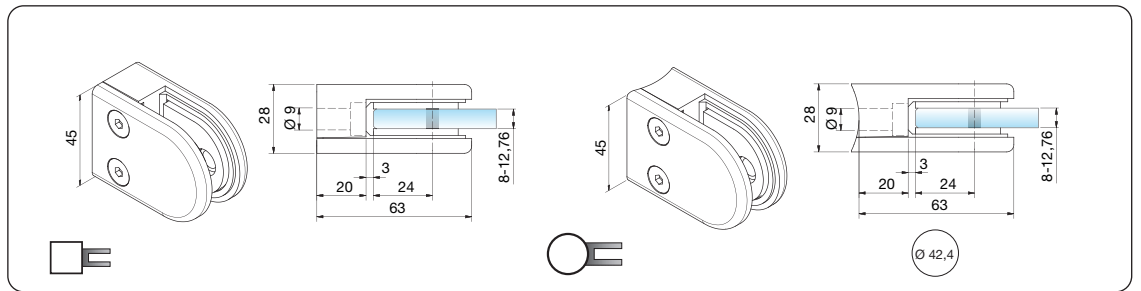

| Art. Nr. item no. | VSG | Mono | Sicherheit safety | | |
|----------------------|----------|-------|----------------------|--|-----|
| 179302__ | 8,76 mm | 8 mm | | | |
| 179300__ | 9,52 mm | | | | |
| 179303__ | 10,76 mm | 10 mm | | | |
| 179301__ | 11,52 mm | | | | |
| 179304__ | 12,76 mm | 12 mm | | | |
| 179306__ | 8,76 mm | 8 mm | | | R22 |
| 179305__ | 9,52 mm | | | | R22 |
| 179307__ | 10,76 mm | 10 mm | | | R22 |
| 179309__ | 11,52 mm | | | | R22 |
| 179308__ | 12,76 mm | 12 mm | | | R22 |

Farbe | colour

| | |
|----|----|
| | |
| 10 | 11 |

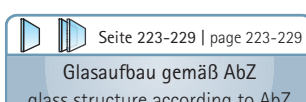

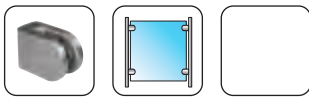

■ Edelstahl (A2) | stainless steel (A2)

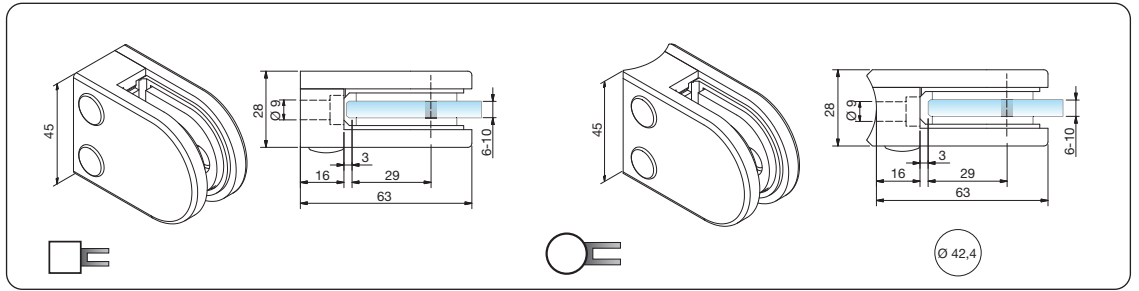

| Art. Nr. item no. | VSG | Mono | |
|----------------------|---------|-------|-----|
| 170001__ | | 6 mm | |
| 170002__ | 6,76 mm | | |
| 170003__ | | 8 mm | |
| 170004__ | 8,76 mm | | |
| 170005__ | 9,52 mm | | |
| 170006__ | | 10 mm | |
| 170007__ | | 6 mm | R21 |
| 170008__ | 6,76 mm | | R21 |
| 170009__ | | 8 mm | R21 |
| 170010__ | 8,76 mm | | R21 |
| 170011__ | 9,52 mm | | R21 |
| 170012__ | | 10 mm | R21 |

Farbe | colour



11

inklusive | included



■ Edelstahl (A2) | stainless steel (A2)

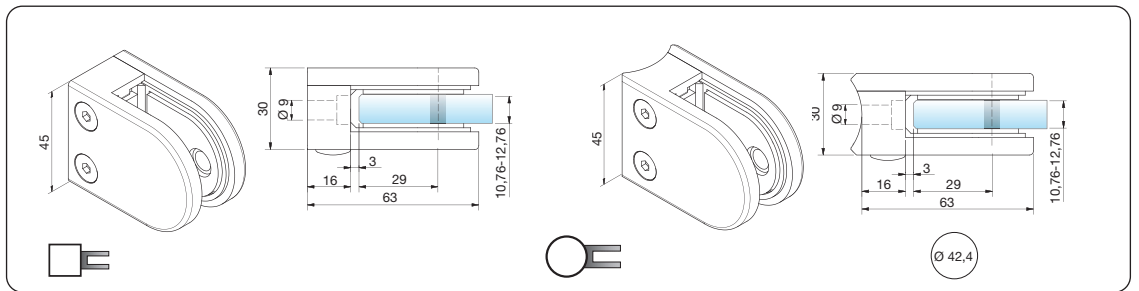

| Art. Nr. item no. | VSG | Mono | |
|----------------------|----------|-------|-----|
| 170013__ | 10,76 mm | | |
| 170014__ | 11,52 mm | | |
| 170015__ | | 12 mm | |
| 170016__ | 12,76 mm | | |
| 170017__ | 10,76 mm | | R21 |
| 170018__ | 11,52 mm | | R21 |
| 170019__ | | 12 mm | R21 |
| 170020__ | 12,76 mm | | R21 |

Farbe | colour



11

inklusive | included



Artikelnummersystem | item number system

17480801 ← Farbe | colour

↑ Artikelnummer | item no.

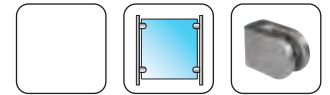

■ Zinkdruckguss | zinc die cast

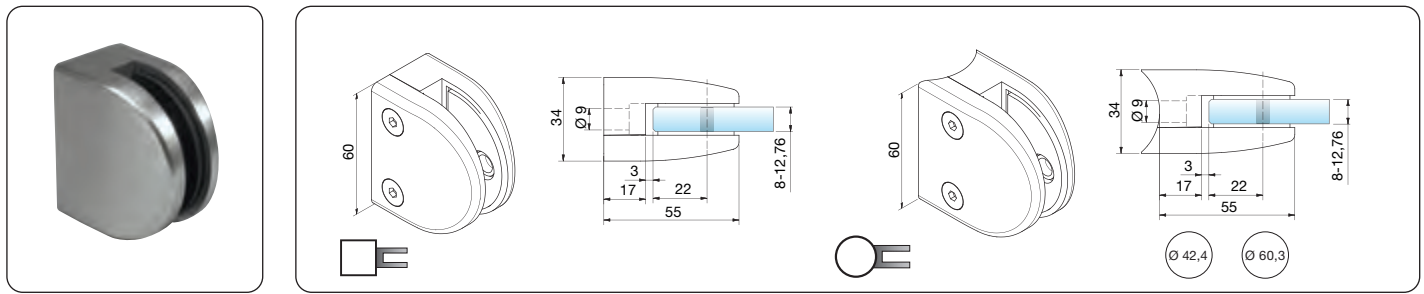

| Art. Nr. item no. | VSG | Mono | Sicherheit safety | auch zugelassen mit also approved with | | |
|----------------------|----------|-------|----------------------|---|--|---------|
| 174813__ | 8,76 mm | 8 mm | | | | |
| 174821__ | 9,52 mm | | | | | |
| 174814__ | 10,76 mm | 10 mm | | | | |
| 179013__ | 11,52 mm | | | | | |
| 179014__ | 12,76 mm | 12 mm | | | | |
| 174816__ | 8,76 mm | 8 mm | | | | R22/R30 |
| 174827__ | 9,52 mm | | | | | R22/R30 |
| 174817__ | 10,76 mm | 10 mm | | | | R22/R30 |
| 179016__ | 11,52 mm | | | | | R22/R30 |
| 179017__ | 12,76 mm | 12 mm | | | | R22/R30 |

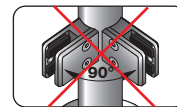
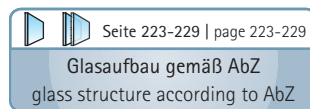
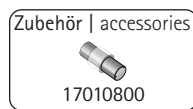
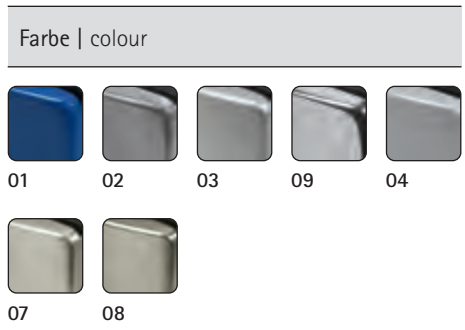

■ Edelstahl (A4) | stainless steel (A4)

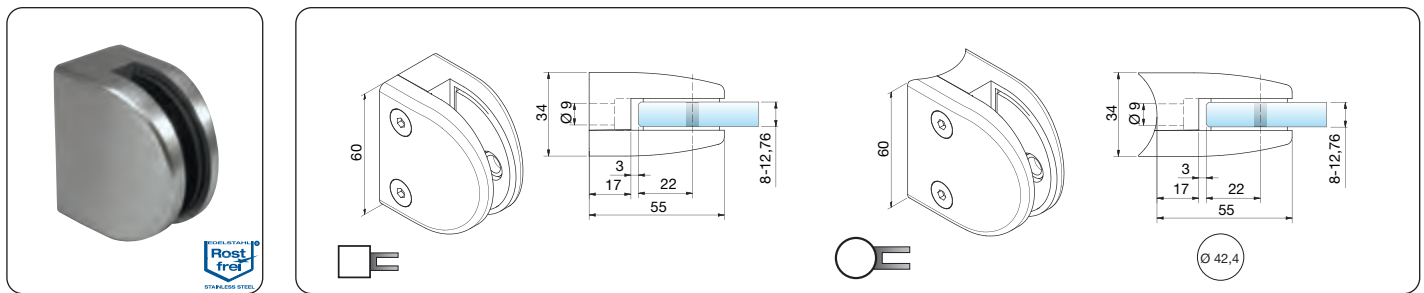

| Art. Nr. item no. | VSG | Mono | Sicherheit safety | auch zugelassen mit also approved with | | |
|----------------------|----------|-------|----------------------|---|--|-----|
| 179322__ | 8,76 mm | 8 mm | | | | |
| 179320__ | 9,52 mm | | | | | |
| 179323__ | 10,76 mm | 10 mm | | | | |
| 179321__ | 11,52 mm | | | | | |
| 179324__ | 12,76 mm | 12 mm | | | | |
| 179326__ | 8,76 mm | 8 mm | | | | R22 |
| 179325__ | 9,52 mm | | | | | R22 |
| 179327__ | 10,76 mm | 10 mm | | | | R22 |
| 179329__ | 11,52 mm | | | | | R22 |
| 179328__ | 12,76 mm | 12 mm | | | | R22 |

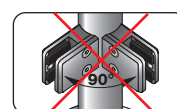
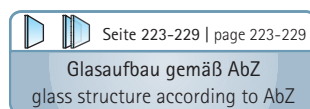
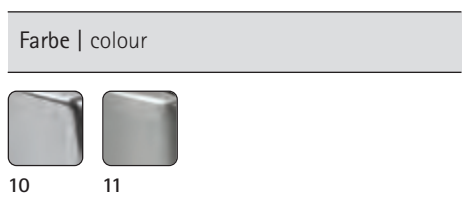



■ Zinkdruckguss | zinc die cast

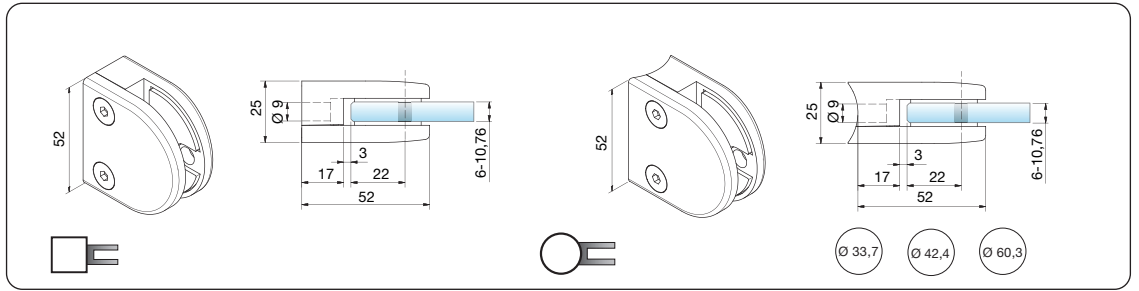

| Art. Nr. item no. | VSG | Mono | Sicherheit safety | | |
|----------------------|----------|-------|----------------------|--|-------------|
| 170021__ | 6,76 mm | 6 mm | | | |
| 170022__ | 9,52 mm | | | | |
| 170023__ | 8,76 mm | 8 mm | | | |
| 170024__ | 10,76 mm | 10 mm | | | |
| 170025__ | 6,76 mm | 6 mm | | | R15/R20/R27 |
| 170026__ | 8,76 mm | 8 mm | | | R15/R20/R27 |
| 170027__ | 9,52 mm | | | | R15/R20/R27 |
| 170028__ | 10,76 mm | 10 mm | | | R15/R20/R27 |

Farbe | colour



Zubehör | accessories



17010600



Seite 223-229 | page 223-229

Glasaufbau gemäß AbZ
glass structure according to AbZ

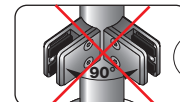

R15

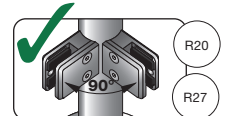

R20

R27

■ INFO



Pflegeprodukte Seite
treatment products 608-615
Pflegeinfo Seite | treatment
instructions 621-622



10

11

Abbrutschsicherung durch Sicherungsstift | locking pin slip protection

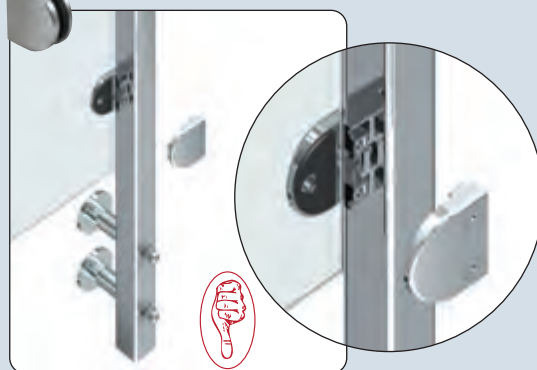

Der Einsatz des Sicherungsstiftes gewährleistet die bei vorge-
setzten Montagen vorgeschriebene mechanische Sicherung
gegen das Abrutschen der Scheibe.
Weitere Details und eine Auflistung entsprechend zugelassener
Klemmen finden Sie auf Seite 226.

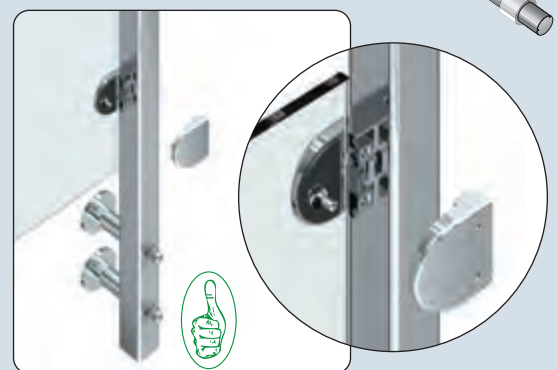

The use of the locking pin provides the prescribed level
of mechanical protection needed to ensure that the fascia-
mounted glass panel does not slip.
For further details and a list of approved clamps,
please see page 226.



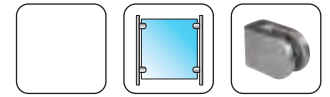

■ Zinkdruckguss | zinc die cast

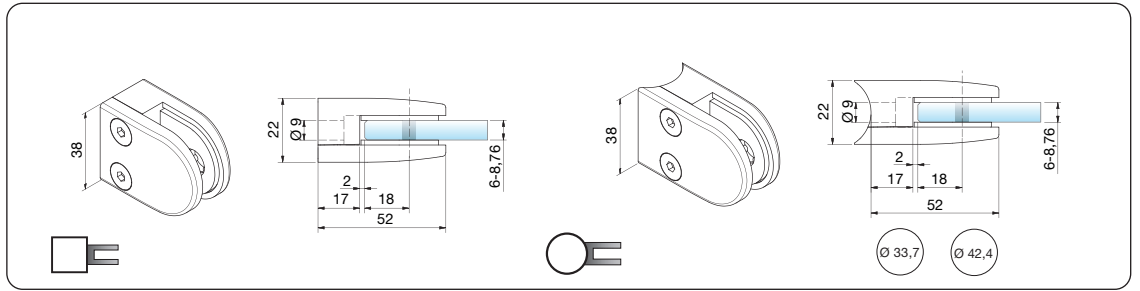
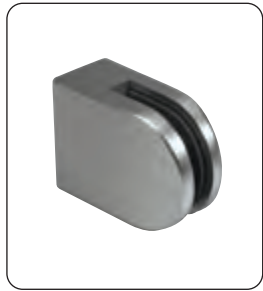

| Art. Nr. item no. | VSG | Mono | Sicherheit safety |
|----------------------|---------|------|----------------------|
| 174819__ | 6,76 mm | 6 mm | |
| 174818__ | 8,76 mm | 8 mm | |
| 174823__ | 6,76 mm | 6 mm | |
| 174822__ | 8,76 mm | 8 mm | |

Farbe | colour

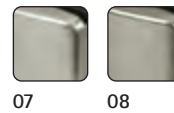

Zubehör | accessories

17010400

Seite 223-229 | page 223-229
Glasaufbau gemäß AbZ
glass structure according to AbZ

■ Edelstahl (A4) | stainless steel (A4)

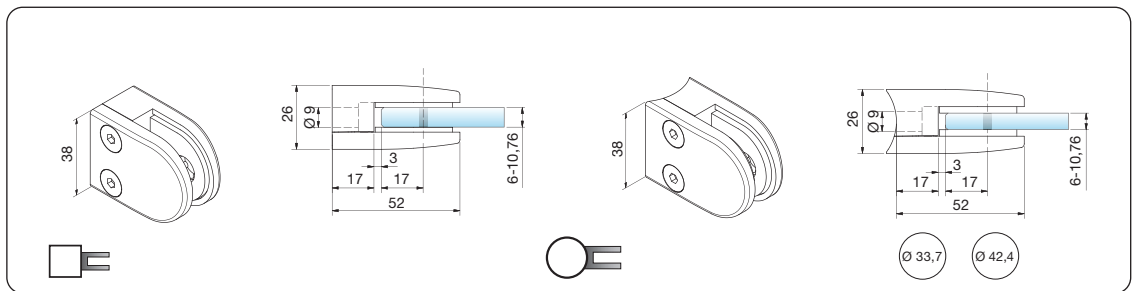

| Art. Nr. item no. | VSG | Mono | |
|----------------------|----------|-------|--|
| 179312__ | 6,76 mm | 6 mm | |
| 179313__ | 8,76 mm | 8 mm | |
| 179314__ | 10,76 mm | 10 mm | |
| 179316__ | 6,76 mm | 6 mm | |
| 179317__ | 8,76 mm | 8 mm | |
| 179318__ | 10,76 mm | 10 mm | |

Farbe | colour



Zubehör | accessories

17010800

Seite 223-229 | page 223-229
Glasaufbau gemäß AbZ
glass structure according to AbZ





■ Edelstahl (A2) | stainless steel (A2)

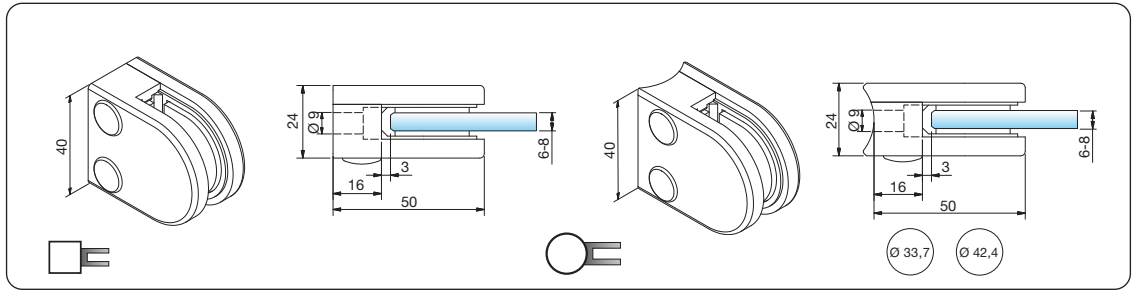

| Art. Nr. item no. | VSG | Mono | |
|----------------------|---------|------|--|
| 170029__ | | 6 mm | |
| 170030__ | 6,76 mm | | |
| 170031__ | | 8 mm | |
| 170032__ | | 6 mm | |
| 170033__ | 6,76 mm | | |
| 170034__ | | 8 mm | |
| 170035__ | | 6 mm | |
| 170036__ | 6,76 mm | | |
| 170037__ | | 8 mm | |

Farbe | colour



11

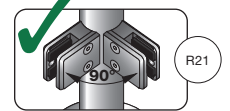
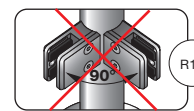

■ INFO



Der Einsatz des Sicherungsstiftes gewährleistet die bei vorge-
setzten Montagen vorgeschriebene mechanische Sicherung
gegen das Abrutschen der Scheibe.
Weitere Details und eine Auflistung entsprechend zugelassener
Klemmen finden Sie auf Seite 226.

The use of the locking pin provides the prescribed level
of mechanical protection needed to ensure that the fascia-
mounted glass panel does not slip.
For further details and a list of approved clamps,
please see page 226.

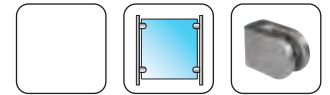

■ Zinkdruckguss | zinc die cast

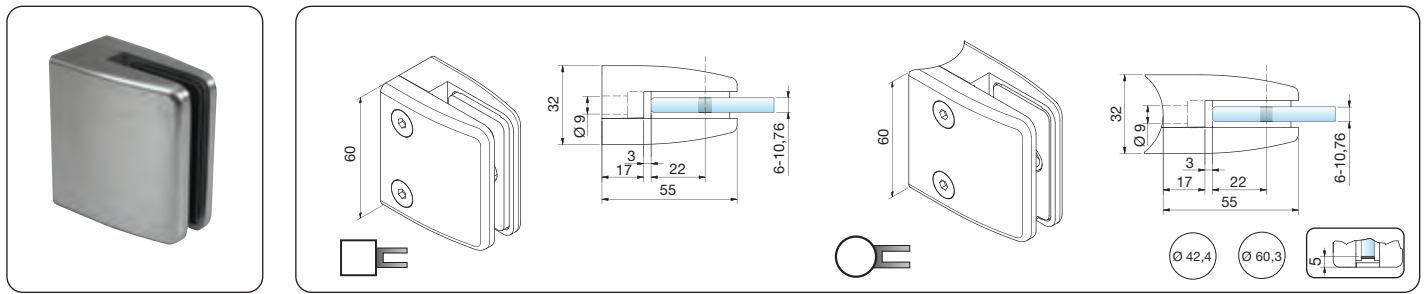

| Art. Nr. item no. | VSG | Mono | Sicherheit safety | auch zugelassen mit also approved with |
|----------------------|----------|-------|----------------------|---|
| 179001__ | 6,76 mm | 6 mm | | |
| 174804__ | 8,76 mm | 8 mm | | |
| 179002__ | 9,52 mm | | | |
| 174805__ | 10,76 mm | 10 mm | | |
| 179005__ | 6,76 mm | 6 mm | | R20/R33 |
| 174806__ | 8,76 mm | 8 mm | | |
| 179006__ | 9,52 mm | | | R20/R33 |
| 174807__ | 10,76 mm | 10 mm | | |

Farbe | colour

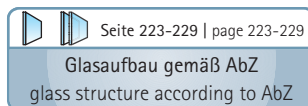
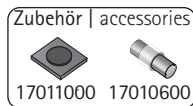
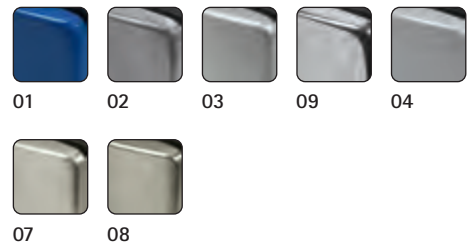

■ Edelstahl (A4) | stainless steel (A4)

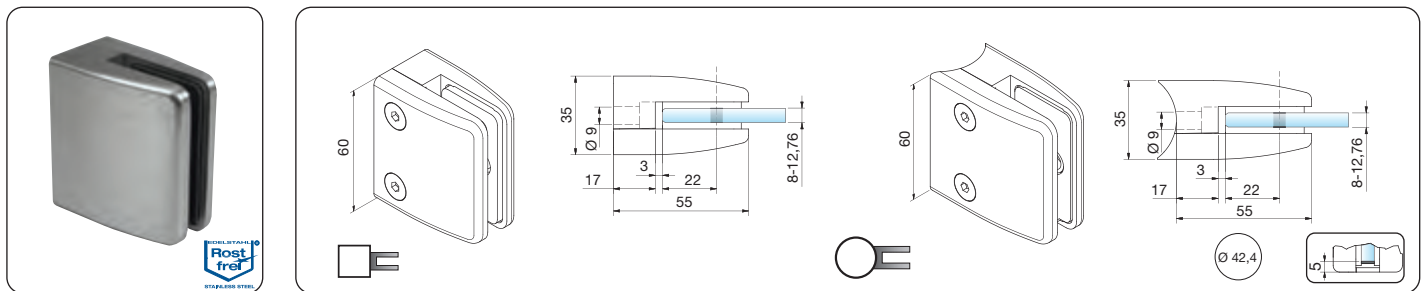

| Art. Nr. item no. | VSG | Mono | Sicherheit safety | auch zugelassen mit also approved with |
|----------------------|----------|-------|----------------------|---|
| 179332__ | 8,76 mm | 8 mm | | |
| 179330__ | 9,52 mm | | | |
| 179333__ | 10,76 mm | 10 mm | | |
| 179331__ | 11,52 mm | | | |
| 179334__ | 12,76 mm | 12 mm | | |
| 179336__ | 8,76 mm | 8 mm | | R22 |
| 179335__ | 9,52 mm | | | R22 |
| 179337__ | 10,76 mm | 10 mm | | R22 |
| 179339__ | 11,52 mm | | | R22 |
| 179338__ | 12,76 mm | 12 mm | | R22 |

Farbe | colour

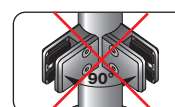
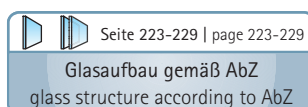
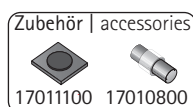
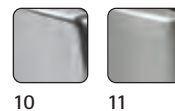



■ Edelstahl (A2) | stainless steel (A2)

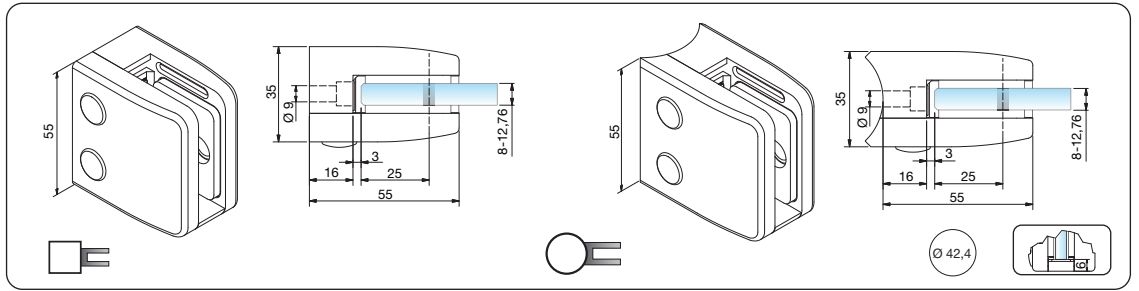

| Art. Nr. item no. | VSG | Mono | □ | ○ |
|----------------------|----------|-------|---|-----|
| 170038__ | | 8 mm | □ | |
| 170039__ | 8,76 mm | | □ | |
| 170040__ | 9,52 mm | | □ | |
| 170041__ | | 10 mm | □ | |
| 170042__ | 10,76 mm | | □ | |
| 170043__ | 11,52 mm | | □ | |
| 170044__ | | 12 mm | □ | |
| 170045__ | 12,76 mm | | □ | |
| 170046__ | | 8 mm | ○ | R21 |
| 170047__ | 8,76 mm | | ○ | R21 |
| 170048__ | 9,52 mm | | ○ | R21 |
| 170049__ | | 10 mm | ○ | R21 |
| 170050__ | 10,76 mm | | ○ | R21 |
| 170051__ | 11,52 mm | | ○ | R21 |
| 170052__ | | 12 mm | ○ | R21 |
| 170053__ | 12,76 mm | | ○ | R21 |

Farbe | colour



11

inklusive | included



■ INFO

Abrutschsicherung durch Sicherungsplatte | locking plate slip protection



Pflegeprodukte Seite
treatment products 608-615
Pflegeinfo Seite | treatment
instructions 621-622



10 11

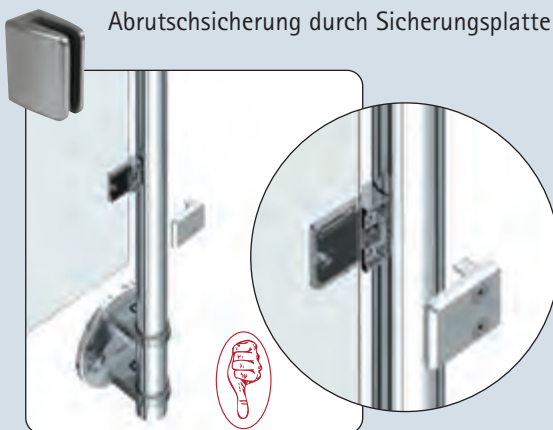

Der Einsatz der Sicherungsplatte gewährleistet die bei vorge-
setzten Montagen vorgeschriebene mechanische Sicherung
gegen das Abrutschen der Scheibe. Weitere Details und eine
Auflistung entsprechend zugelassener Klemmen finden Sie auf
Seite 228.

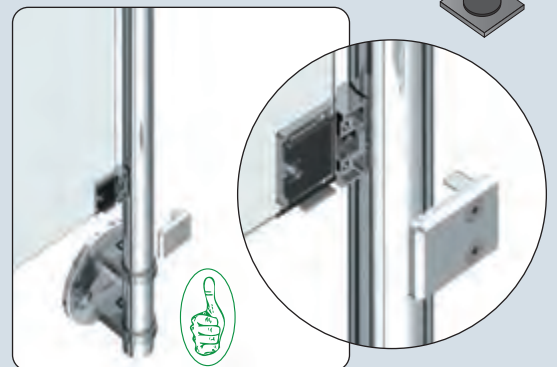

The use of the locking plate provides the prescribed level
of mechanical protection needed to ensure that the fascia-
mounted glass panel does not slip.
For further details and a list of approved clamps,
please see page 228.

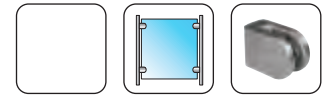

Zinkdruckguss | zinc die cast

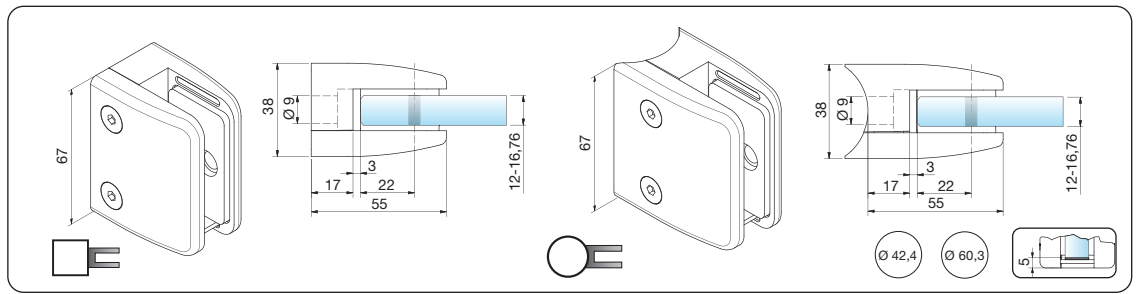
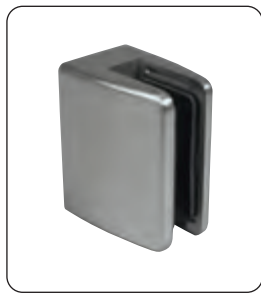

| Art. Nr. item no. | VSG | Mono | Sicherheit safety | auch zugelassen mit also approved with |
|----------------------|----------|-------|----------------------|---|
| 174891__ | 12,76 mm | 12 mm | | |
| 174890__ | 13,52 mm | | | |
| 174892__ | | 14 mm | | |
| 179082__ | | 15 mm | | |
| 174893__ | 16,76 mm | | | |
| 174894__ | 12,76 mm | 12 mm | | |
| 174897__ | 13,52 mm | | | |
| 174895__ | | 14 mm | | |
| 179086__ | | 15 mm | | |
| 174896__ | 16,76 mm | | | |

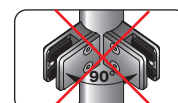
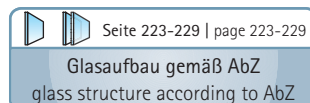
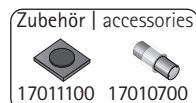
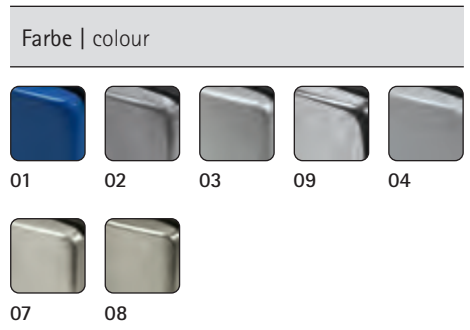

Zinkdruckguss | zinc die cast

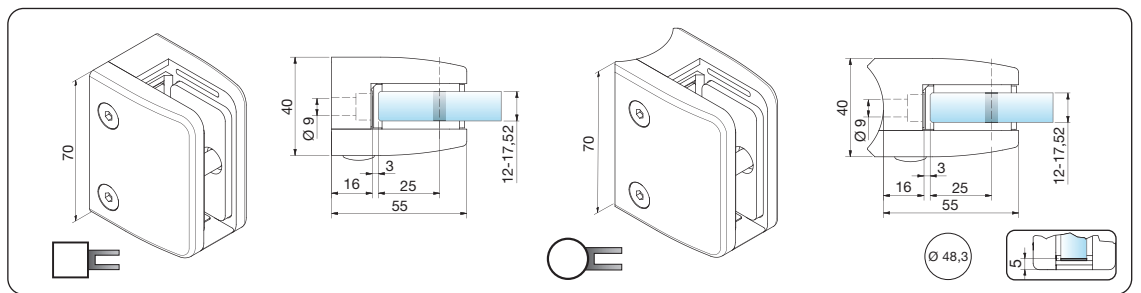

| Art. Nr. item no. | VSG | Mono | | |
|----------------------|----------|-------|--|-----|
| 179090__ | | 12 mm | | |
| 179091__ | 12,76 mm | | | |
| 179092__ | | 16 mm | | |
| 179093__ | 16,76 mm | | | |
| 179094__ | 17,52 mm | | | |
| 179095__ | | 12 mm | | R24 |
| 179096__ | 12,76 mm | | | R24 |
| 179097__ | | 16 mm | | R24 |
| 179098__ | 16,76 mm | | | R24 |
| 179099__ | 17,52 mm | | | R24 |

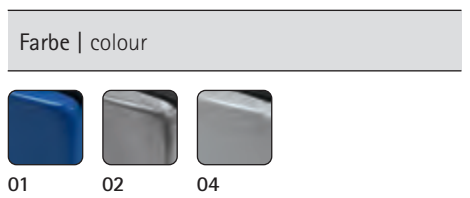



Edelstahl (A4) | stainless steel (A4)

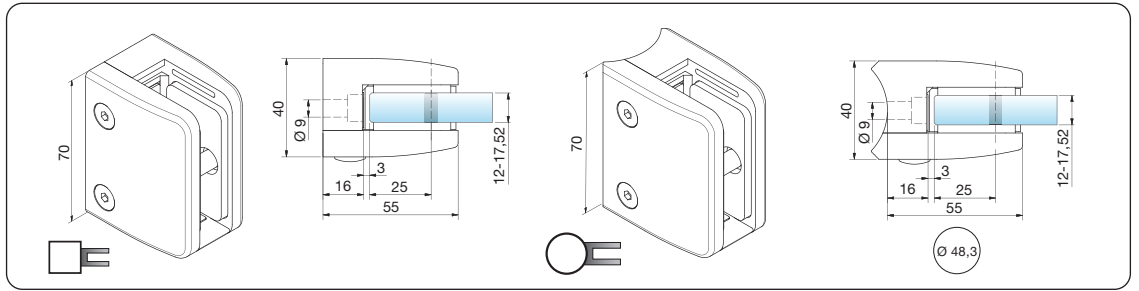

| Art. Nr. item no. | VSG | Mono | □ | ○ |
|----------------------|----------|-------|---|-----|
| 179390__ | | 12 mm | □ | ○ |
| 179391__ | 12,76 mm | | □ | ○ |
| 179392__ | | 16 mm | □ | ○ |
| 179393__ | 16,76 mm | | □ | ○ |
| 179394__ | 17,52 mm | | □ | ○ |
| 179395__ | | 12 mm | ○ | R24 |
| 179396__ | 12,76 mm | | ○ | R24 |
| 179397__ | | 16 mm | ○ | R24 |
| 179398__ | 16,76 mm | | ○ | R24 |
| 179399__ | 17,52 mm | | ○ | R24 |

Farbe | colour



11

inklusive | included



INFO



10 11

Abrutschsicherung durch Sicherungsplatte | locking plate slip protection

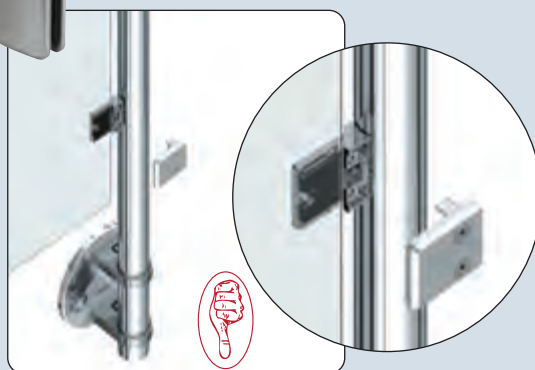

Der Einsatz der Sicherungsplatte gewährleistet die bei vorge-setzten Montagen vorgeschriebene mechanische Sicherung gegen das Abrutschen der Scheibe. Weitere Details und eine Auflistung entsprechend zugelassener Klemmen finden Sie auf Seite 228.

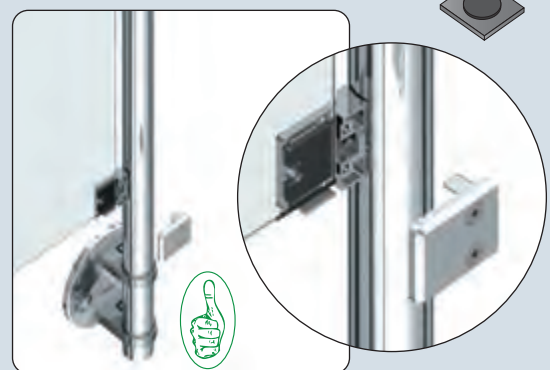

The use of the locking plate provides the prescribed level of mechanical protection needed to ensure that the fascia-mounted glass panel does not slip. For further details and a list of approved clamps, please see page 228.

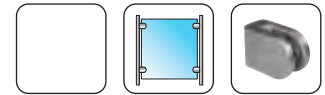

■ Zinkdruckguss | zinc die cast

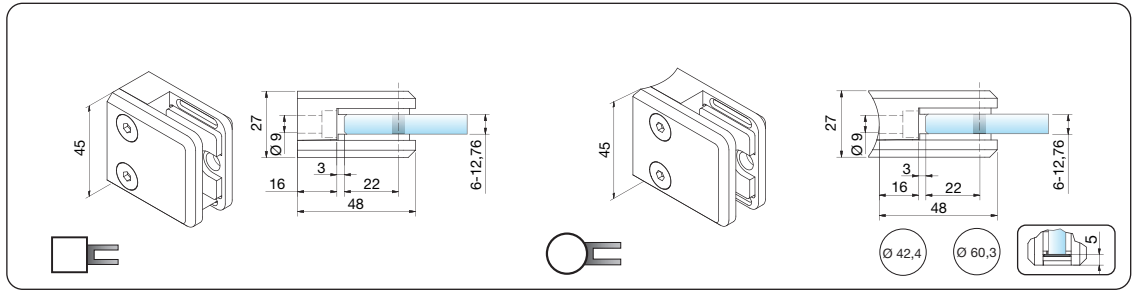

| Art. Nr. item no. | VSG | Mono | Sicherheit safety | auch zugelassen mit also approved with |
|----------------------|----------|-------|----------------------|---|
| 174844__ | 6,76 mm | 6 mm | | |
| 174845__ | 8,76 mm | 8 mm | | |
| 174841__ | 9,52 mm | | | |
| 174846__ | 10,76 mm | 10 mm | | |
| 179044__ | 11,52 mm | | | |
| 179045__ | 12,76 mm | 12 mm | | |
| 174851__ | 6,76 mm | 6 mm | | R22/R30 |
| 174847__ | 8,76 mm | 8 mm | | R22/R30 |
| 174859__ | 9,52 mm | | | R22/R30 |
| 174848__ | 10,76 mm | 10 mm | | R22/R30 |
| 179047__ | 11,52 mm | | | R22/R30 |
| 179048__ | 12,76 mm | 12 mm | | R22/R30 |

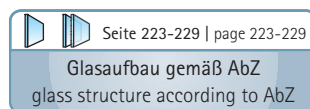
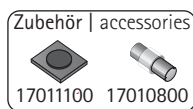
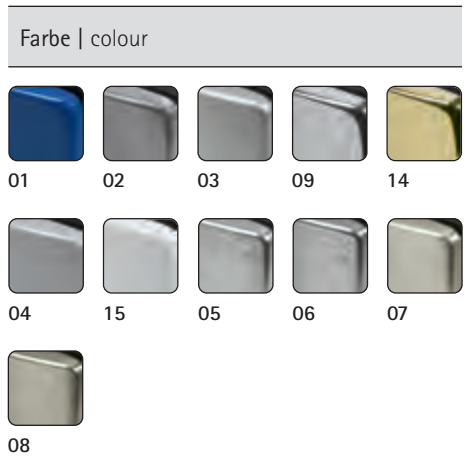

■ INFO

Abrutschsicherung durch Sicherungsplatte | locking plate slip protection

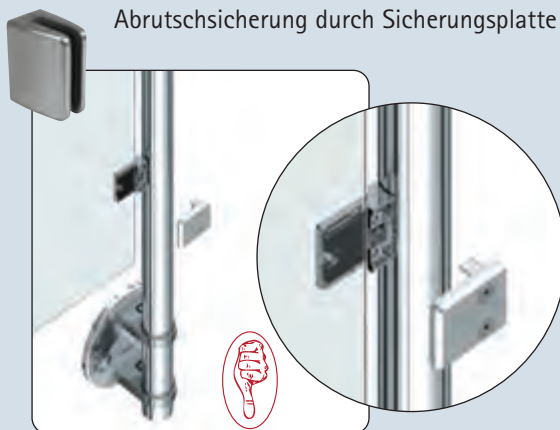

Der Einsatz der Sicherungsplatte gewährleistet die bei vorge-
setzten Montagen vorgeschriebene mechanische Sicherung
gegen das Abrutschen der Scheibe. Weitere Details und eine
Auflistung entsprechend zugelassener Klemmen finden Sie auf
Seite 228.

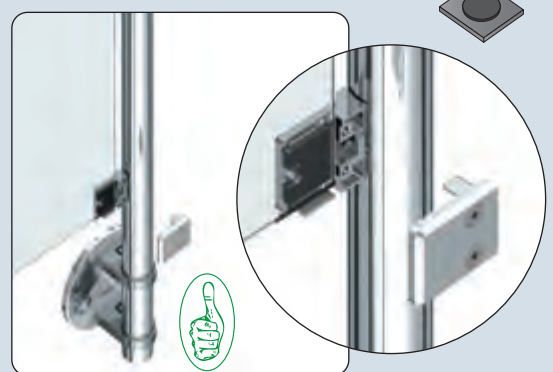

The use of the locking plate provides the prescribed level
of mechanical protection needed to ensure that the fascia-
mounted glass panel does not slip.
For further details and a list of approved clamps,
please see page 228.



■ Edelstahl (A4) | stainless steel (A4)

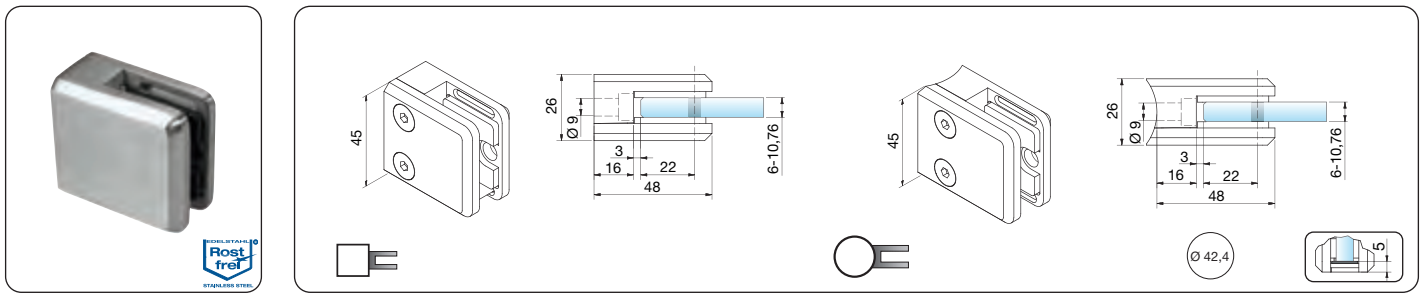

| Art. Nr. item no. | VSG | Mono | Sicherheit safety | auch zugelassen mit also approved with |
|----------------------|----------|-------|----------------------|---|
| 179342__ | 6,76 mm | 6 mm | | |
| 179343__ | 8,76 mm | 8 mm | | |
| 179341__ | 9,52 mm | | | |
| 179344__ | 10,76 mm | 10 mm | | |
| 179346__ | 6,76 mm | 6 mm | | R22 |
| 179347__ | 8,76 mm | 8 mm | | R22 |
| 179349__ | 9,52 mm | | | R22 |
| 179348__ | 10,76 mm | 10 mm | | R22 |

Farbe | colour

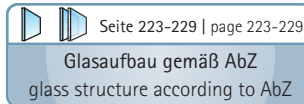
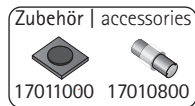
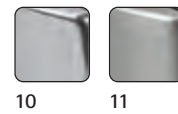

■ Klemmen aus Edelstahl (A2) | stainless steel clamps (A2)

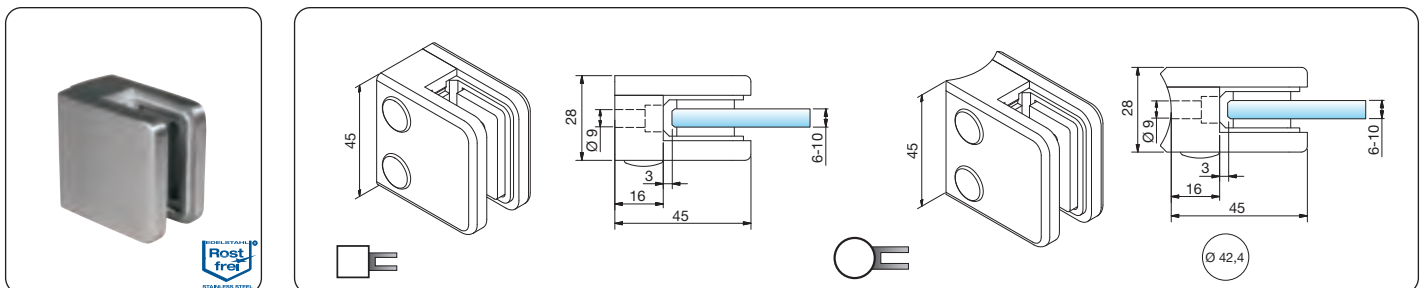

| Art. Nr. item no. | VSG | Mono | | |
|----------------------|---------|-------|--|-----|
| 170054__ | | 6 mm | | |
| 170055__ | 6,76 mm | | | |
| 170056__ | | 8 mm | | |
| 170057__ | 8,76 mm | | | |
| 170058__ | 9,52 mm | | | |
| 170059__ | | 10 mm | | |
| 170060__ | | 6 mm | | R21 |
| 170061__ | 6,76 mm | | | R21 |
| 170062__ | | 8 mm | | R21 |
| 170063__ | 8,76 mm | | | R21 |
| 170064__ | 9,52 mm | | | R21 |
| 170065__ | | 10 mm | | R21 |

Farbe | colour



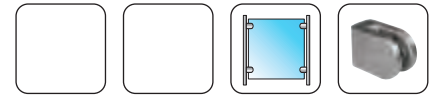

Zinkdruckguss | zinc die cast

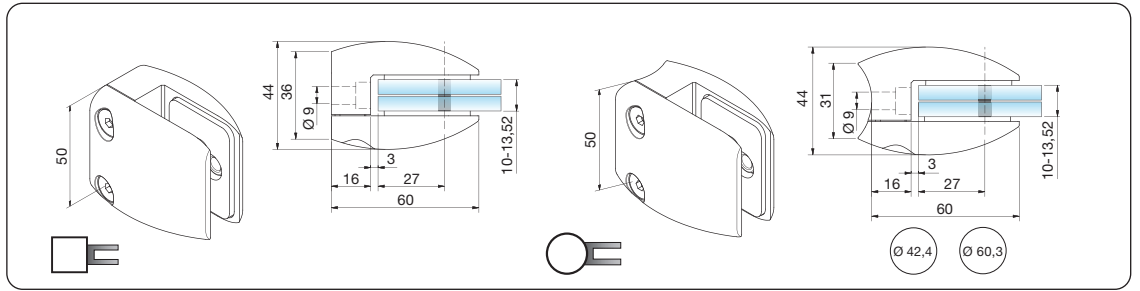

| Art. Nr. item no. | VSG | Mono | Sicherheit safety | |
|----------------------|----------|-------|----------------------|-----------|
| 179032__ | 8,76 mm | | | ☐ |
| 179032__ | 9,52 mm | | | ☐ |
| 174831__ | 10,76 mm | | AbZ | ☐ |
| 174831__ | 11,52 mm | | AbZ | ☐ |
| 174834__ | | 10 mm | | ☐ |
| 174832__ | 12,76 mm | | AbZ | ☐ |
| 174832__ | 13,52 mm | | AbZ | ☐ |
| 174835__ | | 12 mm | | ☐ |
| 179036__ | 8,76 mm | | | ○ R22/R30 |
| 179036__ | 9,52 mm | | | ○ R22/R30 |
| 174836__ | 10,76 mm | | AbZ | ○ R22/R30 |
| 174836__ | 11,52 mm | | AbZ | ○ R22/R30 |
| 174838__ | | 10 mm | | ○ R22/R30 |
| 174837__ | 12,76 mm | | AbZ | ○ R22/R30 |
| 174837__ | 13,52 mm | | AbZ | ○ R22/R30 |
| 174839__ | | 12 mm | | ○ R22/R30 |

Farbe | colour

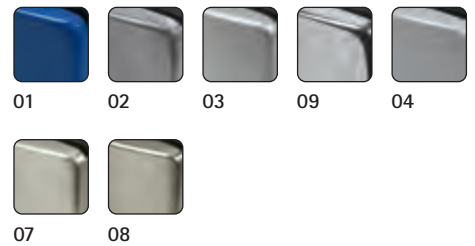

Zubehör | accessories



17010500

Seite 223-229 | page 223-229

Glasaufbau gemäß AbZ
glass structure according to AbZ

INFO

Abrutschsicherung durch Sicherungsstift | locking pin slip protection



Der Einsatz des Sicherungsstiftes gewährleistet die bei vorge-setzten Montagen vorgeschriebene mechanische Sicherung gegen das Abrutschen der Scheibe. Weitere Details und eine Auflistung entsprechend zugelassener Klemmen finden Sie auf Seite 226.

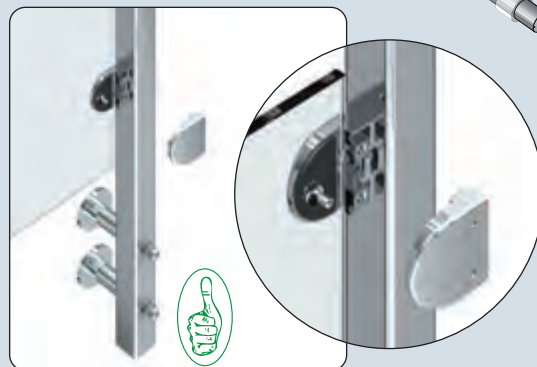

The use of the locking pin provides the prescribed level of mechanical protection needed to ensure that the fascia-mounted glass panel does not slip. For further details and a list of approved clamps, please see page 226.

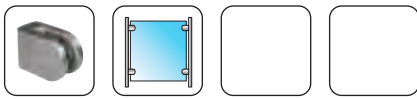

■ Zinkdruckguss | zinc die cast

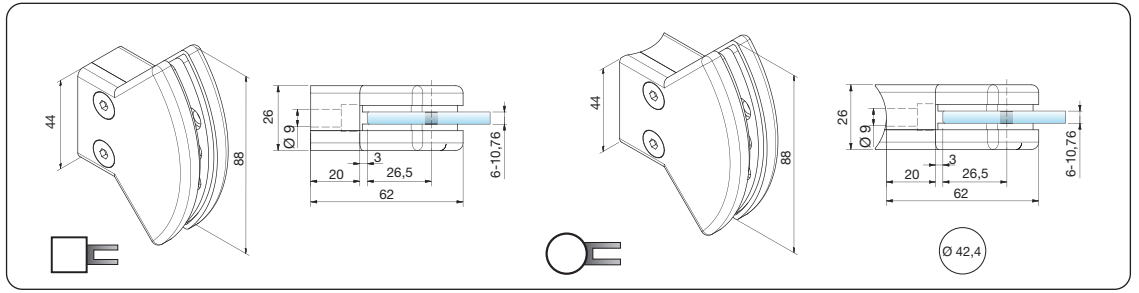

| Art. Nr. item no. | VSG | Mono | Sicherheit safety | auch zugelassen mit also approved with |
|----------------------|----------|-------|----------------------|---|
| 179520__ | 6,76 mm | 6 mm | | |
| 179521__ | 8,76 mm | 8 mm | | |
| 179523__ | 9,52 mm | | | |
| 179522__ | 10,76 mm | 10 mm | | |
| 179720__ | 6,76 mm | 6 mm | | R20 |
| 179721__ | 8,76 mm | 8 mm | | R20 |
| 179723__ | 9,52 mm | | | R20 |
| 179722__ | 10,76 mm | 10 mm | | R20 |

Farbe | colour

01 02 03 09 07

08



Zubehör | accessories

17010600

Seite 223-229 | page 223-229

Glasaufbau gemäß AbZ
glass structure according to AbZ

■ Zinkdruckguss | zinc die cast

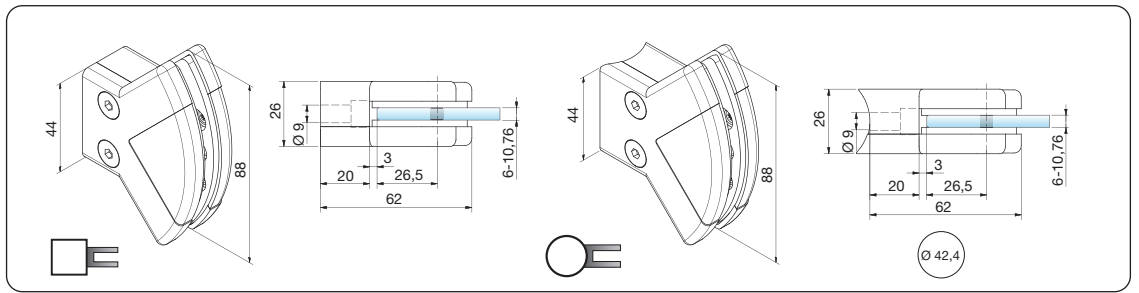

| Art. Nr. item no. | VSG | Mono | Sicherheit safety | auch zugelassen mit also approved with |
|----------------------|----------|-------|----------------------|---|
| 179510__ | 6,76 mm | 6 mm | | |
| 179511__ | 8,76 mm | 8 mm | | |
| 179513__ | 9,52 mm | | | |
| 179512__ | 10,76 mm | 10 mm | | |
| 179710__ | 6,76 mm | 6 mm | | R20 |
| 179711__ | 8,76 mm | 8 mm | | R20 |
| 179713__ | 9,52 mm | | | R20 |
| 179712__ | 10,76 mm | 10 mm | | R20 |

Farbe | colour

12 13



Zubehör | accessories

17010600









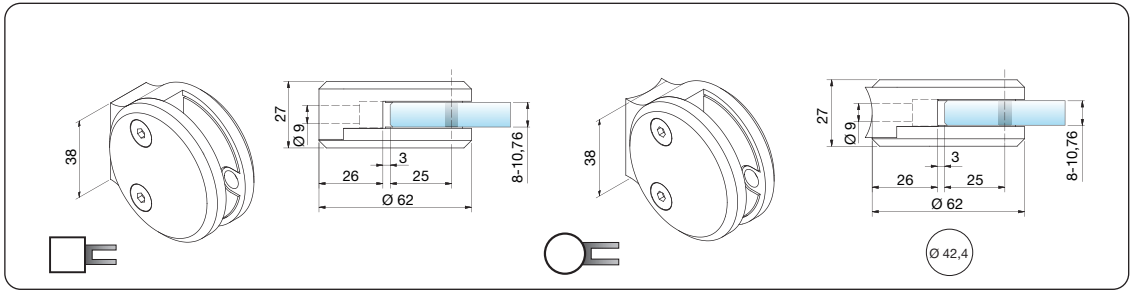



Seite 223-229 | page 223-229

Glasaufbau gemäß AbZ
glass structure according to AbZ



Zinkdruckguss | zinc die cast



| Art. Nr. item no. | VSG  | Mono  | Sicherheit safety  |   |
|----------------------|---|--|--|---|
| 174855__ | 8,76 mm | 8 mm |  |  |
| 174856__ | 10,76 mm | 10 mm |  |  |
| 174857__ | 8,76 mm | 8 mm |  |  R20 |
| 174858__ | 10,76 mm | 10 mm |  |  R20 |

Farbe | colour

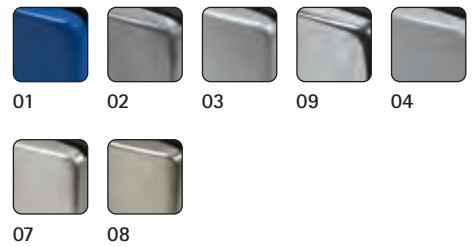

Zubehör | accessories



17010600





■ Spezialklemmbefestigungen aus Zinkdruckguss | special clamp fixtures in zinc die cast

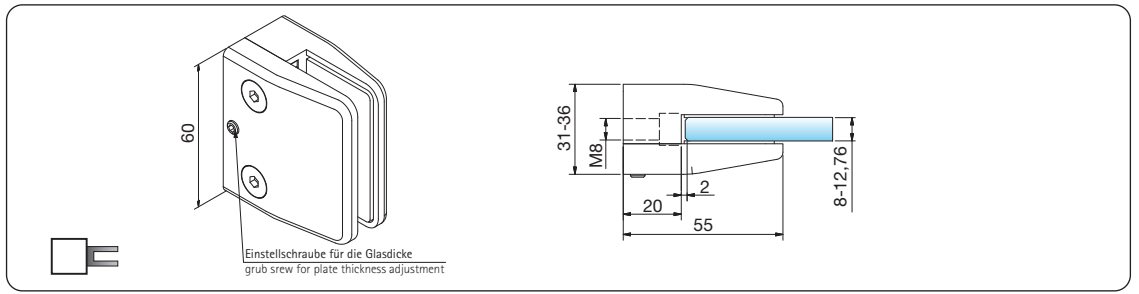

| Art. Nr. item no. | VSG | Mono | | |
|----------------------|-----------------|-----------|--|--|
| 174803__ | 8,76 - 12,76 mm | 8 - 12 mm | | |

| Farbe colour | | | | |
|----------------|----|----|----|----|
| | | | | |
| 01 | 02 | 03 | 09 | 04 |
| | | | | |
| 07 | 08 | | | |

■ Spezialklemmbefestigungen aus Zinkdruckguss | special clamp fixtures in zinc die cast

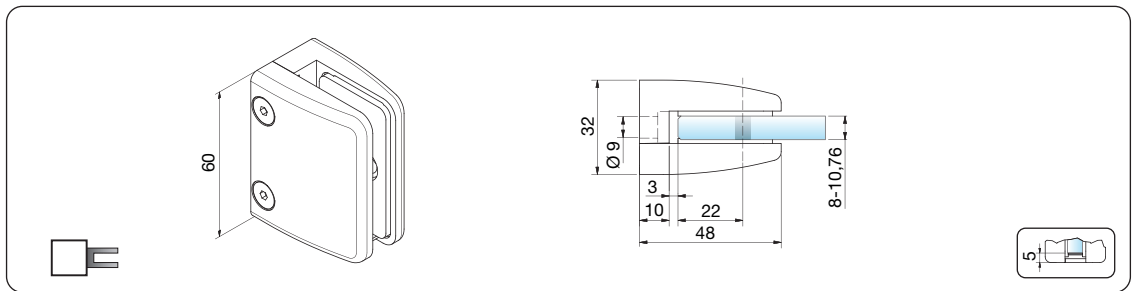

| Art. Nr. item no. | VSG | Mono | Sicherheit safety | auch zugelassen mit also approved with | |
|----------------------|----------|-------|----------------------|---|--|
| 174801__ | 8,76 mm | 8 mm | | | |
| 174800__ | 9,52 mm | | | | |
| 174802__ | 10,76 mm | 10 mm | | | |

| Farbe colour | | | | |
|----------------|----|----|----|----|
| | | | | |
| 01 | 02 | 03 | 09 | 04 |
| | | | | |
| 07 | 08 | | | |

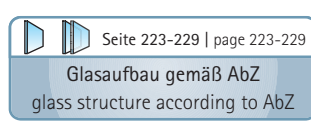
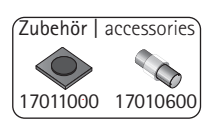

■ INFO Geringer Wandabstand | small wall clearance

4801

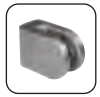
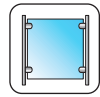

■ Inhalt | content

- Klemmbefestigungen für vorgesetzte Montage 32-45
clamp fixtures for fascia mounting

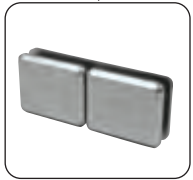

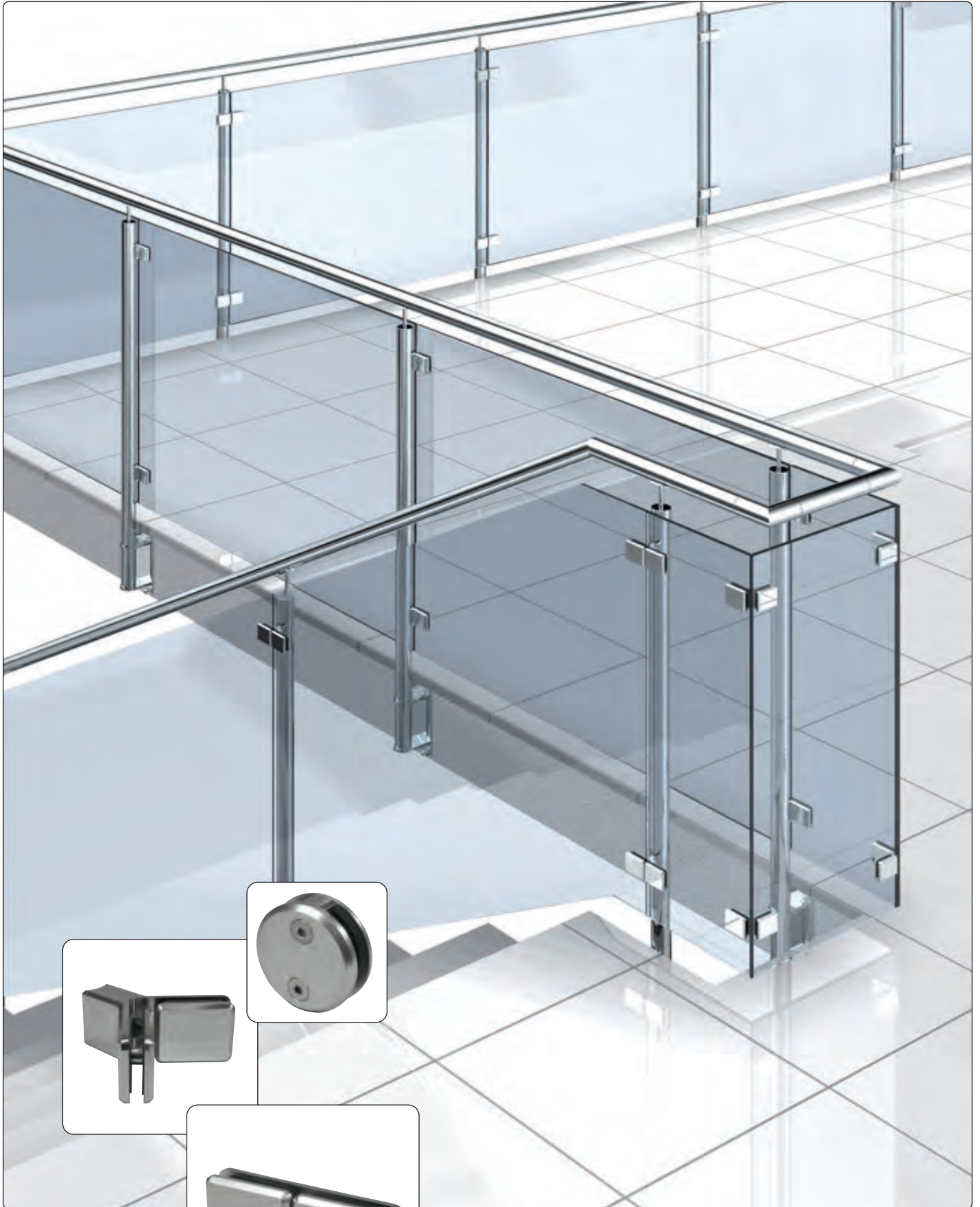

■ Klemmbefestigungen für vorgesetzte Montage
clamp fixtures for fascia mounting

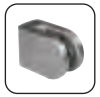
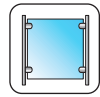

■ Systematik | systematics

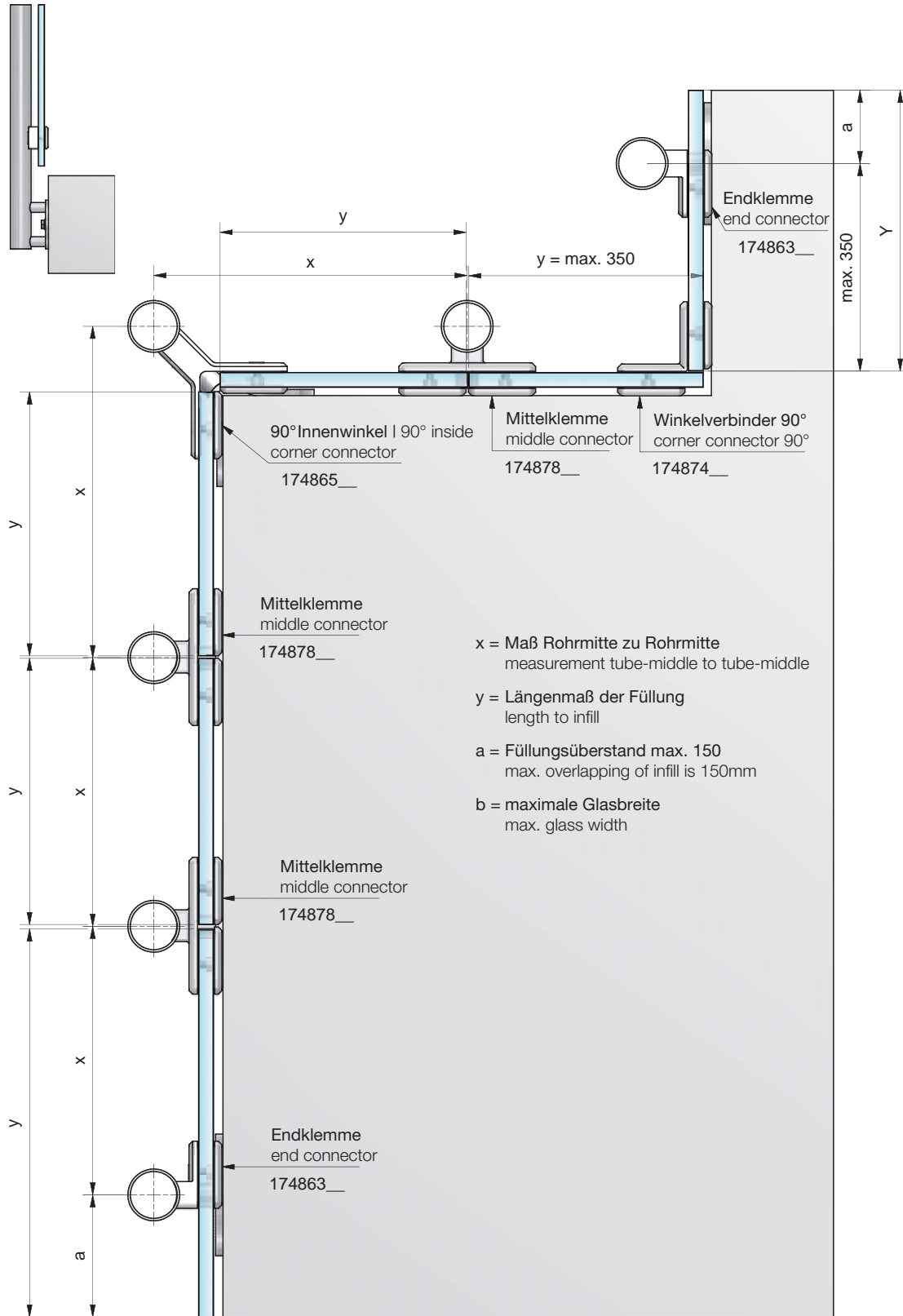



■ Berechnung der Glasmaße | determination of the glass measurement

| Art. Nr. | Anwendung application | Glasstärke glass thickness | Ø 38,4 | Ø 40 | Ø 42,4 | Ø 48,3 | Ø 50 | Ø 60 |
|-------------------|-------------------------|------------------------------|-------------------|-------------------|-------------------|-------------------|-------------------|-------------------|
| 174878__-174863__ | | 8-10-12 | -1 | -1 | -1 | -1 | -1 | -1 |
| 174878__-174878__ | | 8-10-12 | -2 | -2 | -2 | -2 | -2 | -2 |
| 174865__-174878__ | | 8-10 | -52 | -53 | -54,5 | -57 | -52 | -55,5 |
| 174863__-174865__ | | 8-10 | -52 | -53 | -54,5 | -57 | -52 | -55,5 |
| 174863__-174863__ | | 8-10-12 | 0 | 0 | 0 | 0 | 0 | 0 |
| 174865__-174865__ | | 8-10 | -104 | -106 | -109 | -114 | -104 | -111 |
| 174863__-174874__ | | 8 10 12 | +44 +46 +44 | +45 +47 +49 | +46 +48 +50 | +49 +51 +53 | +50 +52 +54 | +55 +57 +59 |
| 174865__-174874__ | | 8 10 | -1,5 -3,5 | -1,5 -3,5 | -1,5 -3,5 | -1,5 -3,5 | -4,5 -6,5 | -4,5 -6,5 |
| 174878__-174874__ | | 8 10 12 | +43 +45 +47 | +44 +46 +48 | +45 +47 +49 | +48 +50 +52 | +49 +51 +53 | +54 +56 +58 |



■ Zinkdruckguss | zinc die cast

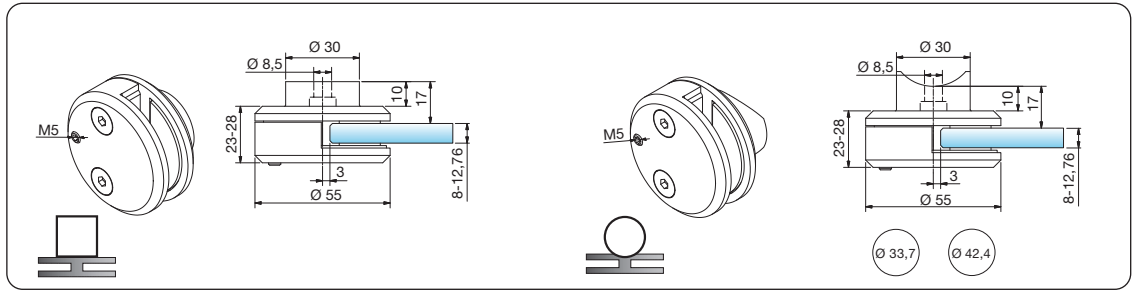

| Art. Nr. item no. | VSG | Mono | Sicherheit safety |
|----------------------|-----------------|-----------|----------------------|
| 174860__ | 8,76 - 12,76 mm | 8 - 12 mm | |
| 174861__ | 8,76 - 12,76 mm | 8 - 12 mm | R17,5/R23 |

| Farbe colour | | | | |
|----------------|----|----|----|----|
| | | | | |
| 01 | 02 | 03 | 09 | 04 |
| | | | | |
| 07 | 08 | | | |

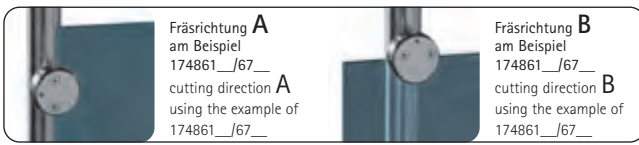

Bei Bestellung bitte Fräsrichtung und Rundrohrdurchmesser angeben.
When ordering, please indicate the cutting direction and tube diameter.

■ Edelstahl (A2) | stainless steel (A2)

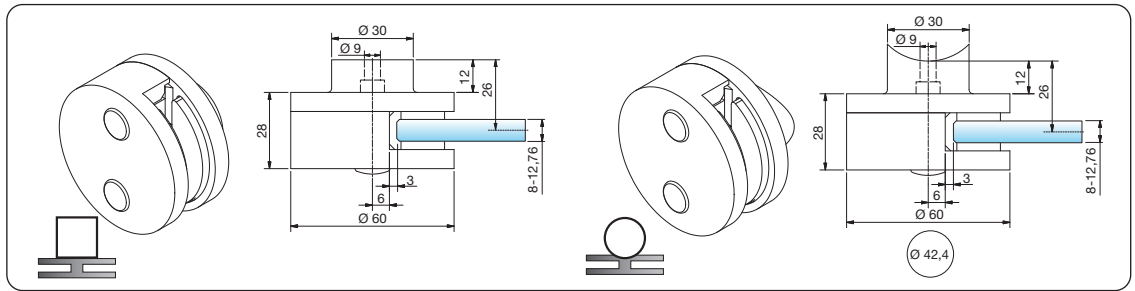

| Art. Nr. item no. | VSG | Mono | |
|----------------------|----------|-------|-----|
| 170066__ | | 8 mm | |
| 170067__ | 8,76 mm | | |
| 170068__ | 9,52 mm | | |
| 170069__ | | 10 mm | |
| 170070__ | 10,76 mm | | |
| 170071__ | 11,52 mm | | |
| 170072__ | | 12 mm | |
| 170073__ | 12,76 mm | | |
| 170074__ | | 8 mm | R21 |
| 170075__ | 8,76 mm | | R21 |
| 170076__ | 9,52 mm | | R21 |
| 170077__ | | 10 mm | R21 |
| 170078__ | 10,76 mm | | R21 |
| 170079__ | 11,52 mm | | R21 |
| 170080__ | | 12 mm | R21 |
| 170081__ | 12,76 mm | | R21 |

| Farbe colour |
|----------------|
| |
| 11 |



■ Zinkdruckguss | zinc die cast

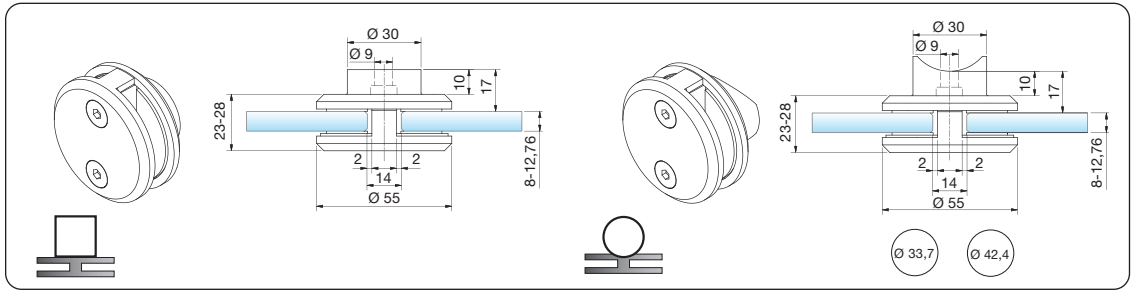

| Art. Nr. item no. | VSG | Mono | Sicherheit safety |
|----------------------|-----------------|-----------|----------------------|
| 174866__ | 8,76 - 12,76 mm | 8 - 12 mm | |
| 174867__ | 8,76 - 12,76 mm | 8 - 12 mm | R17,5/R23 |



Farbe | colour

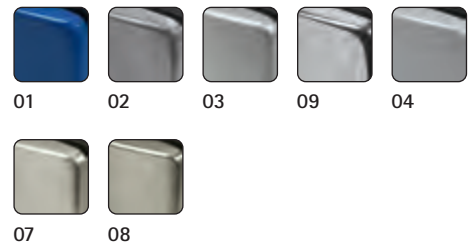

■ Edelstahl (A2) | stainless steel (A2)

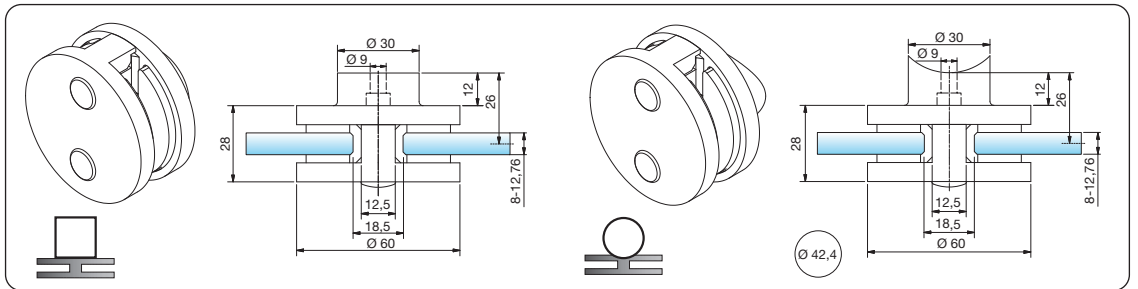

| Art. Nr. item no. | VSG | Mono | Sicherheit safety |
|----------------------|----------|-------|----------------------|
| 170082__ | | 8 mm | |
| 170083__ | 8,76 mm | | |
| 170084__ | 9,52 mm | | |
| 170085__ | | 10 mm | |
| 170086__ | 10,76 mm | | |
| 170087__ | 11,52 mm | | |
| 170088__ | | 12 mm | |
| 170089__ | 12,76 mm | | |
| 170090__ | | 8 mm | R21 |
| 170091__ | 8,76 mm | | R21 |
| 170092__ | 9,52 mm | | R21 |
| 170093__ | | 10 mm | R21 |
| 170094__ | 10,76 mm | | R21 |
| 170095__ | 11,52 mm | | R21 |
| 170096__ | | 12 mm | R21 |
| 170097__ | 12,76 mm | | R21 |

Farbe | colour





■ Verbinder aus Zinkdruckguss | connector zinc die cast

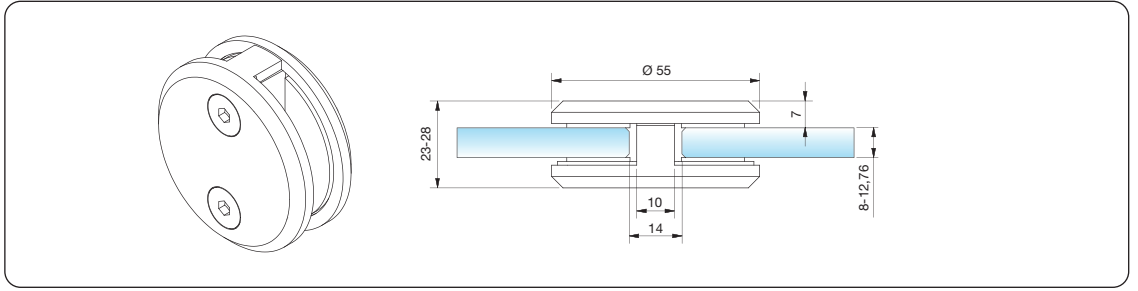

| Art. Nr. item no. | VSG | Mono |
|----------------------|-----------------|-----------|
| 174868__ | 8,76 - 12,76 mm | 8 - 12 mm |

| Farbe colour | | | | |
|----------------|----|----|----|----|
| | | | | |
| 01 | 02 | 03 | 09 | 04 |
| | | | | |
| 07 | 08 | | | |

■ Zinkdruckguss | zinc die cast

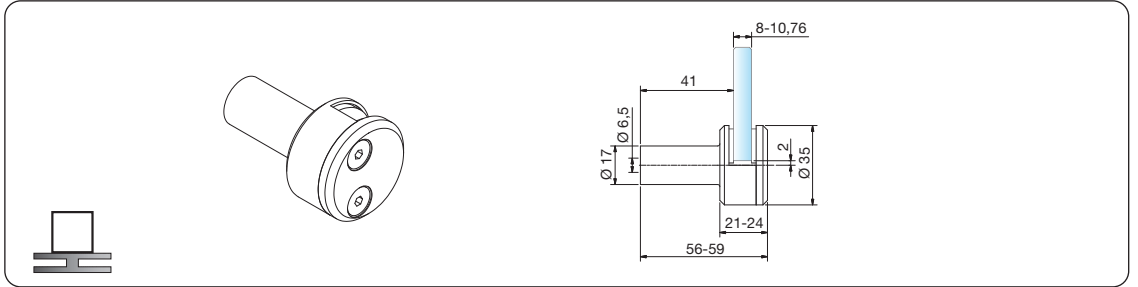

| Art. Nr. item no. | VSG | Mono | Sicherheit safety | | |
|----------------------|----------|-------|----------------------|--|--|
| 174840__ | 8,76 mm | 8 mm | | | |
| 174850__ | 10,76 mm | 10 mm | | | |

| Farbe colour | | | | |
|----------------|----|----|----|----|
| | | | | |
| 01 | 02 | 03 | 09 | 04 |
| | | | | |
| 07 | 08 | | | |





Zinkdruckguss | zinc die cast

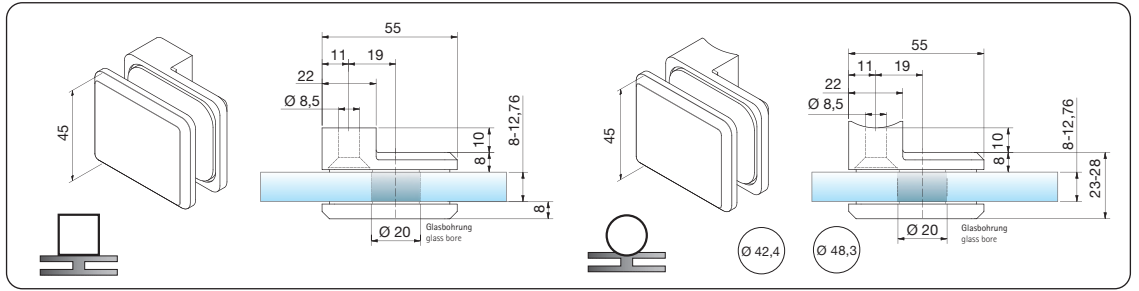

| Art. Nr. item no. | VSG | Mono | | |
|----------------------|-----------------|-----------|--|---------|
| 174862__ | 8,76 - 12,76 mm | 8 - 12 mm | | |
| 174863__ | 8,76 - 12,76 mm | 8 - 12 mm | | R20/R27 |

Farbe | colour

01 02 03 09 04

07 08

Verbinder aus Zinkdruckguss | zinc die cast connector

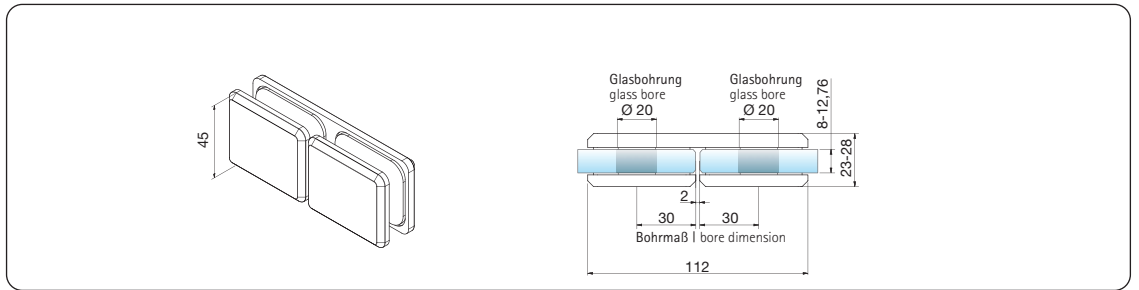

| Art. Nr. item no. | VSG | Mono |
|----------------------|-----------------|-----------|
| 174876__ | 8,76 - 12,76 mm | 8 - 12 mm |

Farbe | colour

01 02 03 09 04

07 08



■ Zinkdruckguss | zinc die cast

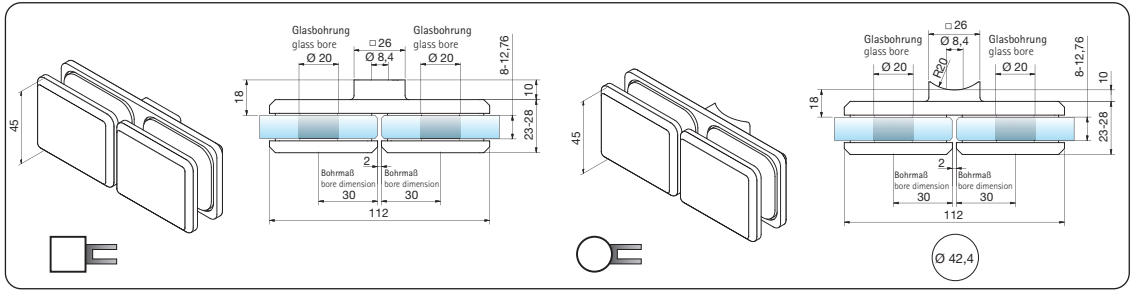

| Art. Nr. item no. | VSG | Mono | Ø 20 | Ø 20 R20 |
|----------------------|-----------------|-----------|------|----------|
| 174877__ | 8,76 - 12,76 mm | 8 - 12 mm | | |
| 174878__ | 8,76 - 12,76 mm | 8 - 12 mm | | |

| Farbe colour | | | | |
|----------------|----|----|----|----|
| | | | | |
| 01 | 02 | 03 | 09 | 04 |
| | | | | |
| 07 | 08 | | | |

■ Zinkdruckguss | zinc die cast

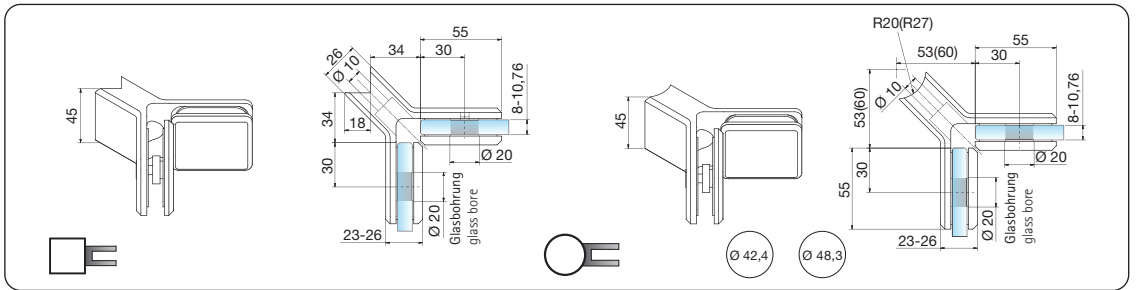

| Art. Nr. item no. | VSG | Mono | Ø 20 | Ø 20 R20/R27 |
|----------------------|-----------------|-----------|------|--------------|
| 174864__ | 8,76 - 10,76 mm | 8 - 10 mm | | |
| 174865__ | 8,76 - 10,76 mm | 8 - 10 mm | | |

| Farbe colour | | | | |
|----------------|----|----|----|----|
| | | | | |
| 01 | 02 | 03 | 09 | 04 |
| | | | | |
| 07 | 08 | | | |



■ Zinkdruckguss | zinc die cast

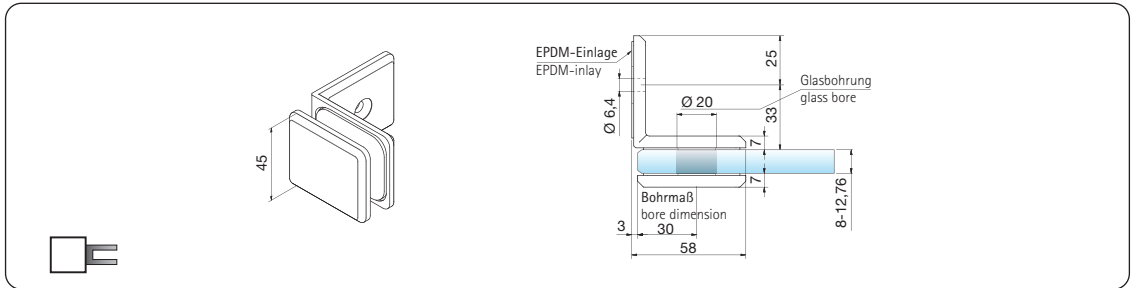

| | | | |
|----------------------|-----------------|-----------|----------------------|
| Art. Nr. item no. | VSG | Mono | Sicherheit safety |
| 174875__ | 8,76 - 12,76 mm | 8 - 12 mm | |



Farbe | colour

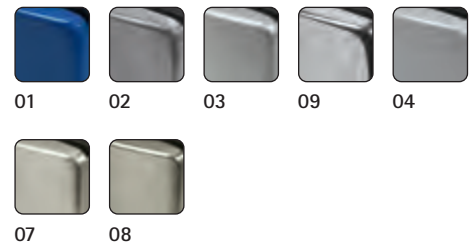

■ Zinkdruckguss | zinc die cast

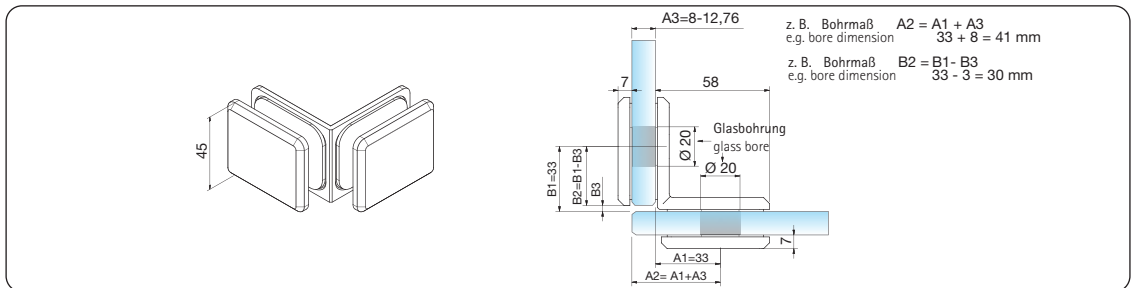
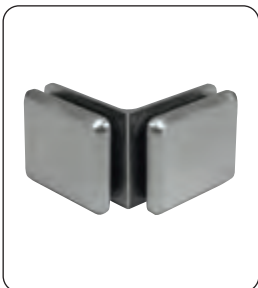

| | | | |
|----------------------|-----------------|-----------|----------------------|
| Art. Nr. item no. | VSG | Mono | Sicherheit safety |
| 174874__ | 8,76 - 12,76 mm | 8 - 12 mm | |



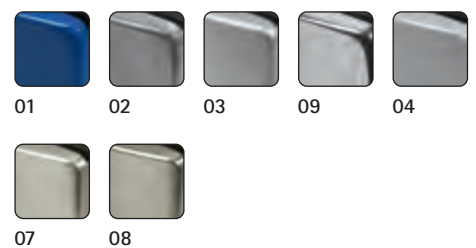

Farbe | colour





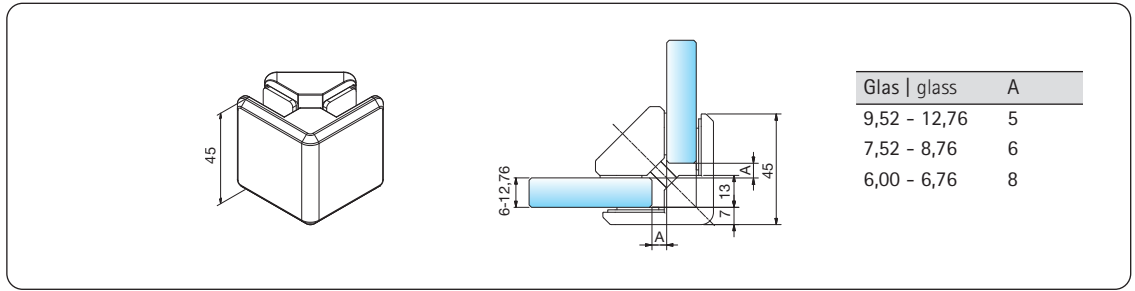





■ Verbinder aus Zinkdruckguss | zinc die cast connector









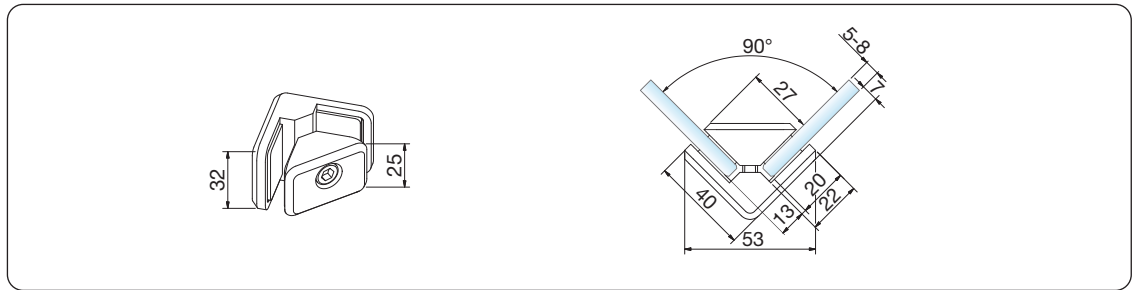

| Art. Nr. item no. | VSG  | Mono  |
|----------------------|---|--|
| 174830__ | 6,76 - 12,76 mm | 6 - 12 mm |

| Farbe colour | | | | |
|---|---|---|---|---|
|  |  |  |  |  |
| 01 | 02 | 03 | 09 | 04 |
|  |  | | | |
| 07 | 08 | | | |

■ Verbinder aus Zinkdruckguss | zinc die cast connector



| Art. Nr. item no. | Info | Mono  |
|----------------------|---|--|
| 174880__ | Winkelverbinder 90° corner bracket 90° | 5 - 8 mm |

| Farbe colour | | | | |
|---|---|---|---|---|
|  |  |  |  |  |
| 01 | 02 | 03 | 09 | 04 |
|  |  | | | |
| 07 | 08 | | | |





■ Verbinder aus Zinkdruckguss | zinc die cast connector

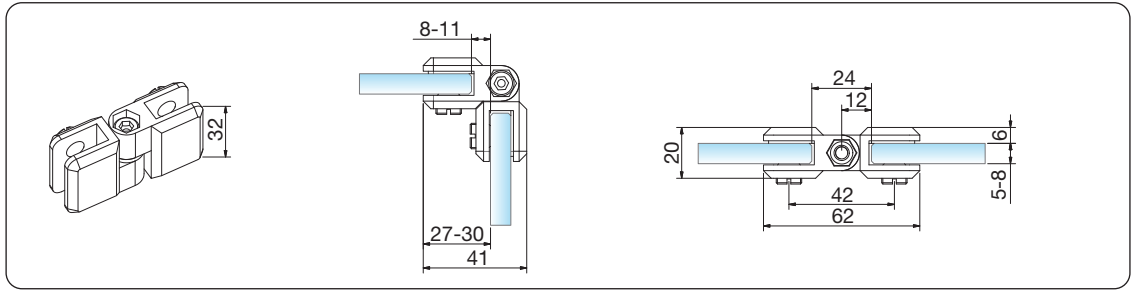

| Art. Nr. item no. | Info | Mono  |
|----------------------|---|--|
| 174885__ | Scharnier und variabler Verbinder, 90° - 270° hinge and variable connector, opening angle 90° - 270° | 5 - 8 mm |

Farbe | colour

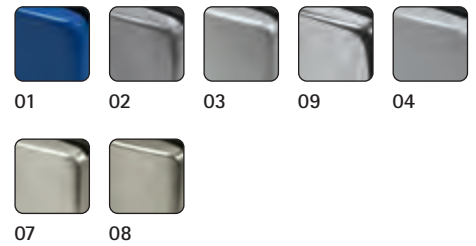



■ Punkthalter aus Zinkdruckguss | zinc die cast point fixing

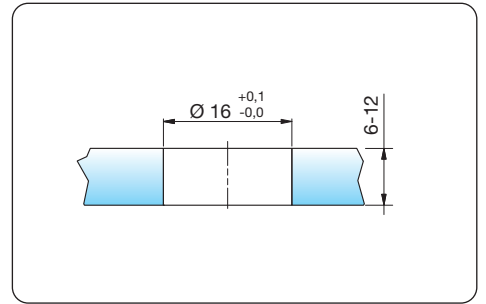
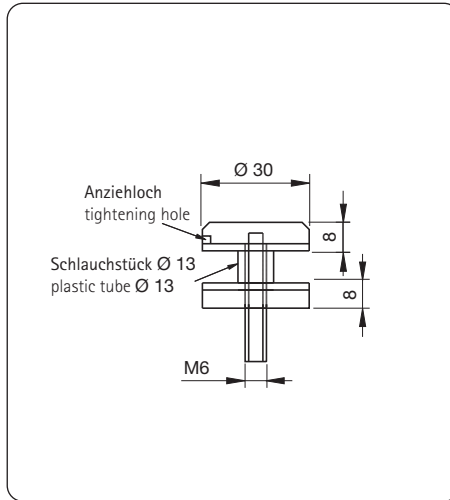

Art. Nr.: | item no.: 174870__ / 174872__

Punkthalter Ø 30 erhaben
point fixing Ø 30 raised head

Material: Zink | zinc

Zubehör | accessories
17021400

inklusive | includes
174870__ M6x60 mm 174872__ 6x60 mm

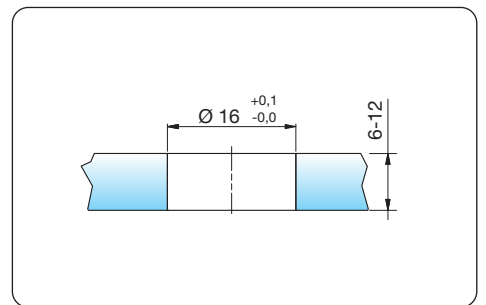
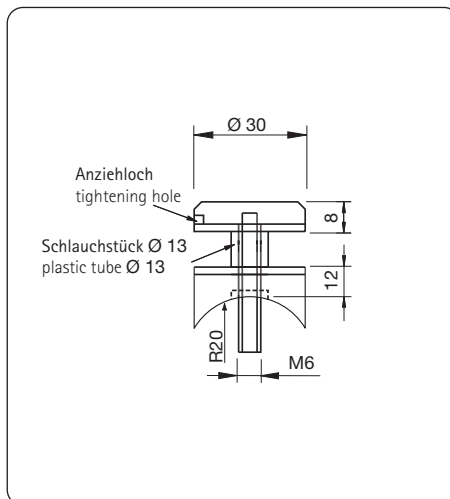
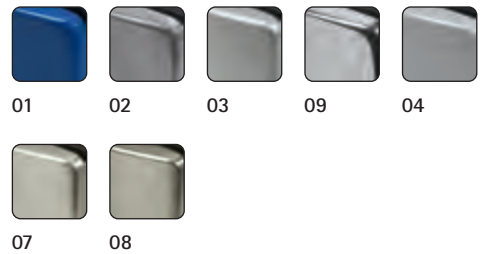

Art. Nr.: | item no.: 174871__

Punkthalter Ø 30 erhaben
point fixing Ø 30 raised head

Material: Zink | zinc

Zubehör | accessories
17021400

inklusive | includes
174871__ M6x60 mm

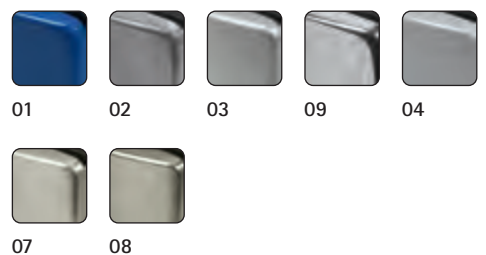



■ Punkthalter aus Edelstahl (A2) | stainless steel point fixing (A2)



Zubehör | accessories



17021400

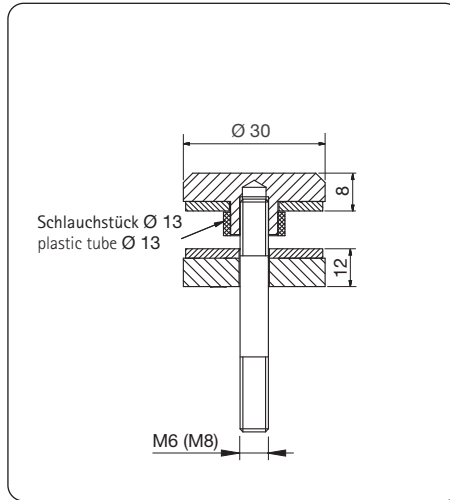

inklusive | includes
170211__ (170212__)
M6(M8)x60 mm

170213__
6x60 mm

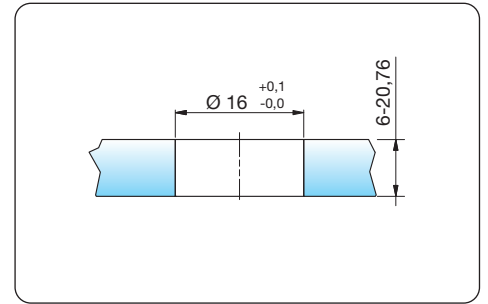

Art. Nr.: | item no.:
170211__ /170212__ /170213__

Punkthalter Ø 30 erhaben
point fixing Ø 30 raised head

Material: A2 (1.4301)



22 10



Zubehör | accessories



17021400

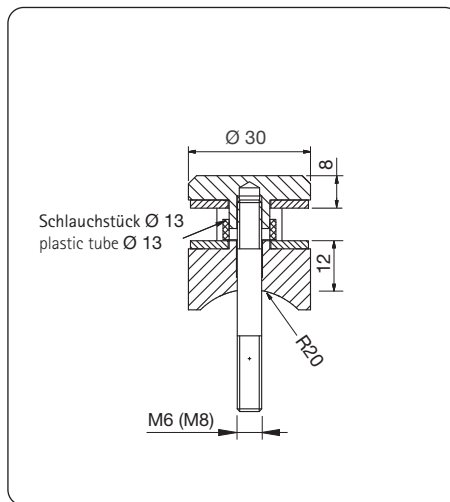

inklusive | includes
170204__ (170205__)
M6(M8)x60 mm

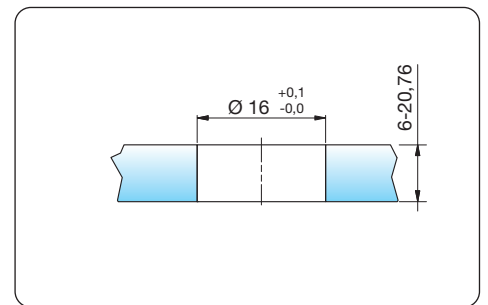

Art. Nr.: | item no.: 170204__ / 170205__

Punkthalter Ø 30 erhaben
point fixing Ø 30 raised head

Material: A2 (1.4301)



22 10

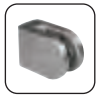
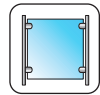

■ Inhalt | content

- Brüstungsverglasung mit cp-mini | balustrade glazing with cp-mini ... 46-51

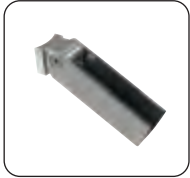

INFO

Informationen zu cp-mini finden Sie auf Seite 243

For information about cp-mini please see page 243





■ Brüstungsverglasung mit cp-mini
balustrade glazing with cp-mini



■ Brüstungsverglasung cp-mini für Rechteckrohr | balustrade glazing with cp-mini for square tube

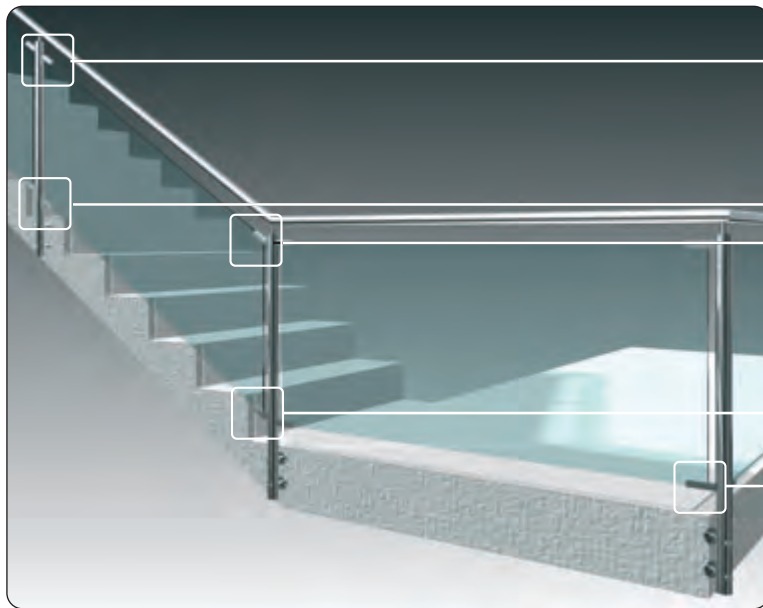

119424
cp-mini oben R22
30°-41° schräg
cp-mini at the top
30°-41° angular



119422
cp-mini unten R22
30°-41° schräg
cp-mini at the bottom R22
30°-41° angular



119423
cp-mini oben R22
139°-150° schräg
cp-mini at the top
139°-150° angular

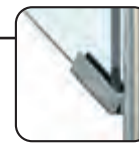

119421
cp-mini unten R22
139°-150° schräg
cp-mini at the bottom R22
139°-150° angular



119420
cp-mini R22
180° gerade
180° straight

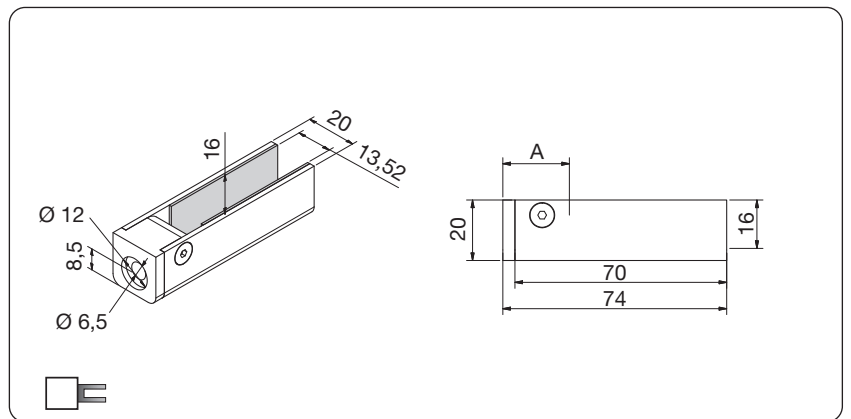

| Art. Nr. item no. | Material | Info | VSG | | | |
|---------------------|----------|------------------------|----------|--|--|--|
| 11941000 | A2 | 180° gerade straight | 13,52 mm | | | |

A = Abzugsmaß Glas 24 mm/
Befestigungsschraube DIN 6912 M6
A = reduction measurement glass 24
mm/fastening screw DIN 6912 M6

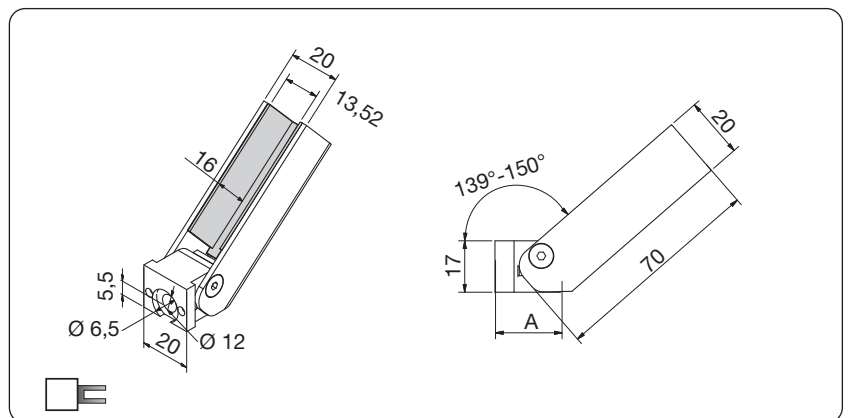

| Art. Nr. item no. | Material | Info | VSG | | | |
|---------------------|----------|------------------------------|----------|--|--|--|
| 11941100 | A2 | 139° - 150° schräg angular | 13,52 mm | | | |

A = Abzugsmaß Glas 24 mm/
Befestigungsschraube DIN 6912 M6
A = reduction measurement glass 24
mm/fastening screw DIN 6912 M6





■ Brüstungsverglasung cp-mini für Rechteckrohr | balustrade glazing with cp-mini for square tube

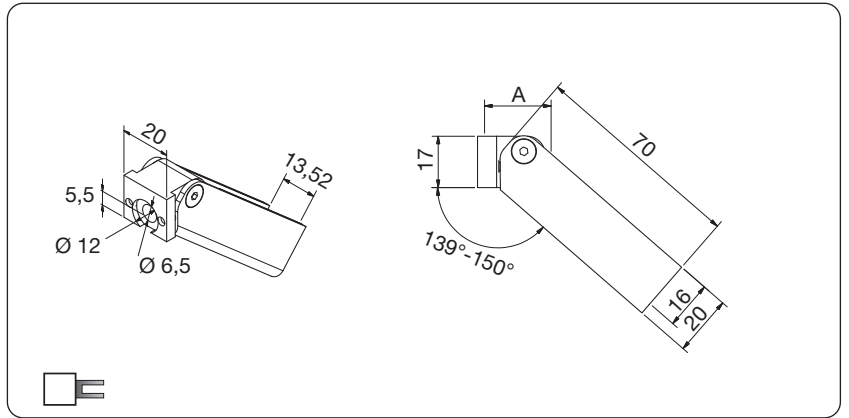

| Art. Nr. item no. | Material | Info | VSG | | | |
|---------------------|----------|----------------------------|----------|--|--|--|
| 11941200 | A2 | 30° - 41° schräg angular | 13,52 mm | | | |

A = Abzugsmaß Glas 24 mm/
Befestigungsschraube DIN 6912 M6
A = reduction measurement glass 24
mm/fastening screw DIN 6912 M6

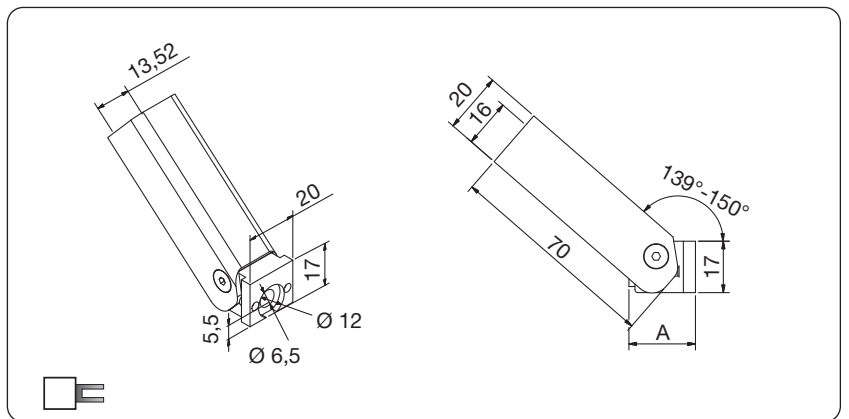

| Art. Nr. item no. | Material | Info | VSG | | | |
|---------------------|----------|------------------------------|----------|--|--|--|
| 11941300 | A2 | 139° - 150° schräg angular | 13,52 mm | | | |

A = Abzugsmaß Glas 24 mm/
Befestigungsschraube DIN 6912 M6
A = reduction measurement glass 24
mm/fastening screw DIN 6912 M6

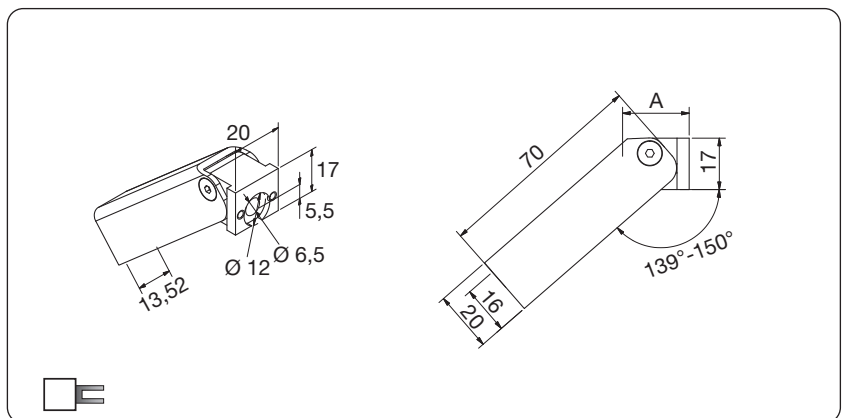

| Art. Nr. item no. | Material | Info | VSG | | | |
|---------------------|----------|----------------------------|----------|--|--|--|
| 11941400 | A2 | 30° - 41° schräg angular | 13,52 mm | | | |

A = Abzugsmaß Glas 24 mm/
Befestigungsschraube DIN 6912 M6
A = reduction measurement glass 24
mm/fastening screw DIN 6912 M6

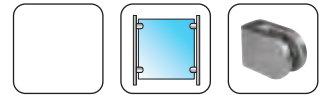

■ Brüstungsverglasung cp-mini für Rundrohr | balustrade glazing with cp-mini for round tube

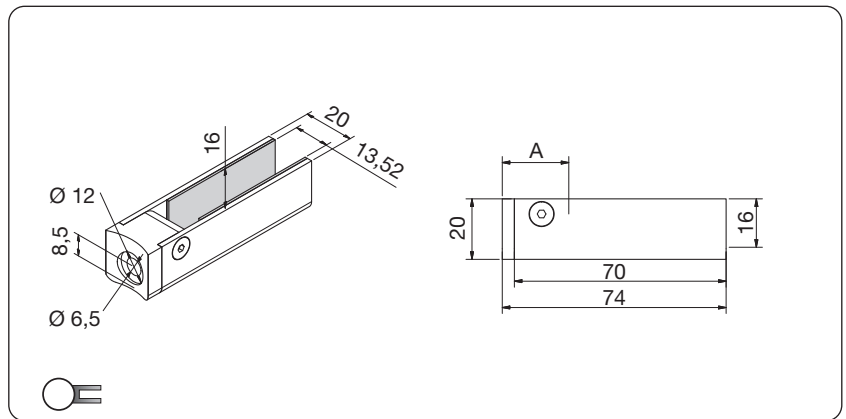

| Art. Nr. item no. | Material | Info | VSG | | | |
|---------------------|----------|------------------------|----------|--|--|-----|
| 11942000 | A2 | 180° gerade straight | 13,52 mm | | | R22 |

A = Abzugsmaß Glas 24 mm/
Befestigungsschraube DIN 6912 M6
A = reduction measurement glass 24
mm/fastening screw DIN 6912 M6

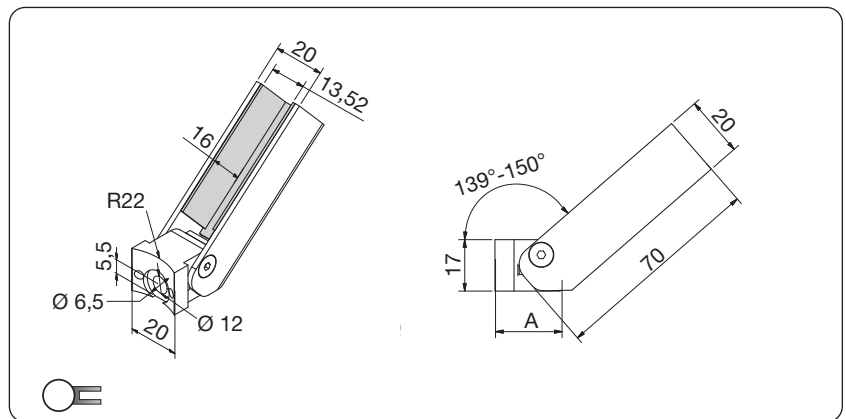

| Art. Nr. item no. | Material | Info | VSG | | | |
|---------------------|----------|------------------------------|----------|--|--|-----|
| 11942100 | A2 | 139° - 150° schräg angular | 13,52 mm | | | R22 |

A = Abzugsmaß Glas 24 mm/
Befestigungsschraube DIN 6912 M6
A = reduction measurement glass 24
mm/fastening screw DIN 6912 M6

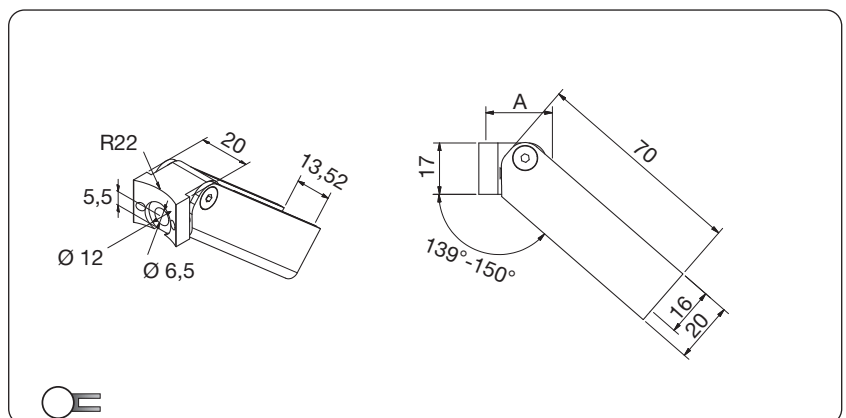

| Art. Nr. item no. | Material | Info | VSG | | | |
|---------------------|----------|----------------------------|----------|--|--|-----|
| 11942200 | A2 | 30° - 41° schräg angular | 13,52 mm | | | R22 |

A = Abzugsmaß Glas 24 mm/
Befestigungsschraube DIN 6912 M6
A = reduction measurement glass 24
mm/fastening screw DIN 6912 M6





■ Brüstungsverglasung cp-mini für Rundrohr | balustrade glazing with cp-mini for round tube

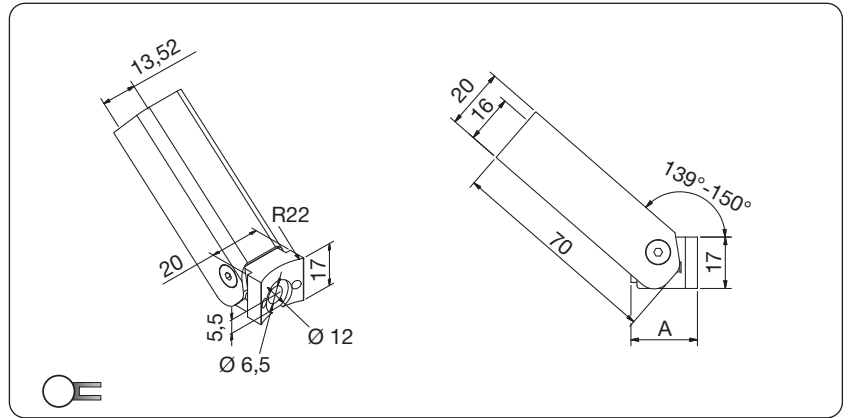

| Art. Nr. item no. | Material | Info | VSG | | | |
|---------------------|----------|------------------------------|----------|--|--|--|
| 11942300 | A2 | 139° - 150° schräg angular | 13,52 mm | | | |

A = Abzugsmaß Glas 24 mm/
Befestigungsschraube DIN 6912 M6
A = reduction measurement glass 24
mm/fastening screw DIN 6912 M6

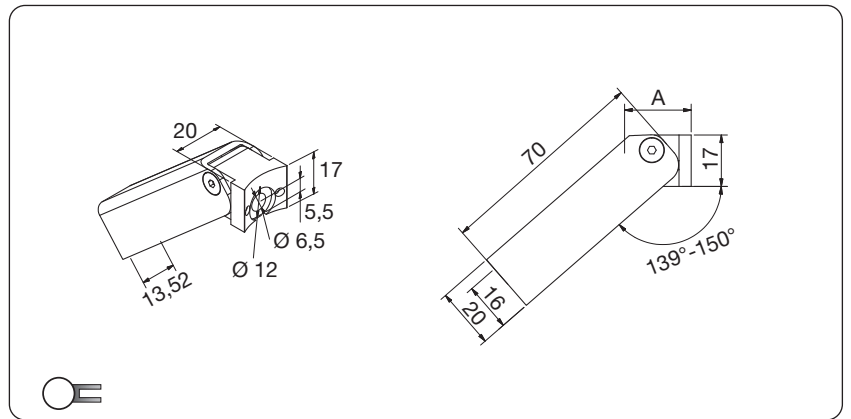

| Art. Nr. item no. | Material | Info | VSG | | | |
|---------------------|----------|----------------------------|----------|--|--|--|
| 11942400 | A2 | 30° - 41° schräg angular | 13,52 mm | | | |

A = Abzugsmaß Glas 24 mm/
Befestigungsschraube DIN 6912 M6
A = reduction measurement glass 24
mm/fastening screw DIN 6912 M6

■ INFO



Anwendung cp-minis | application cp-minis

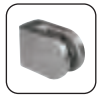
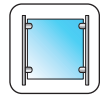

■ Inhalt | content

- Punkthalter nach TRAV | point fixings according to TRAV 52-57



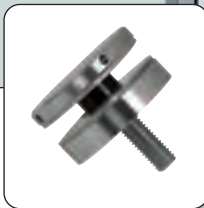

■ Brüstungsverglasung mit TRAV-Haltern
balustrade glazing according to TRAV

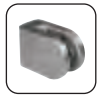
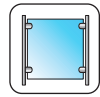

■ Punkthalter nach TRAV | point fixings according to TRAV

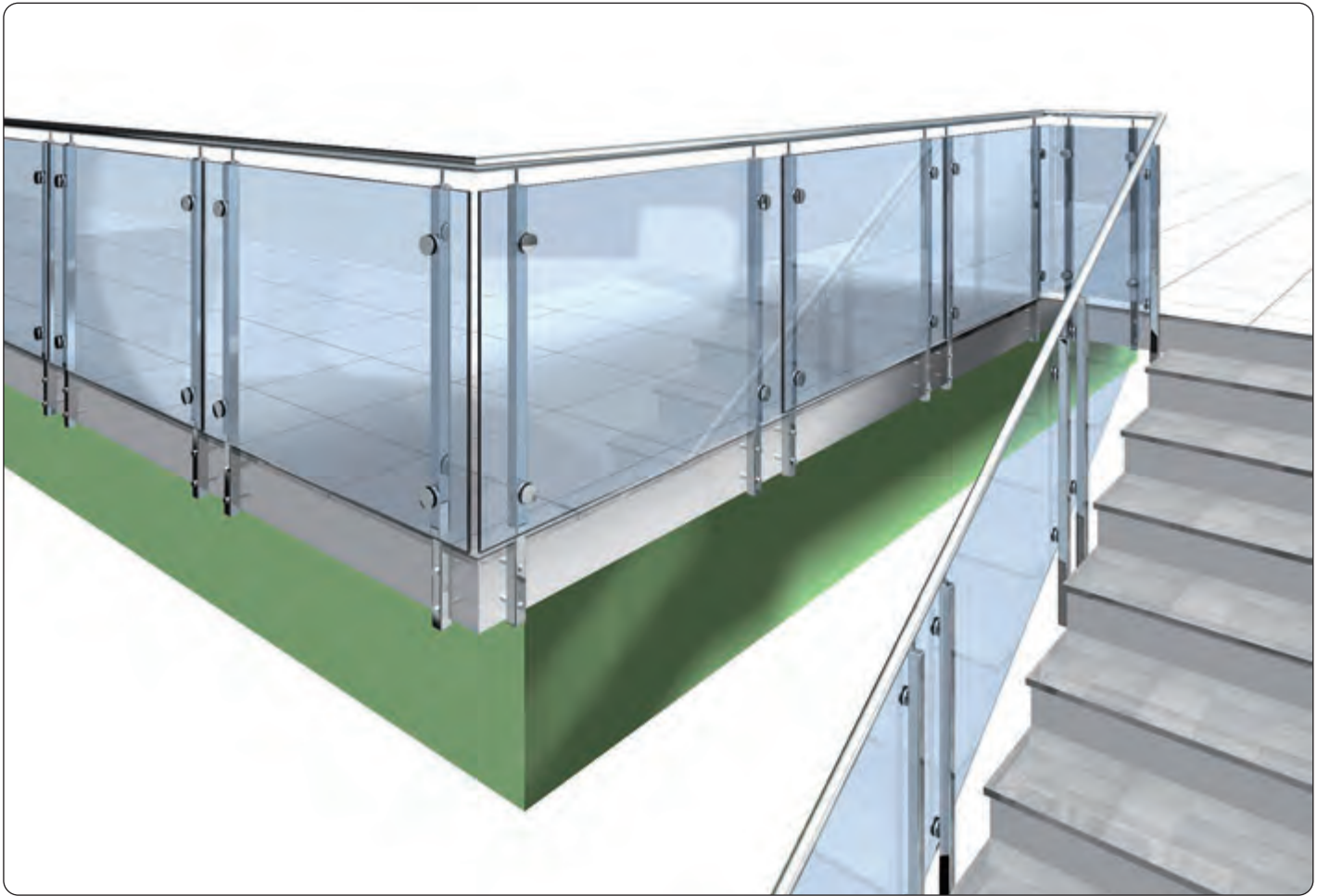

■ Haltersysteme für Punkthalter nach TRAV | support systems with straps according to TRAV



Im Objektbereich können wir individuelle TRAV-Laschen für Sie fertigen. Fragen Sie Ihr eigenes Design an.

For large projects, we can fabricate custom TRAV-arms for your individual needs. We can make you an offer with your own design.





■ Punkthalter nach TRAV | point fixing according to TRAV



Zubehör | accessories
 17012700 M8

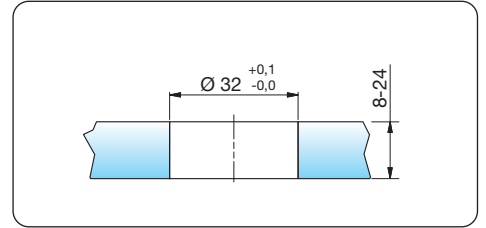
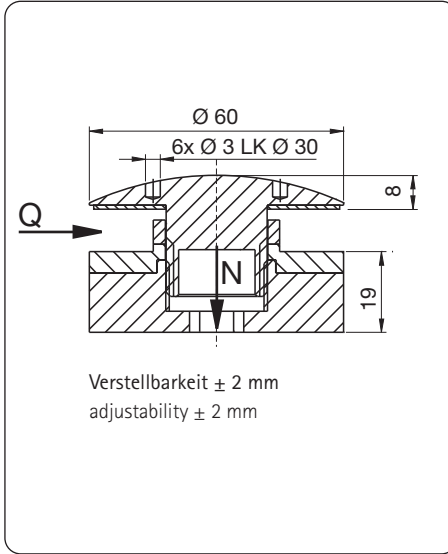

Art. Nr.: | item no.: 13910400

| | |
|---|------------------------|
| Punkthalter (TRAV) point fixing (TRAV) | erhaben raised head |
| Material: | A2 (1.4301) |
| max. Q: 4,0 kN | max. N: 6,0 kN |
| 13910400-12 | 8 - 12 mm |
| 13910400-16 | 13 - 16 mm |
| 13910400-20 | 17 - 20 mm |
| 13910400-24 | 21 - 24 mm |



inklusive | includes
 DIN7991* M10 x 70 mm

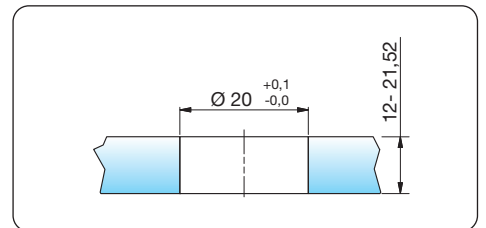
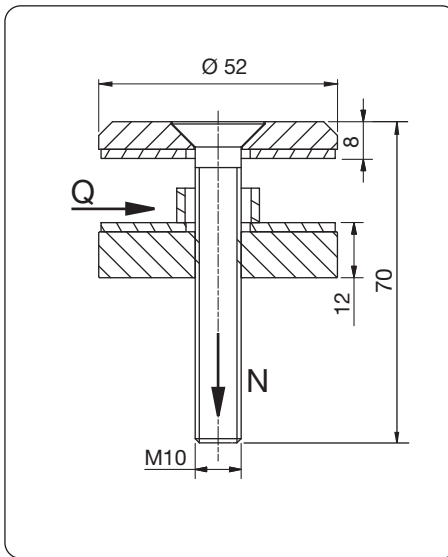

Art. Nr.: | item no.: 13901100

| | |
|---|------------------------|
| Punkthalter (TRAV) point fixing (TRAV) | erhaben raised head |
| Material: | A2 (1.4301) |
| max. Q: 4,0 kN | max. N: 6,0 kN |



■ Punkthalter nach TRAV | point fixings according to TRAV

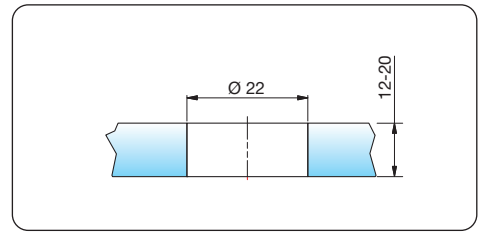
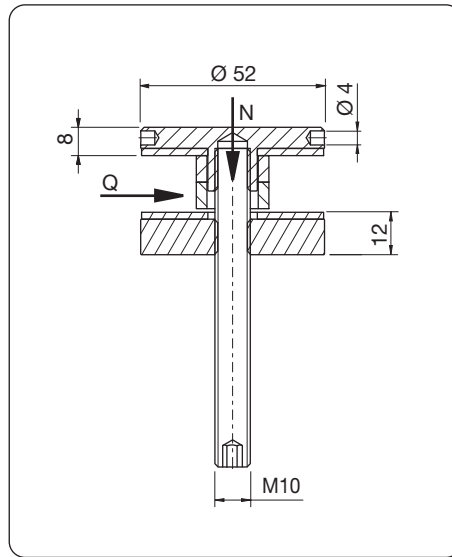

Art. Nr.: | item no.: 13900700

| | |
|---|------------------------|
| Punkthalter (TRAV) point fixing (TRAV) | erhaben raised head |
| Kopfform head: | flach flat |
| Material: | A2 (1.4301) |
| max. Q: 4,0 kN | max. N: 6,0 kN |

Zubehör | accessories
17012800

inklusive | includes
DIN913 M10 x 90 mm

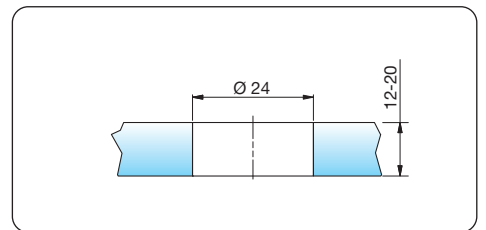
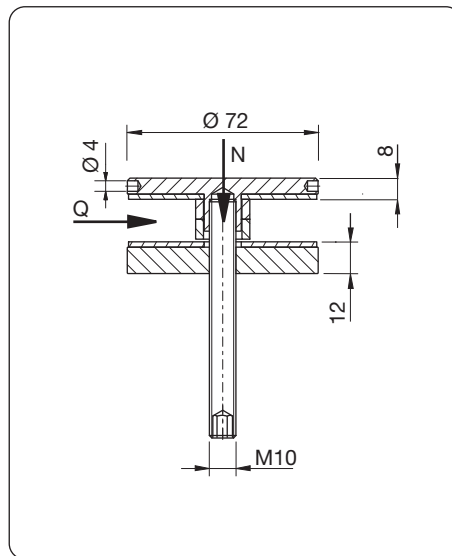

Art. Nr.: | item no.: 13900900

| | |
|---|------------------------|
| Punkthalter (TRAV) point fixing (TRAV) | erhaben raised head |
| Kopfform head: | flach flat |
| Material: | A2 (1.4301) |
| max. Q: 4,0 kN | max. N: 6,0 kN |

Zubehör | accessories
17012800

inklusive | includes
DIN913 M10 x 90 mm



■ Punkthalter nach TRAV | point fixings according to TRAV

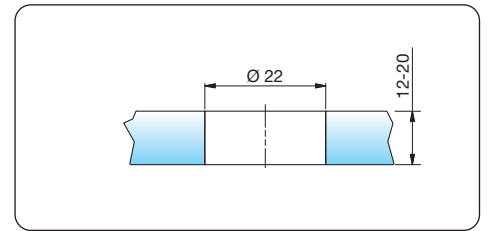
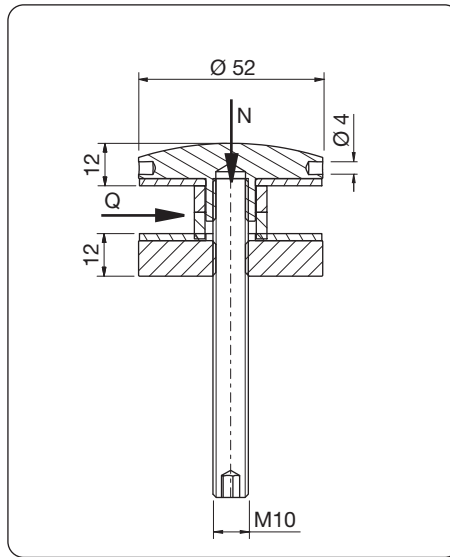

Art. Nr.: | item no.: 13900800

| | |
|---|------------------------|
| Punkthalter (TRAV) point fixing (TRAV) | erhaben raised head |
| Kopfform head: | gerundet rounded |
| Material: | A2 (1.4301) |
| max. Q: 4,0 kN | max. N: 6,0 kN |

Zubehör | accessories
17012800

inklusive | includes
DIN913 M10 x 90 mm

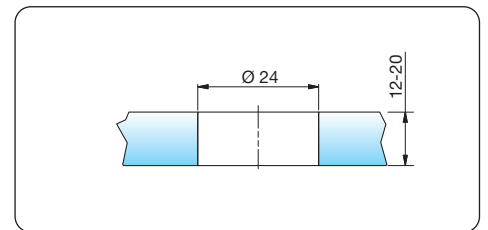
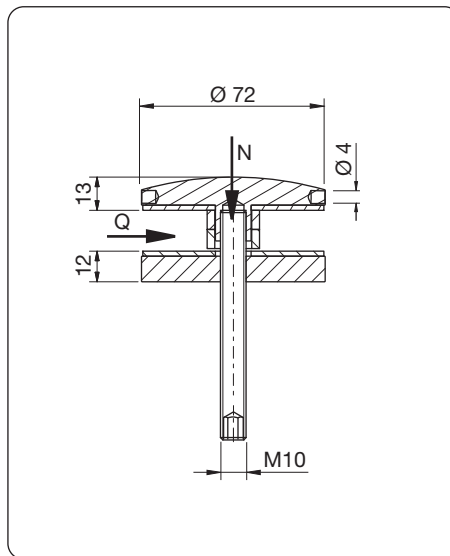

Art. Nr.: | item no.: 13901000

| | |
|---|------------------------|
| Punkthalter (TRAV) point fixing (TRAV) | erhaben raised head |
| Kopfform head: | gerundet rounded |
| Material: | A2 (1.4301) |
| max. Q: 4,0 kN | max. N: 6,0 kN |

Zubehör | accessories
17012800

inklusive | includes
DIN913 M10 x 90 mm

■ INFO

Anwendung TRAV | application TRAV

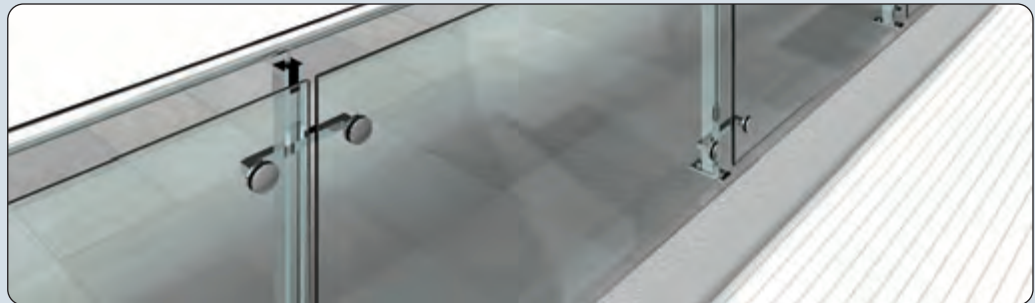

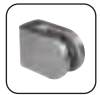
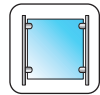

■ Inhalt | content

■ Punkthaltersystem Banano | point-fixed system Banano 58-63



INFO

Informationen zur Statik von Banano
finden Sie auf Seite 234
For information about the statics of
Banano please see page 234



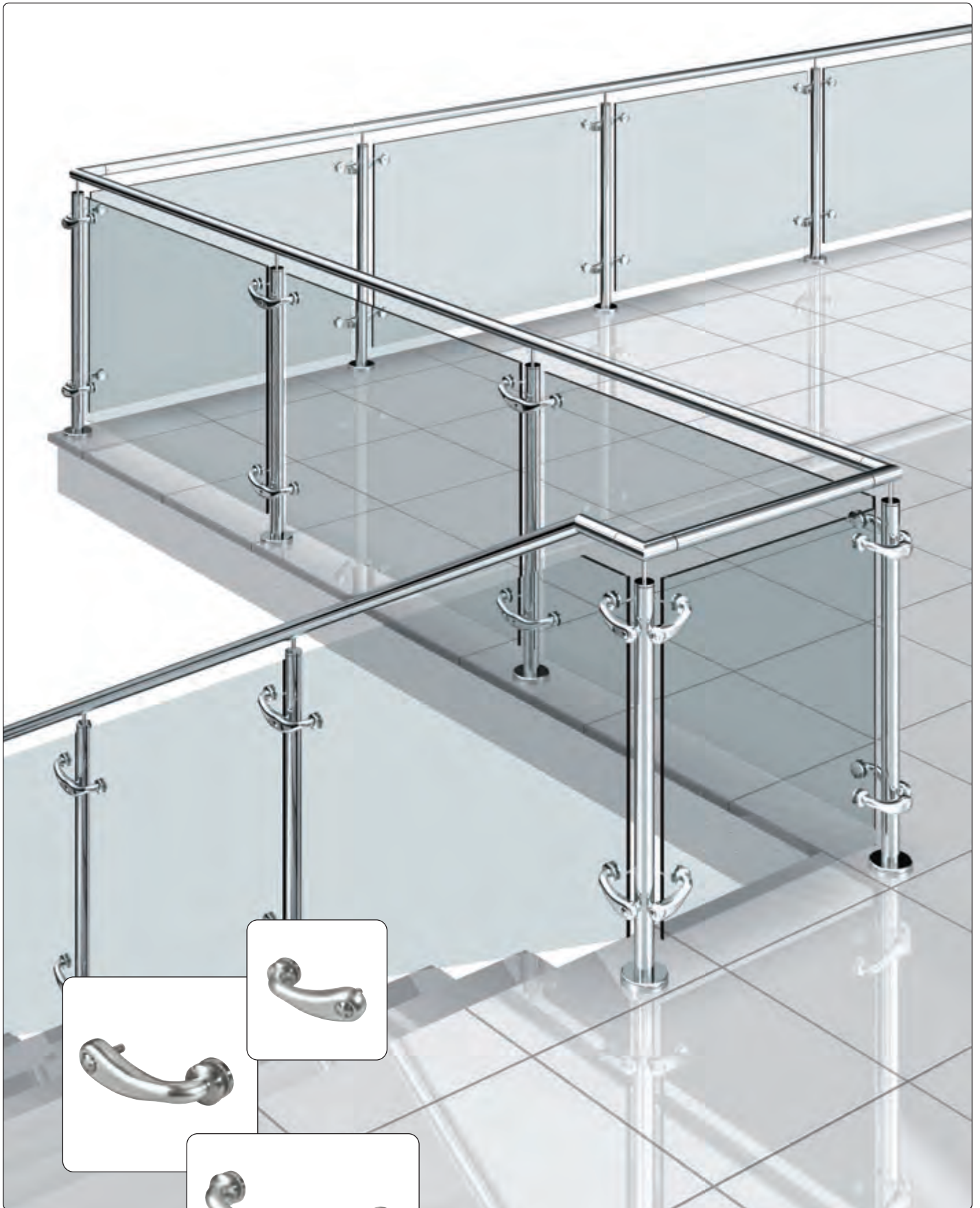

■ Punkthaltersystem Banano
point-fixed system Banano



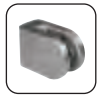
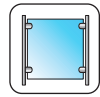

■ Systematik und Kombinationsmöglichkeiten mit Banano | systematics and combination possibilities with Banano

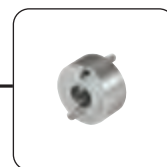
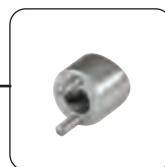
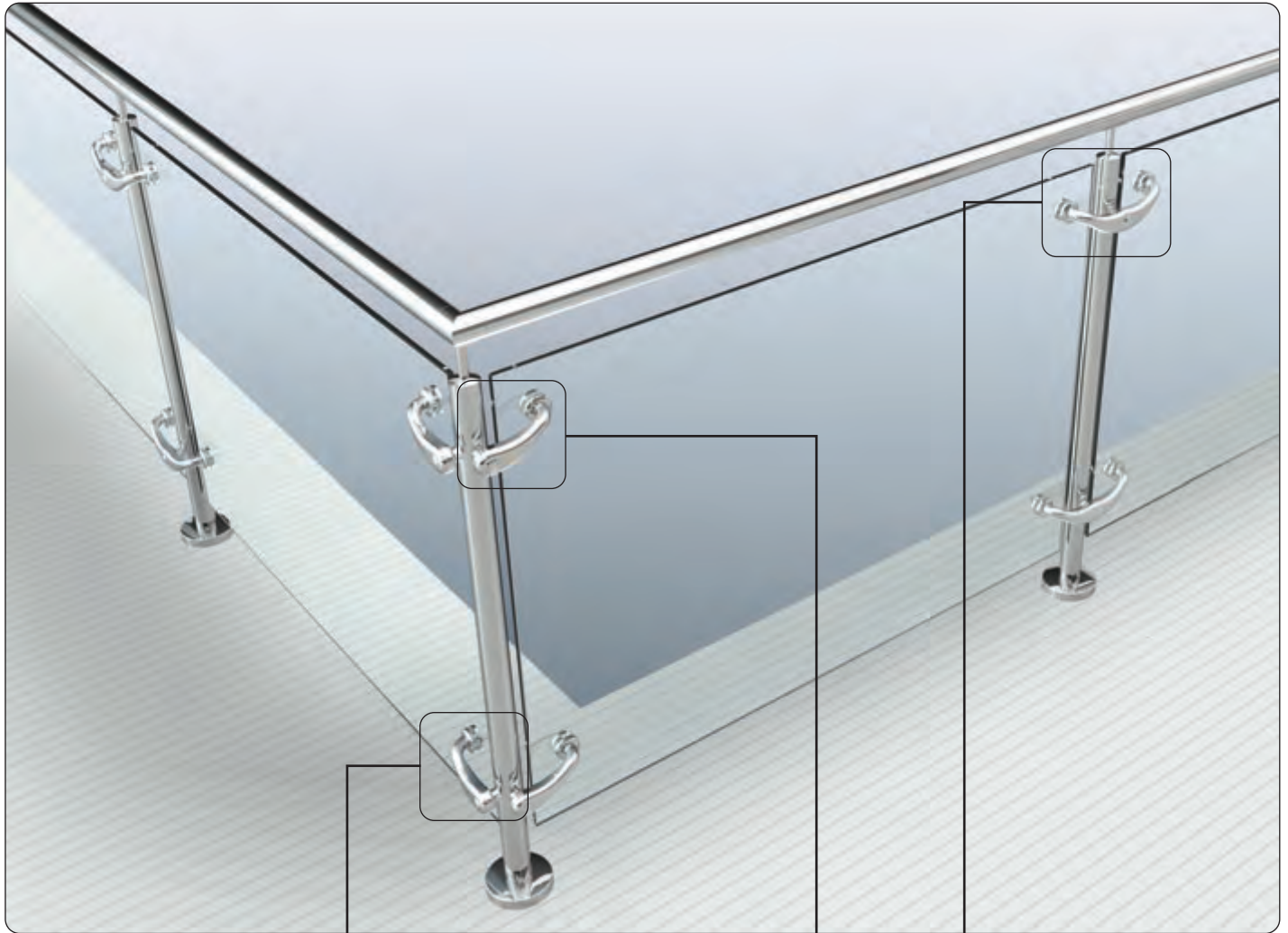



■ Verbinder Banano | connector Banano

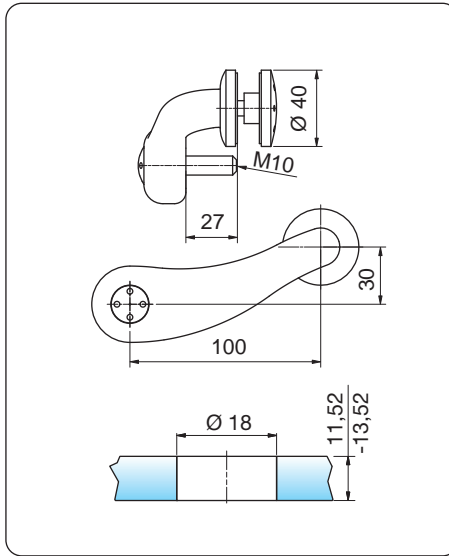

Art. Nr.: | item no.: 170098__

| | |
|-------------------------------|--|
| Endverbinder end connector | rechte Ausführung right-hand version |
| Material: | Zinkdruckguss / A2 zinc die cast / A2 |

Farbe | colour

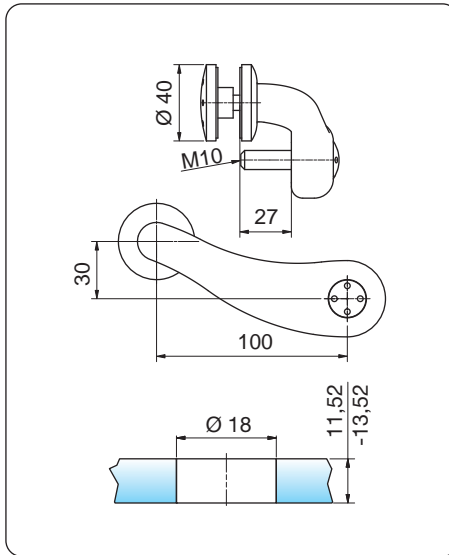

Art. Nr.: | item no.: 170099__

| | |
|-------------------------------|--|
| Endverbinder end connector | linke Ausführung left-hand version |
| Material: | Zinkdruckguss / A2 zinc die cast / A2 |

Farbe | colour

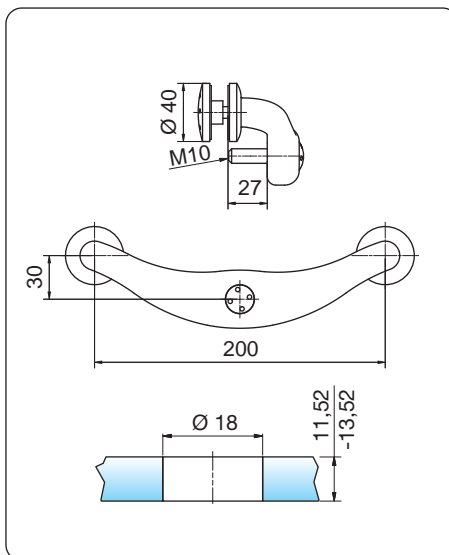

Art. Nr.: | item no.: 170100__

| | |
|-------------------------------------|--|
| Mittelverbinder middle connector | |
| Material: | Zinkdruckguss / A2 zinc die cast / A2 |

Farbe | colour





Adapter Banano | adapter Banano

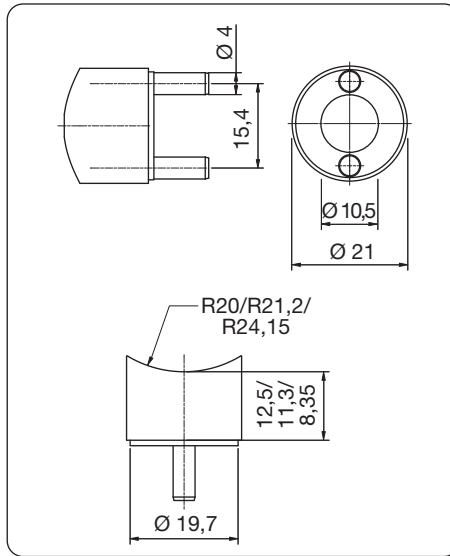

Art. Nr.: | item no.: 170101__

Rundrohradapter R20/R21,2/R24
 round tube adapter
 Material: Zinkdruckguss / A2
 zinc die cast / A2

Farbe | colour

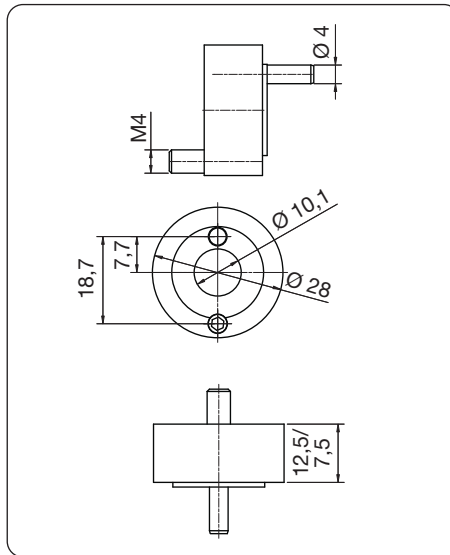

Art. Nr.: | item no.:
 170102__ -VK40/170102__ -VK50

Vierkantrohradapter 40 mm/50 mm
 square tube adapter
 Material: Zinkdruckguss / A2
 zinc die cast / A2

Farbe | colour





■ Rundrohrbefestigung Banano | round tube fixture Banano

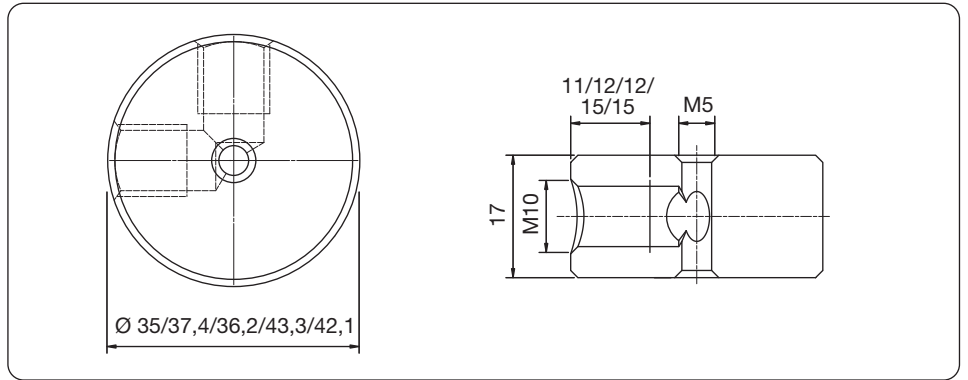

| Art. Nr. item no. | Info | Rohr tube Ø |
|---------------------|--|---------------|
| 11091300 | Rundrohrbefestigung round tube fixture | 40 x 2 |
| 11091500 | Rundrohrbefestigung round tube fixture | 42,4 x 2 |
| 11091700 | Rundrohrbefestigung round tube fixture | 42,4 x 2,6 |
| 11091900 | Rundrohrbefestigung round tube fixture | 48,3 x 2 |
| 11092100 | Rundrohrbefestigung round tube fixture | 48,3 x 2,6 |

| |
|--|
| Material Aluminium |
| für Artikel Nr. for item no. 170099/170098/170100 |

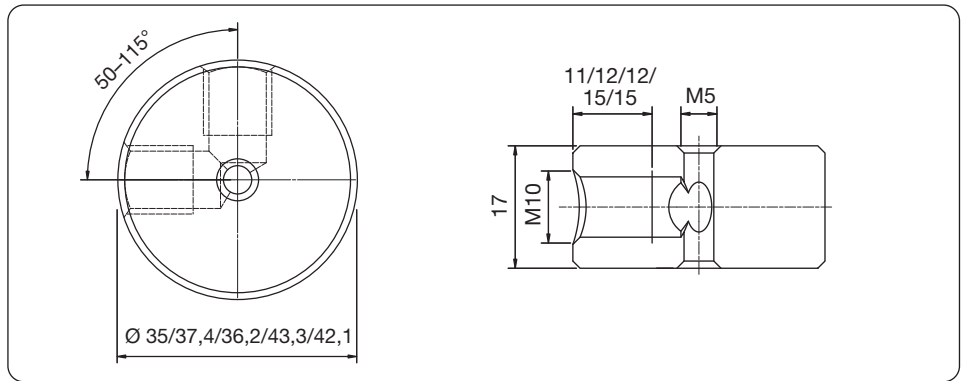

| Art. Nr. item no. | Info | Rohr tube Ø |
|---------------------|--|---------------|
| 11091400 | Rundrohrbefestigung round tube fixture | 40 x 2 |
| 11091600 | Rundrohrbefestigung round tube fixture | 42,4 x 2 |
| 11091800 | Rundrohrbefestigung round tube fixture | 42,4 x 2,6 |
| 11092000 | Rundrohrbefestigung round tube fixture | 48,3 x 2 |
| 11092200 | Rundrohrbefestigung round tube fixture | 48,3 x 2,6 |

| |
|--|
| Material Aluminium |
| für Artikel Nr. for item no. 170099/170098/170100 |

INFO

Bitte den Winkel zwischen den Bohrungen angeben. | Please state the angle between the drillings.

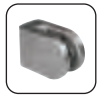
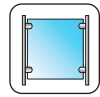

■ Inhalt | content

■ Zubehör Brüstungsverglasung 64-69
accessoires for balustrade glazing





■ Zubehör Brüstungsverglasung
accessories for balustrade glazing



Zubehör Brüstungsverglasung | accessories for balustrade glazing

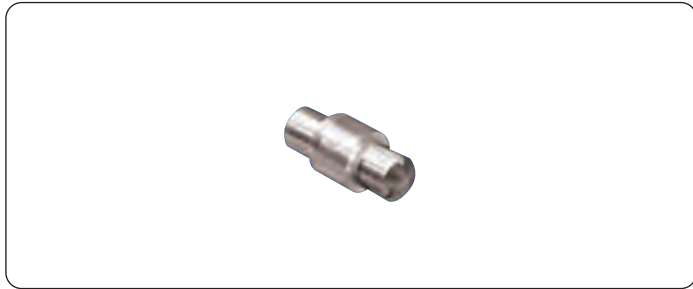

| Art. Nr. item no. | Info |
|---------------------|---|
| 17010300 | Ø 4 x 12 mm mit Schlauchstück with plastic tube |
| 17010400 | Ø 4 x 16 mm mit Schlauchstück with plastic tube |
| 17010500 | Ø 4 x 25 mm mit Schlauchstück with plastic tube |
| 17010600 | Ø 6 x 16 mm mit Schlauchstück with plastic tube |
| 17010700 | Ø 6 x 25 mm mit Schlauchstück with plastic tube |
| 17010800 | Ø 6 x 20 mm mit Schlauchstück with plastic tube |

Plattenbohrung | plate bore
min. Ø 10 mm
≥ Glasdicke | ≥ glass thickness

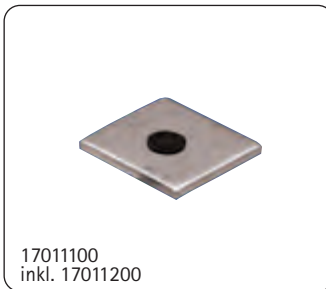
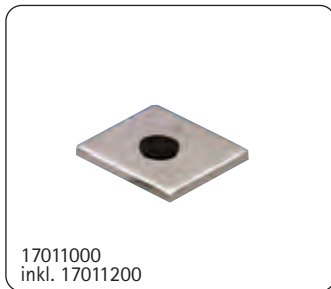

| Art. Nr. item no. | Info |
|---------------------|---|
| 17011000 | 18 x 20 x 2 mm; rechts und links verwendbar 18 x 20 x 2 mm; for right or left hand use |
| 17011100 | 24 x 22 x 2 mm; rechts und links verwendbar 24 x 22 x 2 mm; for right or left hand use |





Zubehör Brüstungsverglasung | accessories for balustrade glazing

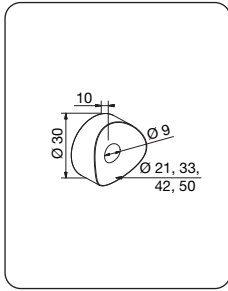
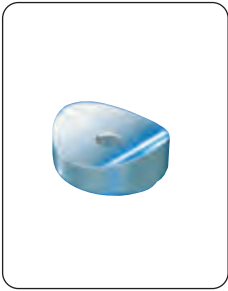

Art. Nr.: | item no.: 174869

Distanzstück für Rundrohr. Bitte Rundrohrdurchmesser angeben | spacer piece for round tube. Please specify round tube diameter

Material: Zinkdruckguss

Ø 21, 33, 42, 50

zu Artikel Nr. | for item no.
174860, 174866, 174870,
174871, 174872, 174873

Farbe | colour

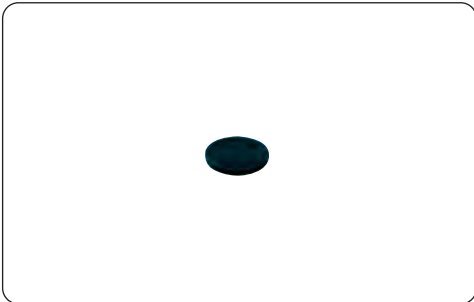

Art. Nr.: | item no.: 17011200

Ø 12 mm x 1 mm

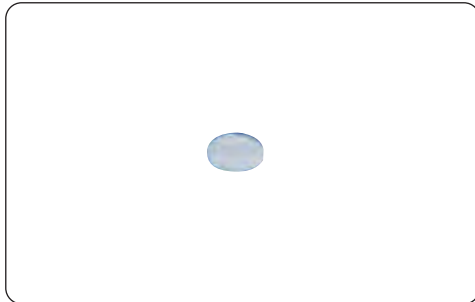

Art. Nr.: | item no.: 17011300

Kunststoffauflage selbstklebend, Ø 9 x 1,5 mm
self-adhesive plastic support, Ø 9 x 1,5 mm
passend zu | suitable for use with:
17011000; 17011100

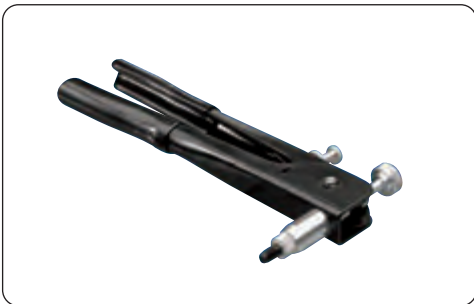

Art. Nr.: | item no.: 17011400

Blindnietmutternzange einschl. Gewindedorn M8
blind rivet nut pliers incl. thread tap M8

Art. Nr.: | item no.: 17011500

Gewindedorn M6 | thread tap M6



Art. Nr.: | item no.: 17011600

Blindnietmutter mit Senkbördelung und Schaft-
rändelung für M8-Gewindeschrauben. Nietbare
Materialstärke von 0,25 – 3 mm
blind rivet nut with countersunk beading and
knurled shank for M8 threaded screws. Rivetable
material thickness of 0,25 – 3 mm

Art. Nr.: | item no.: 17011700

Einnietmutter für M6-Gewindeschrauben
rivet nut for M6 threaded screws



Zubehör Brüstungsverglasung | accessories for balustrade glazing



Art. Nr.: | item no.: 17011800 | 17011900

Zylinderkopfschraube M10x45 (M10x60) nach DIN912 | cylinder head screw M10x45 (M10x60) according to DIN912

| | |
|----------|--------|
| 17011800 | M10X45 |
| 17011900 | M10X60 |



Art. Nr.: | item no.: 17012000 | 17012100

Senkkopfschraube M10x45 (M10x60) nach DIN7991 | countersink screw M10x45 (M10x60) according to DIN7991

| | |
|----------|--------|
| 17012000 | M10X45 |
| 17012100 | M10X60 |



Art. Nr.: | item no.: 17020300 | 17012300

Gewindestift M10 nach DIN913
set screw according to DIN913

| | |
|----------|--------|
| 17020300 | M10X40 |
| 17012300 | M10X60 |



Art. Nr.: | item no.: 17020000* | 17020100 | 17020600

Zylinderkopfschraube mit Innensechskant nach DIN6912 | cylinder head screw according to DIN6912

| | |
|----------|-------|
| 17020000 | M8x20 |
| 17020100 | M8x20 |
| 17020600 | M6x30 |



Art. Nr.: | item no.: 17020200

Zylinderkopfschraube mit Innensechskant nach DIN912, M8x20 zur Montage von 174831/32/36/37 cylinder head screw according to DIN912, M8x20 for 174831/32/36/37



Art. Nr.: | item no.: 17021500

Spezialsenkopf-Sicherheitsschraube M6x16, V2A, für Klemmbefestigungen, ähnlich DIN7991 special countersink tamper-resistant screw M6x16, V2A, for clamp fixtures, similar to DIN7991

INFO

Alle nicht gekennzeichneten Schrauben sind aus Edelstahl, Material: A2 (1.4301)
All unmarked screws are made of stainless steel, material: A2 (1.4301)

* Material Stahl verzinkt
* material steel zinc finish





Zubehör Brüstungsverglasung | accessories for balustrade glazing

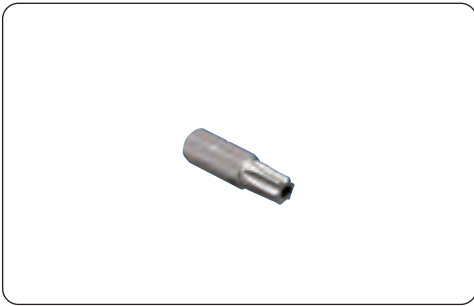

Art. Nr.: | item no.: 17021600

Spezial-Bit für Sicherheitsschrauben
zu Artikel Nr.: 17021500
special bit for tamper-resistant screws
for item no.: 17021500



Art. Nr.: | item no.: 17012700

Verstellbarer Stirnlochschlüssel 3 mm
adjustable face pin wrench 3 mm

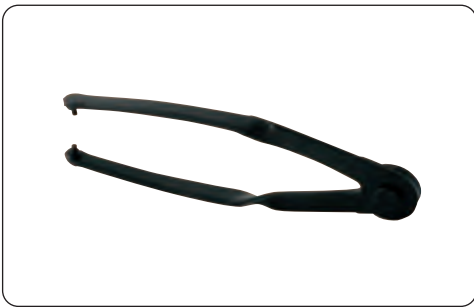

Art. Nr.: | item no.: 17012800

Verstellbarer Spezialschlüssel 3 mm
adjustable special wrench 3mm



Art. Nr.: | item no.: 17021400

Hakenschlüssel | hook wrench

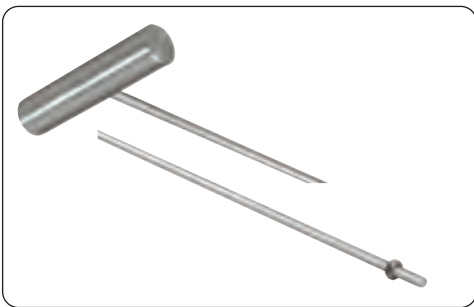

Art. Nr.: | item no.: 17013000

Montagehilfe für Banano Rundrohrbefestigung
assembly aid for Banano round tube fixture



Art. Nr.: | item no.: 80002300

Edelstahlpflege 500 ml
stainless steel treatment agent 500 ml



Pflegeprodukte Seite
treatment products 608-615
Pflegeinfo Seite | treatment
instructions 621-622

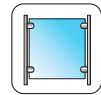
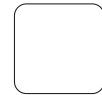

■ Inhalt | content

- Rundrohr | round tube 72
- Rundstab | round bar 73
- Quadratrohr | square tube 73

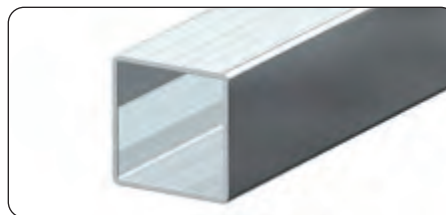

INFO

Alle Angaben in Millimeter.
 All dimensions in millimetres.
 The German decimal separator has been used for the measurements in the tables and graphs, i.e. 0,00 mm = 0.00 mm.



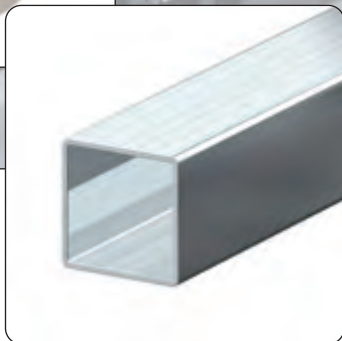

■ Rohre und Stäbe | tubes and bars



■ Rundrohr
round tube



INFO

Rohre sind auch in anderen Rohr-
dimensionen und Materialgüten auf
Anfrage lieferbar.
Tubes are also available in other dimen-
sions and material grades upon request.

| Art. Nr. item no. | Material material | Ø | Länge length | Oberfläche finish | |
|----------------------|----------------------|------------|-----------------|----------------------|---|
| 10 90 46 00 | V2A (1.4301) | 33,7 x 2,0 | 6000 | Korn finish 240 | 1 |
| 10 90 33 00 | V2A (1.4301) | 33,7 x 2,0 | 3000 | Korn finish 240 | 1 |
| 10 90 55 00 | V2A (1.4301) | 33,7 x 2,0 | 2000 | Korn finish 240 | 1 |
| 10 90 45 00 | V2A (1.4301) | 42,4 x 2,0 | 6000 | Korn finish 240 | 1 |
| 10 90 34 00 | V2A (1.4301) | 42,4 x 2,0 | 3000 | Korn finish 240 | 1 |
| 10 90 56 00 | V2A (1.4301) | 42,4 x 2,0 | 2000 | Korn finish 240 | 1 |
| 10 90 74 00 | V2A (1.4301) | 48,3 x 2,0 | 6000 | Korn finish 240 | 1 |
| 10 90 75 00 | V2A (1.4301) | 48,3 x 2,0 | 3000 | Korn finish 240 | 1 |
| 10 90 76 00 | V2A (1.4301) | 48,3 x 2,0 | 2000 | Korn finish 240 | 1 |
| 10 90 60 00 | V4A | 33,7 x 2,0 | 6000 | Korn finish 240 | 1 |
| 10 90 61 00 | V4A | 33,7 x 2,0 | 3000 | Korn finish 240 | 1 |
| 10 90 62 00 | V4A | 33,7 x 2,0 | 2000 | Korn finish 240 | 1 |
| 10 90 63 00 | V4A | 42,4 x 2,0 | 6000 | Korn finish 240 | 1 |
| 10 90 64 00 | V4A | 42,4 x 2,0 | 3000 | Korn finish 240 | 1 |
| 10 90 65 00 | V4A | 42,4 x 2,0 | 2000 | Korn finish 240 | 1 |
| 10 90 77 00 | V4A | 48,3 x 2,0 | 6000 | Korn finish 240 | 1 |
| 10 90 78 00 | V4A | 48,3 x 2,0 | 3000 | Korn finish 240 | 1 |
| 10 90 79 00 | V4A | 48,3 x 2,0 | 2000 | Korn finish 240 | 1 |

☺ ≡ 24h
☺ ≡ 24h
☺ ≡ 24h
☺ ≡ 24h
☺ ≡ 24h
☺ ≡ 24h
☺ ≡ 24h
☺ ≡ 24h
☺ ≡ 24h



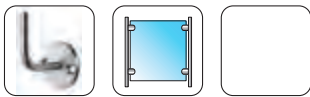

■ Rundstab
round bar



INFO

Stäbe sind auch in anderen Stabdurchmessern und Materialgüten auf Anfrage lieferbar.
Bars are also available in other dimensions and material grades upon request.

| Art. Nr. item no. | Material material | Ø | Länge length | Oberfläche finish | |
|----------------------|----------------------|----|-----------------|----------------------|---|
| 10 90 52 00 | V2A (1.4301) | 10 | 6000 | roh raw | 1 |
| 10 90 31 00 | V2A (1.4301) | 10 | 3000 | roh raw | 1 |
| 10 90 53 00 | V2A (1.4301) | 10 | 2000 | roh raw | 1 |
| 10 90 47 00 | V2A (1.4301) | 12 | 6000 | roh raw | 1 |
| 10 90 32 00 | V2A (1.4301) | 12 | 3000 | roh raw | 1 |
| 10 90 54 00 | V2A (1.4301) | 12 | 2000 | roh raw | 1 |
| 10 90 66 00 | V4A | 10 | 6000 | roh raw | 1 |
| 10 90 67 00 | V4A | 10 | 3000 | roh raw | 1 |
| 10 90 68 00 | V4A | 10 | 2000 | roh raw | 1 |
| 10 90 69 00 | V4A | 12 | 6000 | roh raw | 1 |
| 10 90 70 00 | V4A | 12 | 3000 | roh raw | 1 |
| 10 90 71 00 | V4A | 12 | 2000 | roh raw | 1 |

24h
 24h
 24h
 24h
 24h
 24h

■ Quadratrohr
square tube



INFO

Rohre sind auch in anderen Rohrdimensionen und Materialgüten auf Anfrage lieferbar.
Tubes are also available in other dimensions and material grades upon request.

| Art. Nr. item no. | Material material | | Länge length | Oberfläche finish | |
|----------------------|----------------------|---------------|-----------------|----------------------|---|
| 10 90 57 00 | V2A (1.4301) | 30 x 30 x 2,0 | 3000 | Korn finish 240 | 1 |
| 10 90 58 00 | V2A (1.4301) | 40 x 40 x 2,0 | 3000 | Korn finish 240 | 1 |
| 10 90 72 00 | V4A | 30 x 30 x 2,0 | 3000 | Korn finish 240 | 1 |
| 10 90 73 00 | V4A | 40 x 40 x 2,0 | 3000 | Korn finish 240 | 1 |

24h
 24h

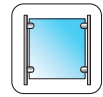
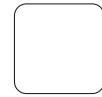

■ Inhalt | content

- Endkappen | end caps76
- Anschweißdeckel | weldings caps79





■ Endkappen und Anschweißdeckel
end caps and weldings caps



■ Endkappe flach, hohl
end cap flat, hollow

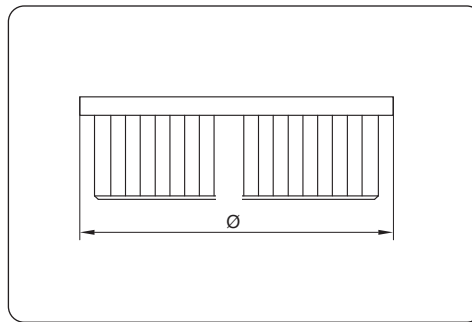

| Art. Nr. item no. | Material material | Rohr Ø tube Ø | Oberfläche finish | |
|----------------------|----------------------|------------------|----------------------|---|
| 10 00 39 00 | V2A (1.4301) | 33,7 x 2,0 | Korn finish 240 | 2 |
| 10 00 40 00 | V2A (1.4301) | 42,4 x 2,0 | Korn finish 240 | 2 |
| 10 55 54 00 | V4A | 33,7 x 2,0 | Korn finish 240 | 2 |
| 10 55 55 00 | V4A | 42,4 x 2,0 | Korn finish 240 | 2 |

■ Endkappe flach, massiv
end cap flat, solid

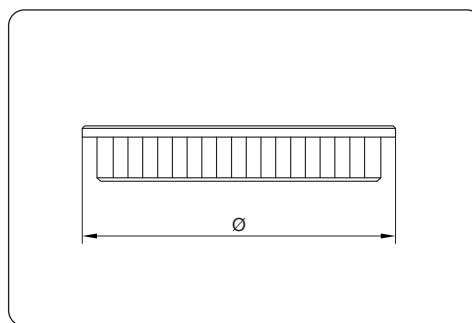

| Art. Nr. item no. | Material material | Rohr Ø tube Ø | Oberfläche finish | |
|----------------------|----------------------|------------------|----------------------|---|
| 10 00 02 00 | V2A (1.4301) | 26,9 x 2,0 | Korn finish 240 | 2 |
| 10 00 03 00 | V2A (1.4301) | 33,7 x 2,0 | Korn finish 240 | 2 |
| 10 00 04 00 | V2A (1.4301) | 42,4 x 2,0 | Korn finish 240 | 2 |
| 10 00 06 00 | V2A (1.4301) | 48,3 x 2,0 | Korn finish 240 | 2 |
| 10 55 08 00 | V4A | 33,7 x 2,0 | Korn finish 240 | 2 |
| 10 55 09 00 | V4A | 42,4 x 2,0 | Korn finish 240 | 2 |





■ Endkappe oval, hohl
end cap oval, hollow

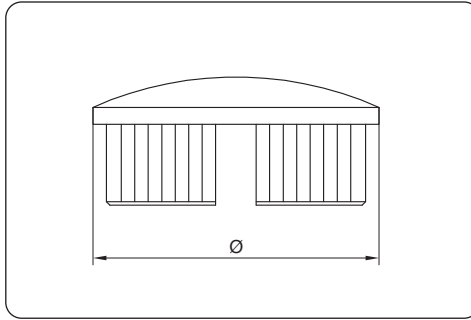

| Art. Nr. item no. | Material material | Rohr Ø tube Ø | Oberfläche finish | |
|----------------------|----------------------|------------------|----------------------|---|
| 10 00 31 00 | V2A (1.4301) | 33,7 x 2,0 | Korn finish 240 | 2 |
| 10 00 30 00 | V2A (1.4301) | 42,4 x 2,0 | Korn finish 240 | 2 |
| 10 00 44 00 | V4A | 33,7 x 2,0 | Korn finish 240 | 2 |
| 10 00 33 00 | V4A | 42,4 x 2,0 | Korn finish 240 | 2 |

■ Endkappe oval, massiv
end cap oval, solid

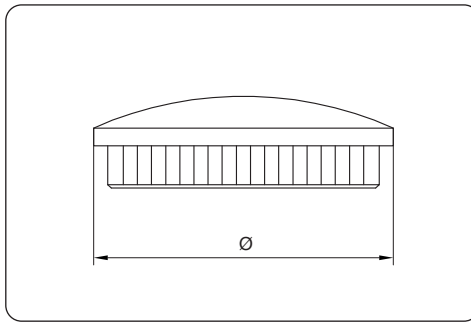

| Art. Nr. item no. | Material material | Rohr Ø tube Ø | Oberfläche finish | |
|----------------------|----------------------|------------------|----------------------|---|
| 10 00 07 00 | V2A (1.4301) | 26,9 x 2,0 | Korn finish 240 | 2 |
| 10 00 08 00 | V2A (1.4301) | 33,7 x 2,0 | Korn finish 240 | 2 |
| 10 00 09 00 | V2A (1.4301) | 42,4 x 2,0 | Korn finish 240 | 2 |
| 10 00 11 00 | V2A (1.4301) | 48,3 x 2,0 | Korn finish 240 | 2 |
| 10 55 10 00 | V4A | 33,7 x 2,0 | Korn finish 240 | 2 |
| 10 55 11 00 | V4A | 42,4 x 2,0 | Korn finish 240 | 2 |



- Endkappe rund, massiv
end cap round, solid

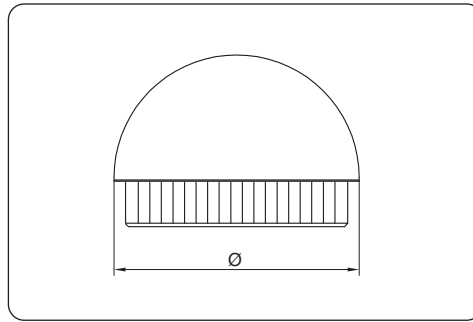

| Art. Nr. item no. | Material material | Rohr Ø tube Ø | Oberfläche finish | |
|----------------------|----------------------|------------------|----------------------|---|
| 10 00 12 00 | V2A (1.4301) | 26,9 x 2,0 | Korn finish 240 | 2 |
| 10 00 13 00 | V2A (1.4301) | 33,7 x 2,0 | Korn finish 240 | 2 |
| 10 00 14 00 | V2A (1.4301) | 42,4 x 2,0 | Korn finish 240 | 2 |
| 10 00 16 00 | V2A (1.4301) | 48,3 x 2,0 | Korn finish 240 | 2 |

- Endkappe oval flexibel, hohl
end cap oval, flexible, hollow

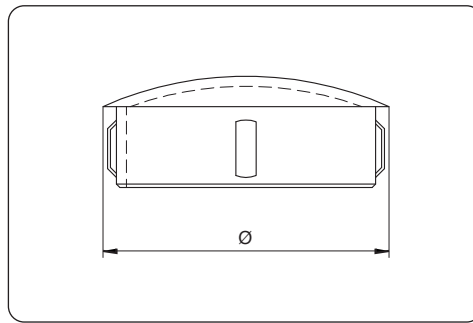

| Art. Nr. item no. | Material material | Rohr Ø tube Ø | Oberfläche finish | |
|----------------------|----------------------|------------------|----------------------|---|
| 10 00 20 00 | V4A | 33,7 x 1,5 - 2,6 | Korn finish 240 | 2 |
| 10 00 21 00 | V4A | 42,4 x 1,5 - 2,6 | Korn finish 240 | 2 |
| 10 00 28 00 | V4A | 48,3 x 2,0 - 2,6 | Korn finish 240 | 2 |





- Endkappe oval mit Lamelle, massiv
end cap oval with fin, solid

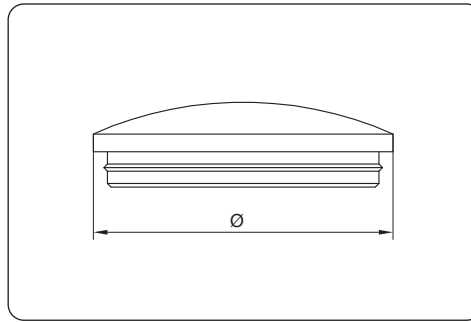

| Art. Nr. item no. | Material material | Rohr Ø tube Ø | Oberfläche finish | |
|----------------------|----------------------|------------------|----------------------|---|
| 10 00 00 00 | V2A (1.4301) | 33,7 x 2,0 | Korn finish 240 | 2 |
| 10 00 01 00 | V2A (1.4301) | 42,4 x 2,0 | Korn finish 240 | 2 |
| 10 00 35 00 | V2A (1.4301) | 42,4 x 2,6 | Korn finish 240 | 2 |

- Anschweißdeckel oval
end cap for welding oval

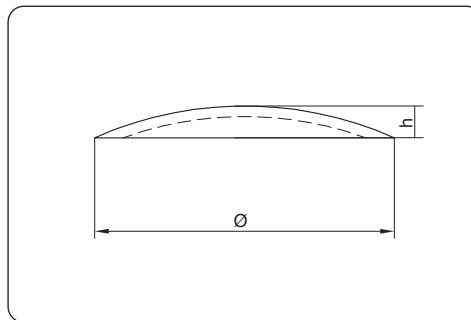

| Art. Nr. item no. | Material material | Rohr Ø tube Ø | h | Oberfläche finish | |
|----------------------|----------------------|------------------|-----|----------------------|---|
| 10 90 03 00 | V2A (1.4301) | 33,7 | 1,5 | roh raw | 4 |
| 10 90 04 00 | V2A (1.4301) | 42,4 | 1,5 | roh raw | 4 |
| 10 90 05 00 | V2A (1.4301) | 48,3 | 1,5 | roh raw | 4 |
| 10 90 06 00 | V2A (1.4301) | 60,3 | 2,5 | roh raw | 4 |

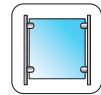

■ Inhalt | content

- Handlaufträger | handrail supports 82
- Handlaufträger mit Glasanschluss 90
handrails support with glass connector
- Zubehör für Handlaufträger | accessories for handrail supports 91





■ Handlaufträger und Zubehör
handrail supports and accessories

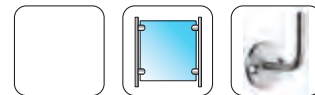

■ Handlaufträger mit Rundstab
handrail support with round bar

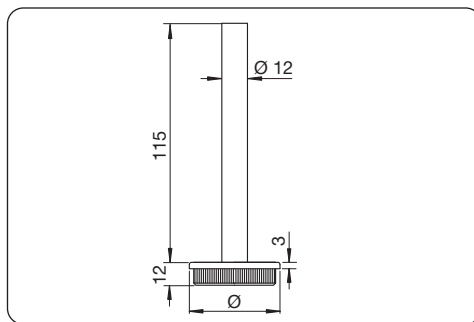

| Art. Nr. item no. | Material material | Rohr Ø tube Ø | Oberfläche finish | |
|----------------------|----------------------|------------------|----------------------|---|
| 10 10 15 00 | V2A (1.4301) | 33,7 x 2,0 | Korn finish 240 | 2 |
| 10 10 00 00 | V2A (1.4301) | 42,4 x 2,0 | Korn finish 240 | 2 |

■ Handlaufträger mit Rundstab
handrail support with round bar

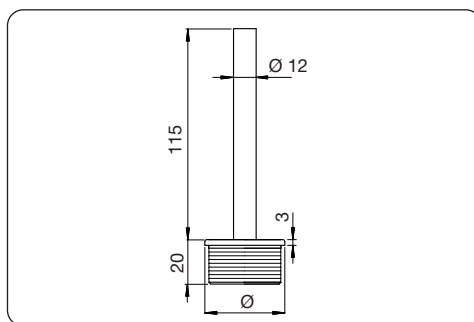

| Art. Nr. item no. | Material material | Rohr Ø tube Ø | Oberfläche finish | |
|----------------------|----------------------|------------------|----------------------|---|
| 10 10 01 00 | V2A (1.4301) | 42,4 x 2,0 | Korn finish 240 | 2 |
| 10 10 02 00 | V2A (1.4301) | 42,4 x 2,6 | Korn finish 240 | 2 |





■ Handlaufträger starr, hohl
handrail support rigid, hollow

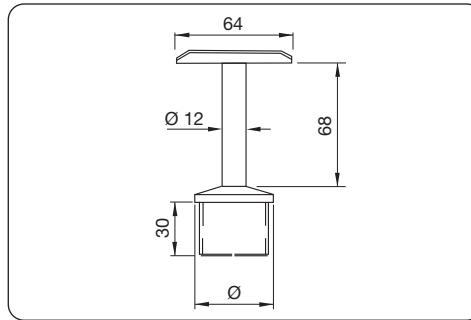

| Art. Nr. item no. | Material material | Rohr Ø tube Ø | Aufnahme adapter | Oberfläche finish | |
|----------------------|----------------------|------------------|---------------------|----------------------|---|
| 10 30 93 00 | V2A (1.4301) | 33,7 x 2,0 | 33,7 - 42,4 | Korn finish 240 | 2 |
| 10 30 94 00 | V2A (1.4301) | 42,4 x 2,0 | 33,7 - 42,4 | Korn finish 240 | 2 |
| 10 31 28 00 | V4A | 33,7 x 2,0 | 33,7 - 42,4 | Korn finish 240 | 2 |
| 10 31 27 00 | V4A | 42,4 x 2,0 | 33,7 - 42,4 | Korn finish 240 | 2 |

■ Handlaufträger starr, massiv
handrail support rigid, solid

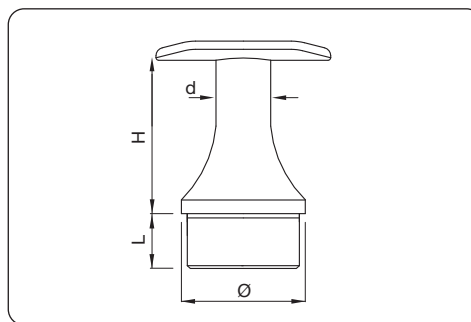

| Art. Nr. item no. | Material material | Rohr Ø tube Ø | d | L | H | Aufnahme adapter | Oberfläche finish | |
|----------------------|----------------------|------------------|----|----|----|---------------------|----------------------|---|
| 10 10 20 00 | V2A (1.4301) | 33,7 x 2,0 | 14 | 12 | 49 | 33,7 - 42,4 | Korn finish 240 | 2 |
| 10 10 25 00 | V2A (1.4301) | 42,4 x 2,0 | 20 | 10 | 58 | 33,7 - 42,4 | Korn finish 240 | 2 |

■ Handlaufträger für seitliche Montage
handrail support for side mounting

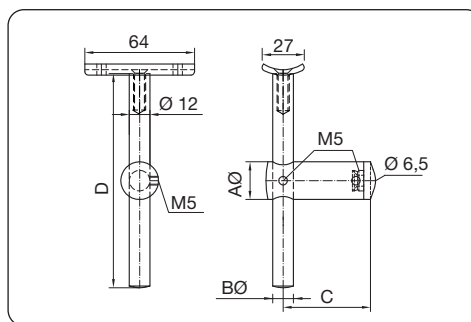

| Art. Nr. item no. | Material material | Rohr Ø tube Ø | AØ | BØ | C | D | Aufnahme adapter | Oberfläche finish | |
|----------------------|----------------------|------------------|----|----|----|-----|---------------------|----------------------|---|
| 10 10 16 00 | V2A (1.4301) | 42,4 | 22 | 12 | 51 | 125 | 33,7 - 42,4 | Korn finish 240 | 2 |
| 10 10 32 00 | V2A (1.4301) | 42,4 | 24 | 14 | 80 | 100 | 33,7 - 42,4 | Korn finish 240 | 2 |

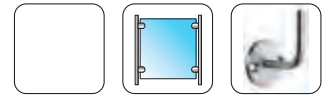

■ Handlaufträger für seitliche Montage, variabel
handrail support for side mounting, variable

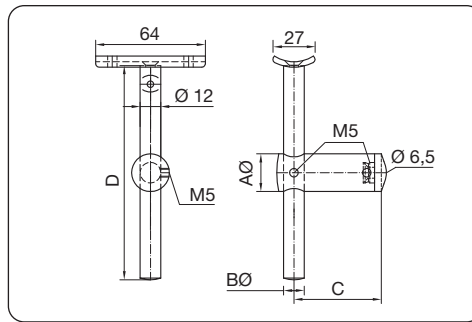

| Art. Nr. item no. | Material material | Rohr Ø tube Ø | AØ | BØ | C | D | Aufnahme adapter | Oberfläche finish | |
|----------------------|----------------------|------------------|----|----|----|-----|---------------------|----------------------|---|
| 10 10 31 00 | V2A (1.4301) | 42,4 | 24 | 14 | 80 | 100 | 33,7 - 42,4 | Korn finish 240 | 2 |

■ Handlaufträger variabel, hohl
handrail support variable, hollow

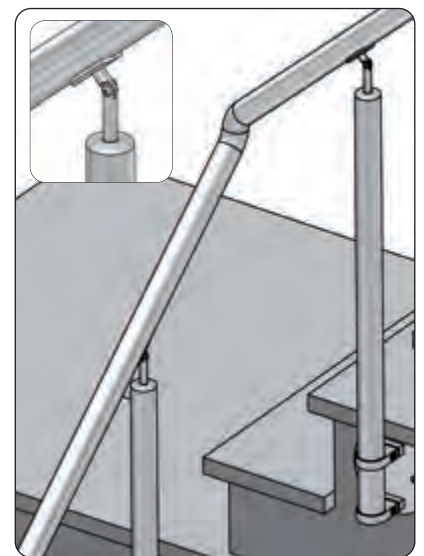
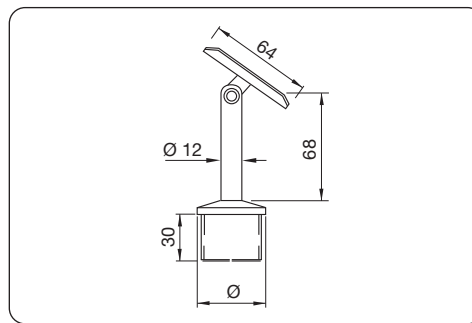

| Art. Nr. item no. | Material material | Rohr Ø tube Ø | Aufnahme adapter | Oberfläche finish | |
|----------------------|----------------------|------------------|---------------------|----------------------|---|
| 10 30 96 00 | V2A (1.4301) | 33,7 x 2,0 | 33,7 - 42,4 | Korn finish 240 | 2 |
| 10 30 95 00 | V2A (1.4301) | 42,4 x 2,0 | 33,7 - 42,4 | Korn finish 240 | 2 |
| 10 31 22 00 | V4A | 33,7 x 2,0 | 33,7 - 42,4 | Korn finish 240 | 2 |
| 10 31 21 00 | V4A | 42,4 x 2,0 | 33,7 - 42,4 | Korn finish 240 | 2 |

■ Handlaufträger variabel, massiv
handrail support variable, solid

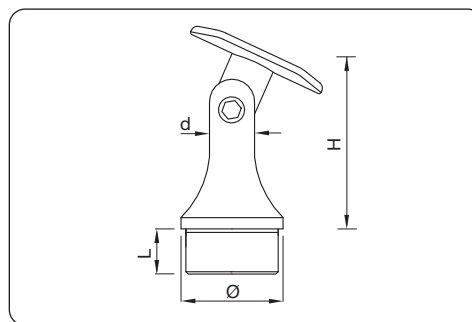

| Art. Nr. item no. | Material material | Rohr Ø tube Ø | d | H | L | Aufnahme adapter | Oberfläche finish | |
|----------------------|----------------------|------------------|----|----|----|---------------------|----------------------|---|
| 10 10 19 00 | V2A (1.4301) | 33,7 x 2,0 | 14 | 49 | 12 | 33,7 - 42,4 | Korn finish 240 | 2 |
| 10 10 03 00 | V2A (1.4301) | 42,4 x 2,0 | 20 | 49 | 15 | 33,7 - 42,4 | Korn finish 240 | 2 |





■ Handlaufträger starr, gekröpft
handrail support rigid, offset

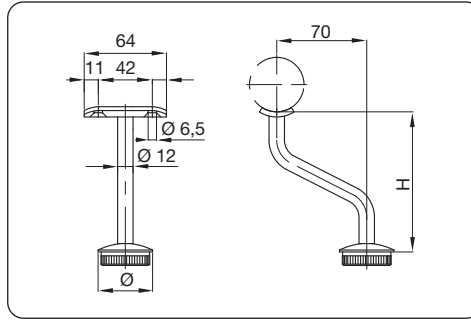

| Art. Nr. item no. | Material material | Rohr Ø tube Ø | H | Aufnahme adapter | Oberfläche finish | |
|----------------------|----------------------|------------------|-----|---------------------|----------------------|---|
| 10 10 45 00 | V2A (1.4301) | 33,7 x 2,0 | 110 | 33,7 - 42,4 | Korn finish 240 | 2 |
| 10 10 46 00 | V2A (1.4301) | 42,4 x 2,0 | 110 | 33,7 - 42,4 | Korn finish 240 | 2 |
| 10 55 72 00 | V4A | 33,7 x 2,0 | 110 | 33,7 - 42,4 | Korn finish 240 | 2 |
| 10 55 73 00 | V4A | 42,4 x 2,0 | 110 | 33,7 - 42,4 | Korn finish 240 | 2 |

■ Handlaufträger variabel, gekröpft
handrail support variable, offset

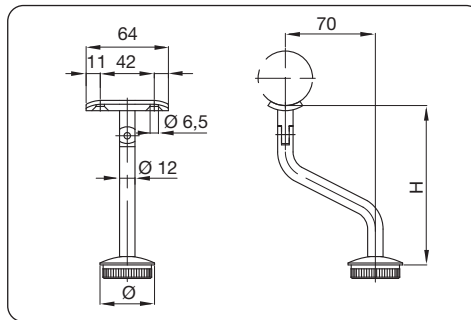

| Art. Nr. item no. | Material material | Rohr Ø tube Ø | H | Aufnahme adapter | Oberfläche finish | |
|----------------------|----------------------|------------------|-----|---------------------|----------------------|---|
| 10 10 43 00 | V2A (1.4301) | 33,7 x 2,0 | 125 | 33,7 - 42,4 | Korn finish 240 | 2 |
| 10 10 44 00 | V2A (1.4301) | 42,4 x 2,0 | 125 | 33,7 - 42,4 | Korn finish 240 | 2 |
| 10 55 70 00 | V4A | 33,7 x 2,0 | 125 | 33,7 - 42,4 | Korn finish 240 | 2 |
| 10 55 71 00 | V4A | 42,4 x 2,0 | 125 | 33,7 - 42,4 | Korn finish 240 | 2 |

■ Handlaufträger mit Kugelring, höhenverstellbar mit Doppelgelenk
handrail support with ball ring, height adjustable with double joint

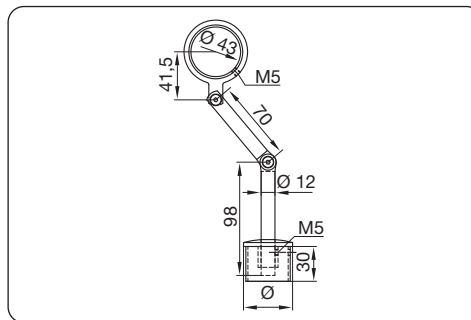

| Art. Nr. item no. | Material material | Rohr Ø tube Ø | Aufnahme adapter | Oberfläche finish | |
|----------------------|----------------------|------------------|---------------------|----------------------|---|
| 10 30 98 00 | V2A (1.4301) | 42,4 x 2,0 | 42,4 mm | Korn finish 240 | 2 |



■ Handlaufträger zum Anschweißen
handrail support for welding

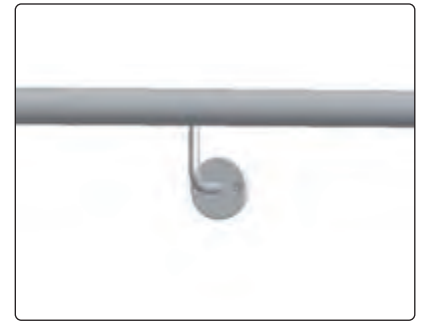
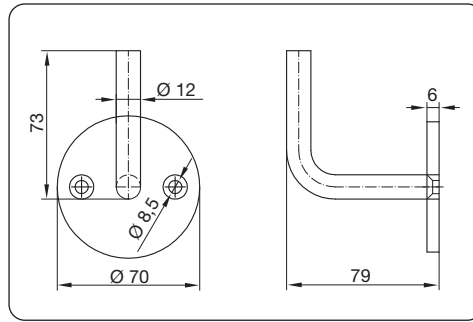

| Art. Nr. item no. | Material material | Oberfläche finish | |
|----------------------|----------------------|----------------------|---|
| 10 10 38 00 | V2A (1.4301) | Korn finish 240 | 2 |

■ Handlaufträger zum Anschweißen
handrail support for welding

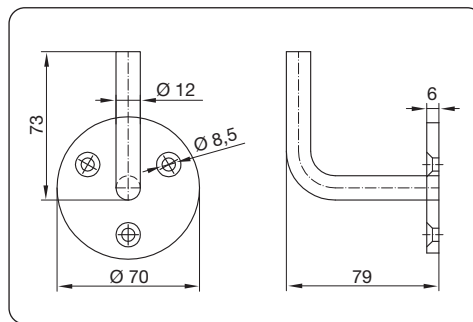

| Art. Nr. item no. | Material material | Oberfläche finish | |
|----------------------|----------------------|----------------------|---|
| 10 10 13 00 | V2A (1.4301) | Korn finish 240 | 2 |

■ Handlaufträger variabel
handrail support variable

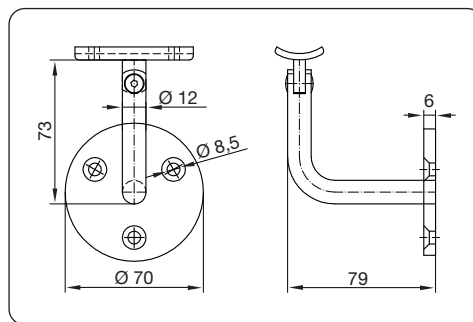

| Art. Nr. item no. | Material material | Aufnahme adapter | Oberfläche finish | |
|----------------------|----------------------|---------------------|----------------------|---|
| 10 10 11 00 | V2A (1.4301) | 33,7 - 42,4 | Korn finish 240 | 2 |





■ Handlaufträger mit Innengewinde
handrail support with internal thread

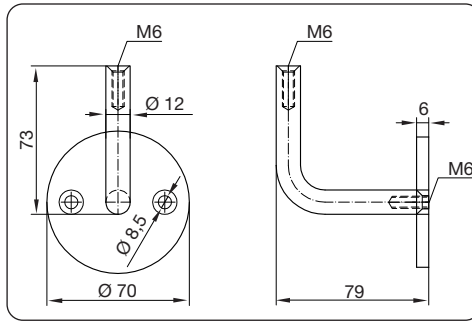

| Art. Nr. item no. | Material material | Oberfläche finish | |
|----------------------|----------------------|----------------------|---|
| 10 00 27 00 | V2A (1.4301) | Korn finish 240 | 2 |
| 10 56 15 00 | V4A | Korn finish 240 | 2 |

■ Handlaufträger mit Innengewinde
handrail support with internal thread

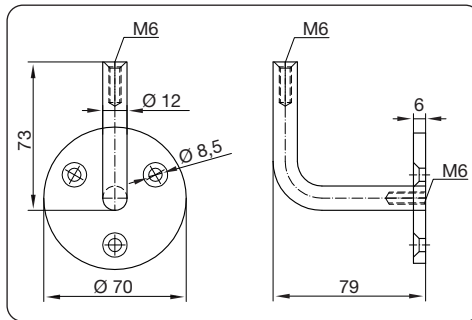

| Art. Nr. item no. | Material material | Oberfläche finish | |
|----------------------|----------------------|----------------------|---|
| 10 10 39 00 | V2A (1.4301) | Korn finish 240 | 2 |

■ Handlaufträger starr, gelasert
handrail support rigid, laser cut

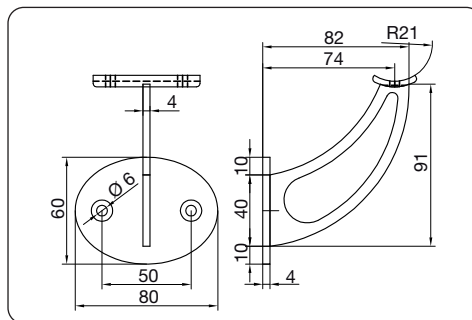

| Art. Nr. item no. | Material material | Aufnahme adapter | Oberfläche finish | |
|----------------------|----------------------|---------------------|----------------------|---|
| 10 10 37 00 | V2A (1.4301) | 33,7 - 42,4 | Korn finish 240 | 2 |



■ Handlaufträger mit Innengewinde für Stockschraube
handrail support with internal thread for hanger bolt

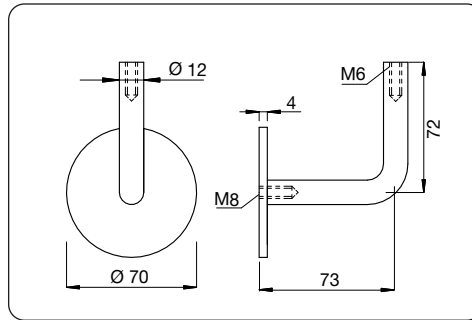

| Art. Nr. item no. | Material material | | Oberfläche finish | |
|----------------------|----------------------|-------|----------------------|---|
| 10 00 26 00 | V2A (1.4301) | M6/M8 | Korn finish 240 | 2 |

■ Handlaufträger zum Einkleben
handrail supports for gluing

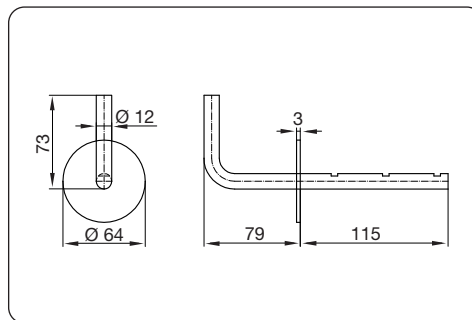

| Art. Nr. item no. | Material material | Oberfläche finish | |
|----------------------|----------------------|----------------------|---|
| 10 10 34 00 | V2A (1.4301) | Korn finish 240 | 2 |

INFO

Zubehör | accessories
Art. Nr. 13 90 68 00
Verbundmörtel Seite 614
compound mortar page 614

■ Handlaufträger zum Einkleben
handrail supports for gluing

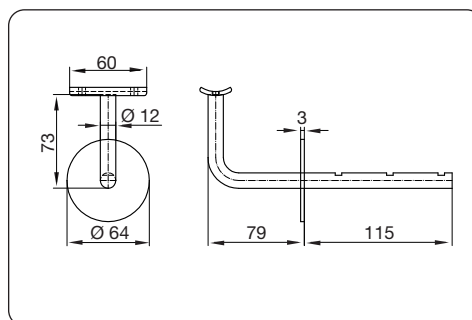

| Art. Nr. item no. | Material material | Aufnahme adapter | Oberfläche finish | |
|----------------------|----------------------|---------------------|----------------------|---|
| 10 10 33 00 | V2A (1.4301) | 33,7 - 42,4 | Korn finish 240 | 2 |





■ Handlaufträger zum Einkleben
handrail supports for glueing

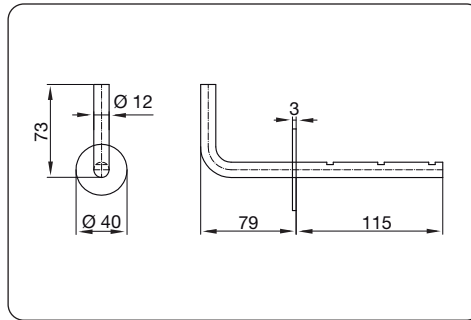

| Art. Nr. item no. | Material material | Oberfläche finish | |
|----------------------|----------------------|----------------------|---|
| 10 10 36 00 | V2A (1.4301) | Korn finish 240 | 2 |

■ Handlaufträger zum Einkleben
handrail supports for glueing

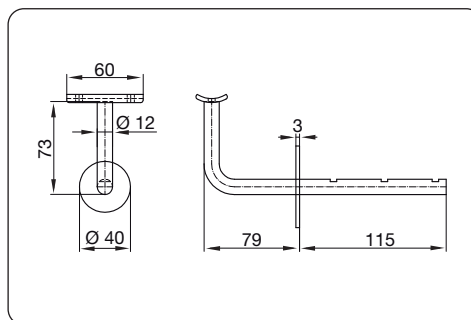

| Art. Nr. item no. | Material material | Aufnahme adapter | Oberfläche finish | |
|----------------------|----------------------|---------------------|----------------------|---|
| 10 10 35 00 | V2A (1.4301) | 33,7 - 42,4 | Korn finish 240 | 2 |

■ Handlaufträger
handrail supports

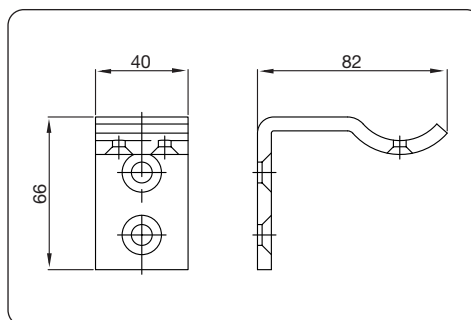

| Art. Nr. item no. | Material material | Aufnahme adapter | Oberfläche finish | |
|----------------------|----------------------|---------------------|----------------------|---|
| 10 10 40 00 | V2A (1.4301) | 33,7 - 42,4 | Korn finish 240 | 2 |
| 10 55 67 00 | V4A | 33,7 - 42,4 | Korn finish 240 | 2 |



- Handlaufträger höhenverstellbar mit Glasanschluss
handrail support height adjustable, with glass connector

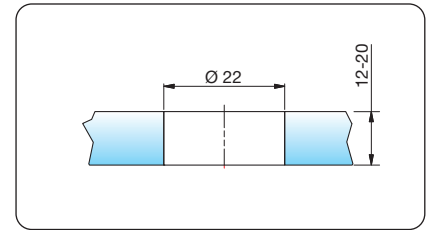
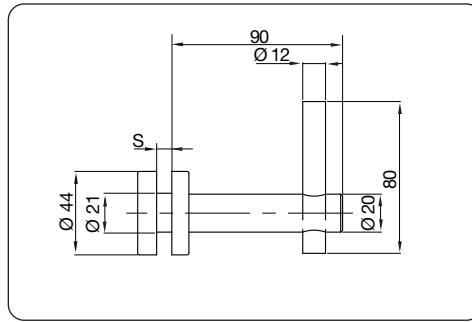
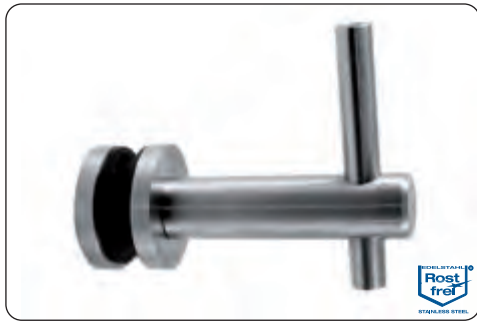

| Art. Nr. item no. | Material material | S | Oberfläche finish | |
|----------------------|----------------------|--------|----------------------|---|
| 10 10 42 00 | V2A (1.4301) | 8 - 25 | Korn finish 240 | 2 |
| 10 55 69 00 | V4A | 8 - 25 | Korn finish 240 | 2 |

- Handlaufträger starr mit Glasanschluss
handrail support rigid, with glass connector

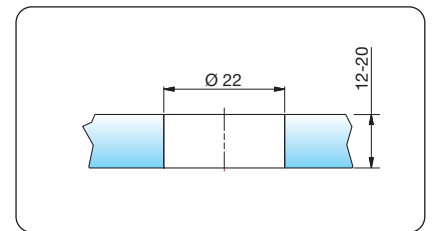
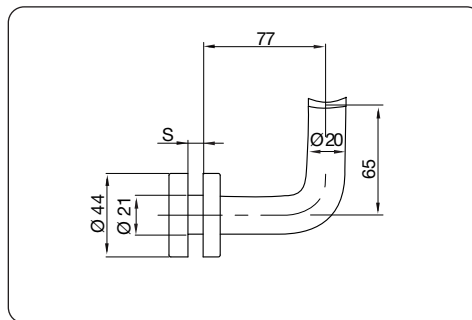

| Art. Nr. item no. | Material material | Aufnahme adapter | S | Oberfläche finish | |
|----------------------|----------------------|---------------------|--------|----------------------|---|
| 10 10 41 00 | V2A (1.4301) | 33,7 - 42,4 | 8 - 25 | Korn finish 240 | 2 |
| 10 55 68 00 | V4A | 33,7 - 42,4 | 8 - 25 | Korn finish 240 | 2 |

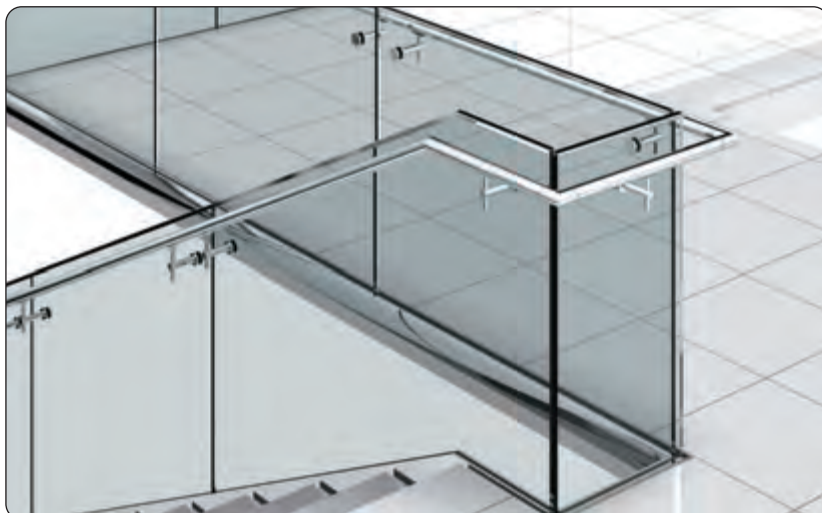



■ Abdeckkrosette
cover plate

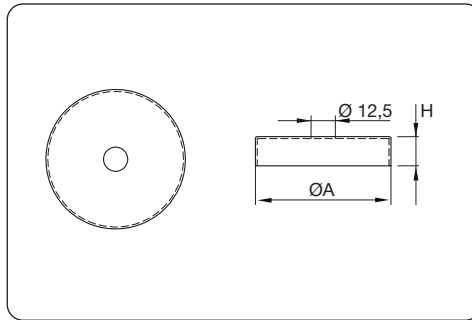

| Art. Nr. item no. | Material material | ØA | H | Oberfläche finish | |
|----------------------|----------------------|----|----|----------------------|---|
| 10 20 05 00 | V2A (1.4301) | 45 | 10 | Korn finish 240 | 2 |
| 10 20 00 00 | V2A (1.4301) | 70 | 12 | Korn finish 240 | 2 |
| 10 20 07 00 | V2A (1.4301) | 76 | 12 | Korn finish 240 | 2 |
| 10 55 49 00 | V4A | 76 | 12 | Korn finish 240 | 2 |

■ Kugelring
ball ring

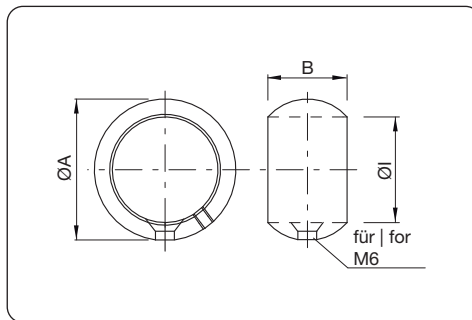

| Art. Nr. item no. | Material material | B | ØA | ØI | Oberfläche finish | |
|----------------------|----------------------|------|----|------|----------------------|---|
| 10 90 42 00 | V2A (1.4301) | 29,5 | 45 | 33,8 | Korn finish 240 | 2 |
| 10 90 43 00 | V2A (1.4301) | 29,5 | 55 | 42,5 | Korn finish 240 | 2 |
| 10 90 50 00 | V4A | 29,5 | 45 | 33,8 | Korn finish 240 | 2 |
| 10 90 51 00 | V4A | 29,5 | 55 | 42,5 | Korn finish 240 | 2 |



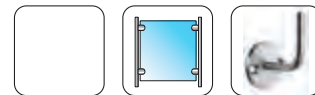

- Endkappe flach mit Innengewinde, hohl
end cap flat, with internal thread, hollow

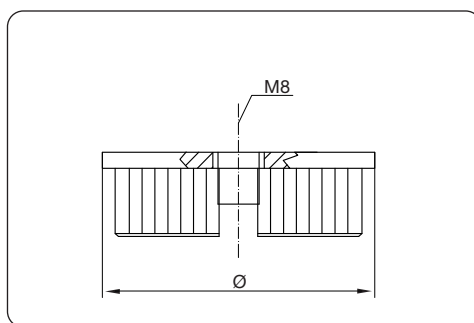

| Art. Nr. item no. | Material material | Ø | Oberfläche finish | |
|----------------------|----------------------|------------|----------------------|---|
| 10 00 41 00 | V2A (1.4301) | 33,7 x 2,0 | Korn finish 240 | 2 |
| 10 00 42 00 | V2A (1.4301) | 42,4 x 2,0 | Korn finish 240 | 2 |
| 10 55 52 00 | V4A | 33,7 x 2,0 | Korn finish 240 | 2 |
| 10 55 53 00 | V4A | 42,4 x 2,0 | Korn finish 240 | 2 |

- Endkappe flach mit Innengewinde, massiv
end cap flat, with internal thread, solid

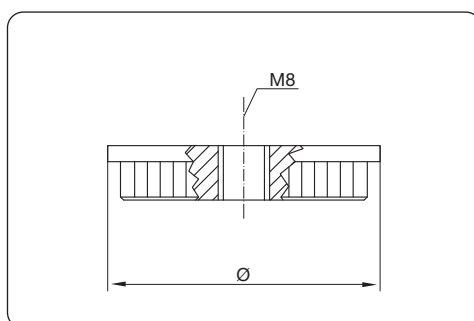

| Art. Nr. item no. | Material material | Ø | Oberfläche finish | |
|----------------------|----------------------|------------|----------------------|---|
| 10 00 22 00 | V2A (1.4301) | 33,7 x 2,0 | Korn finish 240 | 2 |
| 10 00 23 00 | V2A (1.4301) | 42,4 x 2,0 | Korn finish 240 | 2 |
| 10 55 04 00 | V4A | 33,7 x 2,0 | Korn finish 240 | 2 |
| 10 55 05 00 | V4A | 42,4 x 2,0 | Korn finish 240 | 2 |





- Endkappe oval mit Innengewinde, hohl
end cap oval, with internal thread, hollow

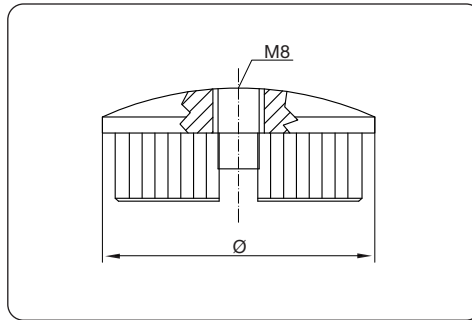

| Art. Nr. item no. | Material material | Ø | Oberfläche finish | |
|----------------------|----------------------|------------|----------------------|---|
| 10 00 43 00 | V2A (1.4301) | 33,7 x 2,0 | Korn finish 240 | 2 |
| 10 00 32 00 | V2A (1.4301) | 42,4 x 2,0 | Korn finish 240 | 2 |
| 10 00 45 00 | V4A | 33,7 x 2,0 | Korn finish 240 | 2 |
| 10 00 34 00 | V4A | 42,4 x 2,0 | Korn finish 240 | 2 |

- Endkappe oval mit Innengewinde, massiv
end cap oval, with internal thread, solid

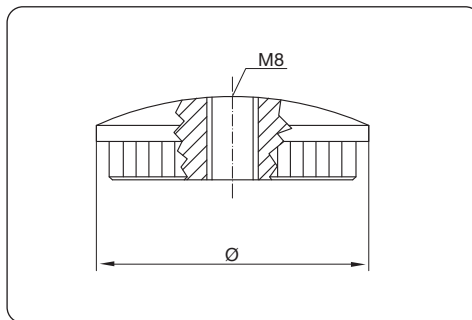

| Art. Nr. item no. | Material material | Ø | Oberfläche finish | |
|----------------------|----------------------|------------|----------------------|---|
| 10 00 24 00 | V2A (1.4301) | 33,7 x 2,0 | Korn finish 240 | 2 |
| 10 00 25 00 | V2A (1.4301) | 42,4 x 2,0 | Korn finish 240 | 2 |
| 10 00 36 00* | V2A (1.4301) | 42,4 x 2,6 | Korn finish 240 | 2 |
| 10 55 06 00 | V4A | 33,7 x 2,0 | Korn finish 240 | 2 |
| 10 55 07 00 | V4A | 42,4 x 2,0 | Korn finish 240 | 2 |

*mit Lamelle | with fins





- Endkappe mit Durchgangsbohrung, variabel höhenverstellbar
end cap with through hole, variable height adjustable

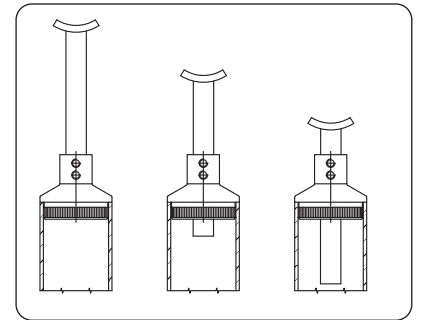
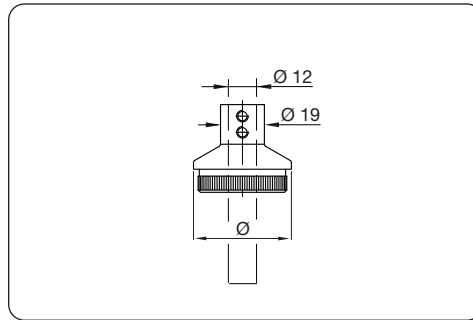

| Art. Nr. item no. | Material material | Rohr Ø tube Ø | Oberfläche finish | |
|----------------------|----------------------|------------------|----------------------|---|
| 10 00 46 00 | V2A (1.4301) | 33,7 x 2,0 | Korn finish 240 | 2 |
| 10 00 47 00 | V2A (1.4301) | 42,4 x 2,0 | Korn finish 240 | 2 |
| 10 55 56 00 | V4A | 33,7 x 2,0 | Korn finish 240 | 2 |
| 10 55 57 00 | V4A | 42,4 x 2,0 | Korn finish 240 | 2 |

- Handlaufträger mit Innengewinde
handrail support with internal thread

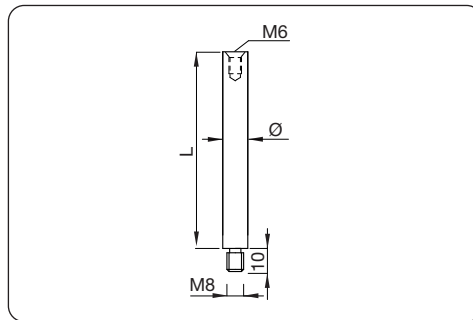

| Art. Nr. item no. | Material material | Ø | L | Oberfläche finish | |
|----------------------|----------------------|----|-----|----------------------|---|
| 10 90 18 00 | V2A (1.4301) | 12 | 68 | Korn finish 240 | 2 |
| 10 90 19 00 | V2A (1.4301) | 12 | 115 | Korn finish 240 | 2 |
| 10 90 44 00 | V2A (1.4301) | 14 | 65 | Korn finish 240 | 2 |
| 10 55 03 00 | V4A | 12 | 65 | Korn finish 240 | 2 |





■ Handlaufträger zum Anschweißen
handrail support for welding

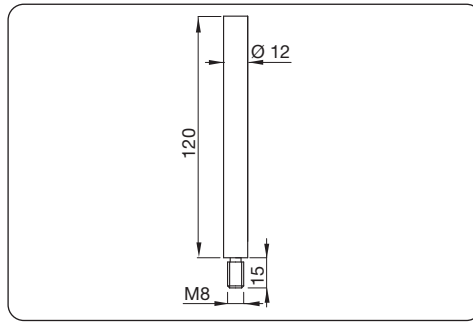

| Art. Nr. item no. | Material material | Oberfläche finish | |
|----------------------|----------------------|----------------------|---|
| 10 90 02 00 | V2A (1.4301) | Korn finish 240 | 2 |

■ Aufschubstück
weld socket

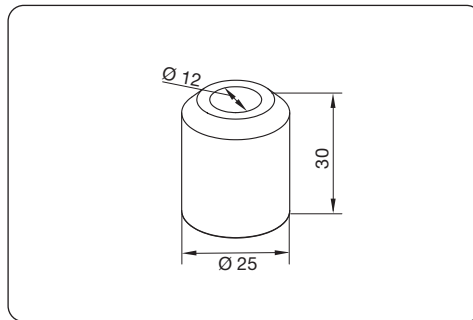

| Art. Nr. item no. | Material material | Oberfläche finish | |
|----------------------|----------------------|----------------------|---|
| 10 90 22 00 | V2A (1.4301) | Korn finish 240 | 2 |

Pflegeprodukte Seite
treatment products 608-615
Pflegeinfo Seite | treatment
instructions 621-622



Handlaufträger mit Gelenk und Innengewinde
handrail support with joint and internal thread

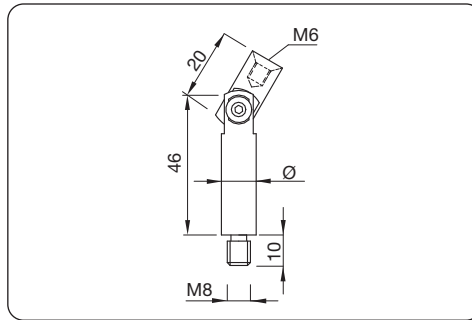

| Art. Nr. item no. | Material material | Ø | Oberfläche finish | |
|----------------------|----------------------|----|----------------------|---|
| 10 90 20 00 | V2A (1.4301) | 12 | Korn finish 240 | 2 |
| 10 55 02 00 | V4A | 12 | Korn finish 240 | 2 |
| 10 90 41 00 | V2A (1.4301) | 14 | Korn finish 240 | 2 |

Handlaufträger gekröpft mit Innengewinde
handrail support, offset and with internal thread

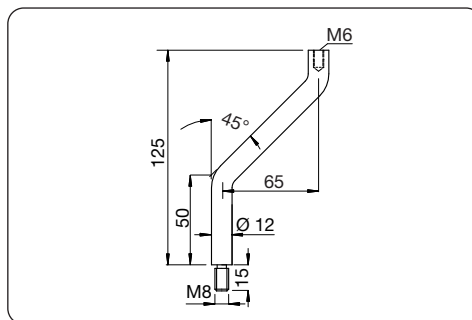

| Art. Nr. item no. | Material material | Oberfläche finish | |
|----------------------|----------------------|----------------------|---|
| 10 90 21 00 | V2A (1.4301) | Korn finish 240 | 2 |

Anschraubplatte gerade für Quadratrohr
adapter plate straight for square tube

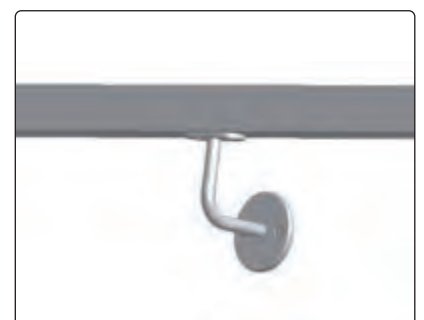
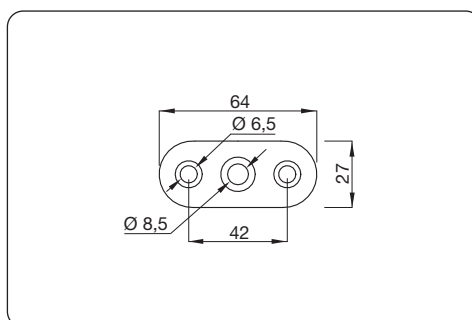

| Art. Nr. item no. | Material material | Oberfläche finish | |
|----------------------|----------------------|----------------------|---|
| 10 90 23 00 | V2A (1.4301) | Korn finish 240 | 2 |
| 10 56 12 00 | V4A | Korn finish 240 | 2 |





■ Anschraubplatte gerade für Rundrohr
adapter plate straight for round tube

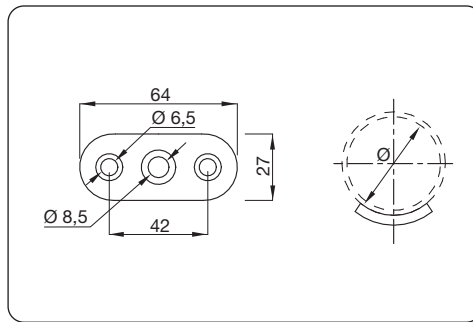

| Art. Nr. item no. | Material material | Ø | Oberfläche finish | |
|----------------------|----------------------|-------------|----------------------|---|
| 10 90 01 00 | V2A (1.4301) | 33,7 - 42,4 | Korn finish 240 | 2 |
| 10 90 36 00 | V2A (1.4301) | 48,3 - 60,3 | Korn finish 240 | 2 |
| 10 55 01 00 | V4A | 33,7 - 42,4 | Korn finish 240 | 2 |

■ Anschraubplatte 135° für Rundrohr
adapter plate 135° for round tube

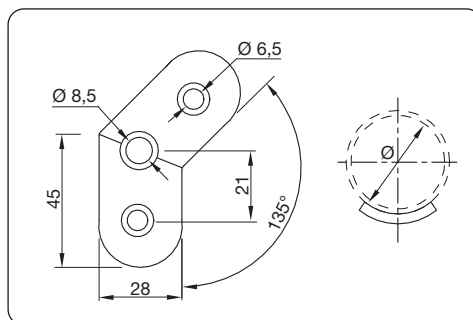

| Art. Nr. item no. | Material material | Ø | Oberfläche finish | |
|----------------------|----------------------|-------------|----------------------|---|
| 10 90 39 00 | V2A (1.4301) | 33,7 - 42,4 | Korn finish 240 | 2 |
| 10 90 40 00 | V2A (1.4301) | 48,3 - 60,3 | Korn finish 240 | 2 |

■ Anschraubplatte 90° für Rundrohr
adapter plate 90° for round tube

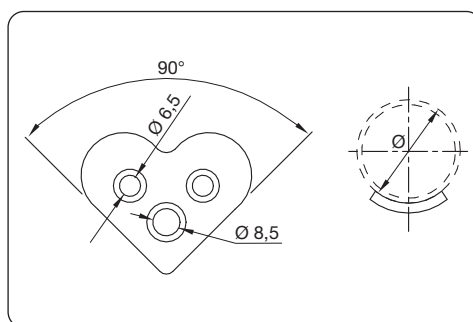

| Art. Nr. item no. | Material material | Ø | Oberfläche finish | |
|----------------------|----------------------|-------------|----------------------|---|
| 10 90 37 00 | V2A (1.4301) | 33,7 - 42,4 | Korn finish 240 | 2 |
| 10 90 38 00 | V2A (1.4301) | 48,3 - 60,3 | Korn finish 240 | 2 |



■ Inhalt | content

- Rohrverbinder für Rundrohr | tube connectors for round tubes 100
- Anschweißbögen | welding elbows 106
- Rohrverbinder für Quadratrohr | tube connectors 107
for square tubes
- Quadratrohr Zubehör | square tube accessories 108

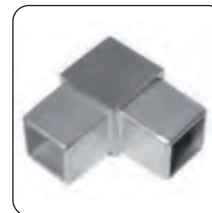

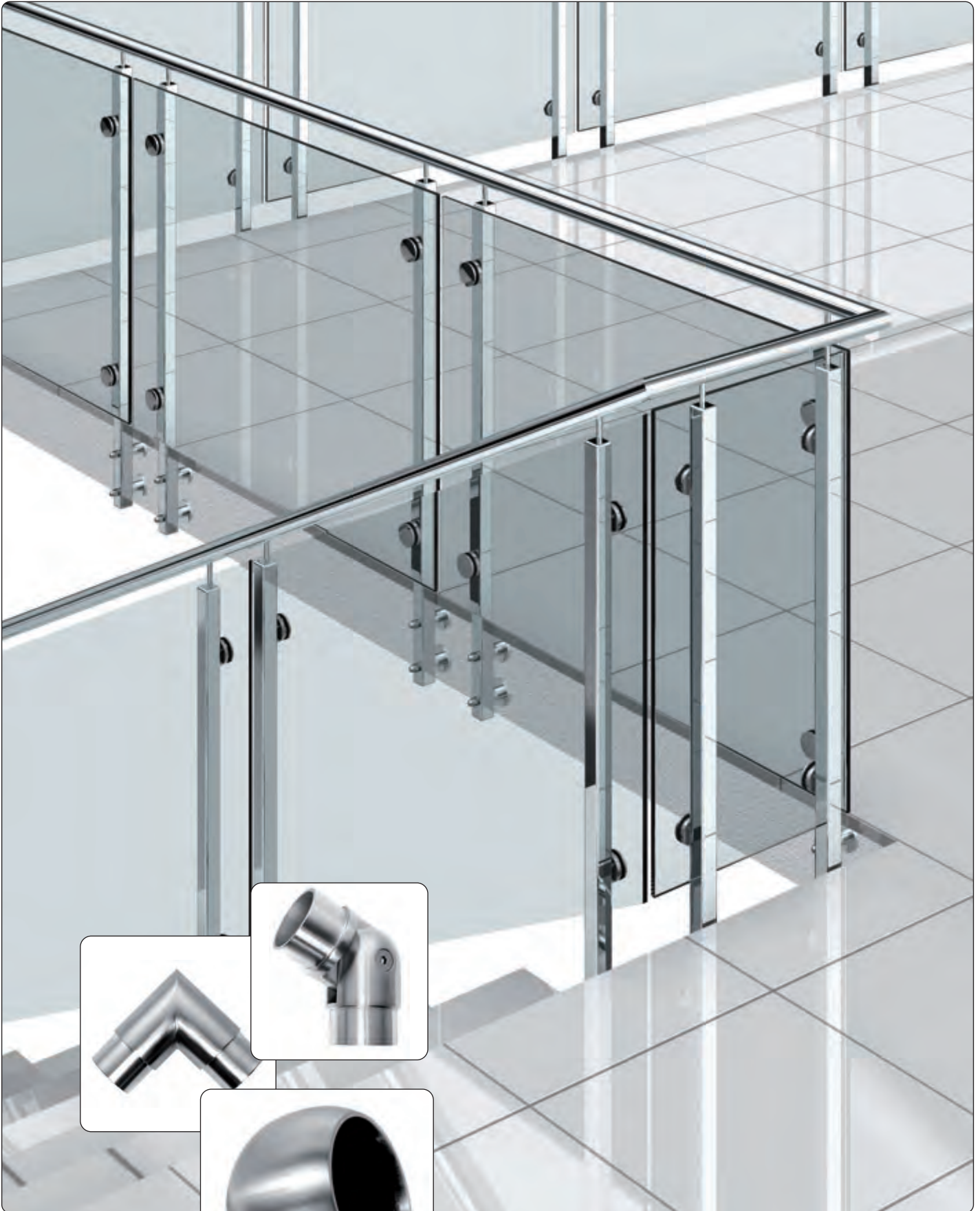

■ Rohrverbinder und Zubehör
tube connectors and accessories



■ Rohrverbinder 90°, rund
tube connector 90°, round

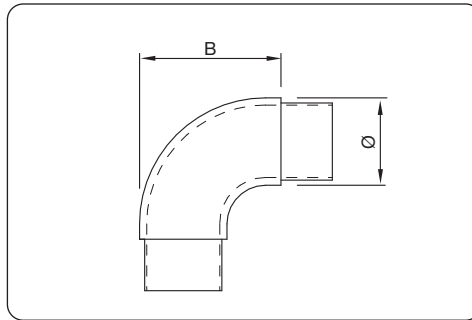

| Art. Nr. item no. | Material material | Ø | B | Oberfläche finish | |
|----------------------|----------------------|------------|----|----------------------|---|
| 10 30 00 00 | V2A (1.4301) | 33,7 x 2,0 | 56 | Korn finish 320 | 2 |
| 10 30 01 00 | V2A (1.4301) | 42,4 x 2,0 | 64 | Korn finish 320 | 2 |
| 10 40 35 00 | V2A (1.4301) | 48,3 x 2,0 | 71 | Korn finish 320 | 2 |
| 10 55 24 00 | V4A | 33,7 x 2,0 | 56 | Korn finish 320 | 2 |
| 10 55 25 00 | V4A | 42,4 x 2,0 | 64 | Korn finish 320 | 2 |

■ Rohrverbinder 90°, eckig
tube connector 90°, square

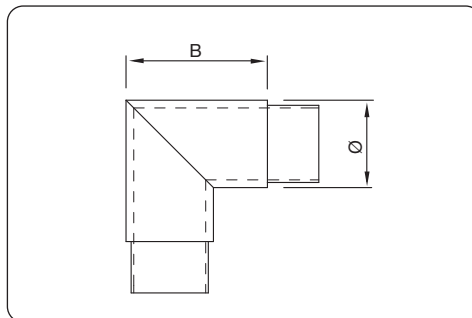

| Art. Nr. item no. | Material material | Ø | B | Oberfläche finish | |
|----------------------|----------------------|------------|----|----------------------|---|
| 10 30 02 00 | V2A (1.4301) | 33,7 x 2,0 | 56 | Korn finish 320 | 2 |
| 10 30 03 00 | V2A (1.4301) | 42,4 x 2,0 | 63 | Korn finish 320 | 2 |
| 10 40 36 00 | V2A (1.4301) | 48,3 x 2,0 | 61 | Korn finish 320 | 2 |
| 10 55 26 00 | V4A | 33,7 x 2,0 | 56 | Korn finish 320 | 2 |
| 10 55 27 00 | V4A | 42,4 x 2,0 | 63 | Korn finish 320 | 2 |





■ Rohrverbinder 135°
tube connector 135°

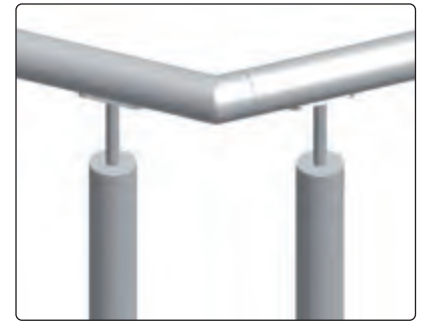
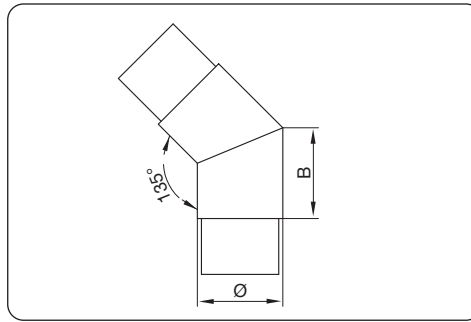

| Art. Nr. item no. | Material material | Ø | B | Oberfläche finish | |
|----------------------|----------------------|------------|----|----------------------|---|
| 10 30 75 00 | V2A (1.4301) | 33,7 x 2,0 | 45 | Korn finish 320 | 2 |
| 10 30 76 00 | V2A (1.4301) | 42,4 x 2,0 | 37 | Korn finish 320 | 2 |
| 10 40 37 00 | V2A (1.4301) | 48,3 x 2,0 | 47 | Korn finish 320 | 2 |
| 10 55 30 00 | V4A | 33,7 x 2,0 | 45 | Korn finish 320 | 2 |
| 10 55 31 00 | V4A | 42,4 x 2,0 | 45 | Korn finish 320 | 2 |

■ Rohrverbinder 180°
tube connector 180°

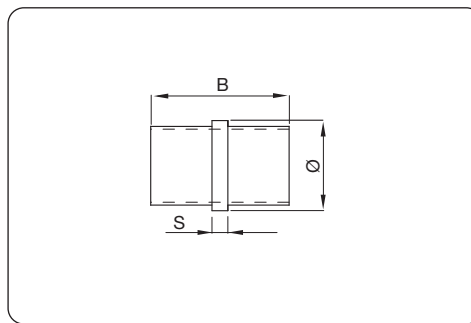

| Art. Nr. item no. | Material material | Ø | B | S | Oberfläche finish | |
|----------------------|----------------------|------------|----|-----|----------------------|---|
| 10 30 78 00 | V2A (1.4301) | 33,7 x 2,0 | 43 | 3,5 | Korn finish 320 | 2 |
| 10 30 79 00 | V2A (1.4301) | 42,4 x 2,0 | 46 | 4,0 | Korn finish 320 | 2 |
| 10 40 38 00 | V2A (1.4301) | 48,3 x 2,0 | 63 | 7,0 | Korn finish 320 | 2 |
| 10 55 34 00 | V4A | 33,7 x 2,0 | 43 | 3,5 | Korn finish 320 | 2 |
| 10 55 35 00 | V4A | 42,4 x 2,0 | 46 | 4,0 | Korn finish 320 | 2 |

■ Rohrverbinder mit Flanschplatte, variabel
tube connector with flange plate, variable

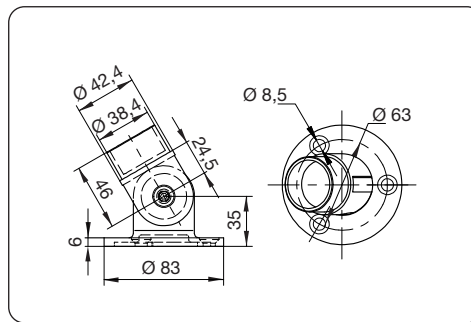

| Art. Nr. item no. | Material material | Ø | Oberfläche finish | |
|----------------------|----------------------|------------|----------------------|---|
| 10 31 30 00 | V4A | 42,4 x 2,0 | Korn finish 320 | 1 |



■ Rohrverbinder mit Gelenk
tube connector with joint

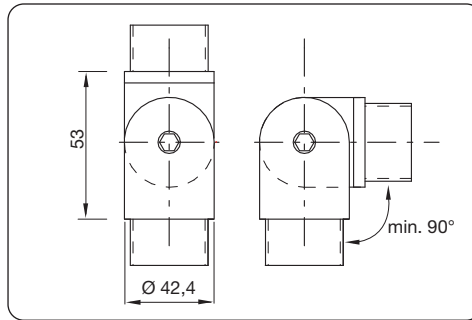

| Art. Nr. item no. | Material material | Ø | B | Oberfläche finish | |
|----------------------|----------------------|------------|----|----------------------|---|
| 10 30 80 00 | V2A (1.4301) | 33,7 x 2,0 | 43 | Korn finish 320 | 1 |
| 10 30 06 00 | V2A (1.4301) | 42,4 x 2,0 | 53 | Korn finish 320 | 1 |
| 10 55 36 00 | V4A | 33,7 x 2,0 | 43 | Korn finish 320 | 1 |
| 10 55 37 00 | V4A | 42,4 x 2,0 | 53 | Korn finish 320 | 1 |

■ Rohrverbinder stufenlos verdrehbar
tube connector, infinitely adjustable

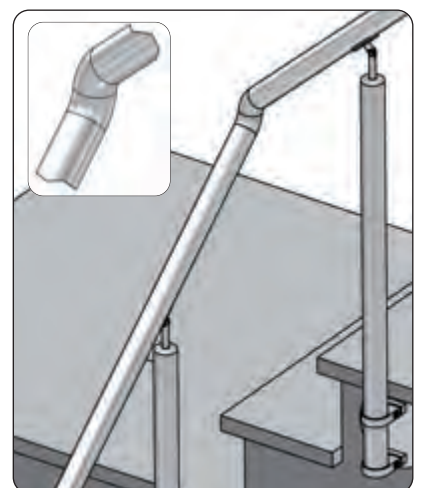
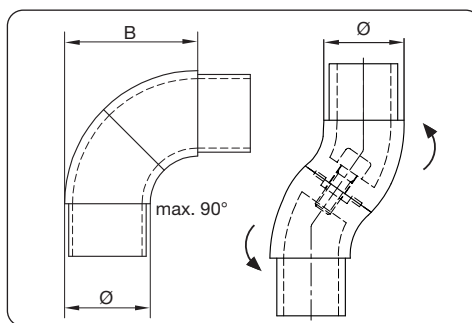

| Art. Nr. item no. | Material material | Ø | B | Oberfläche finish | |
|----------------------|----------------------|------------|----|----------------------|---|
| 10 30 18 00 | V4A | 33,7 x 2,0 | 58 | Korn finish 320 | 1 |
| 10 30 19 00 | V4A | 42,4 x 2,0 | 66 | Korn finish 320 | 1 |

■ T-Stück mit Gelenk
t-connector with joint

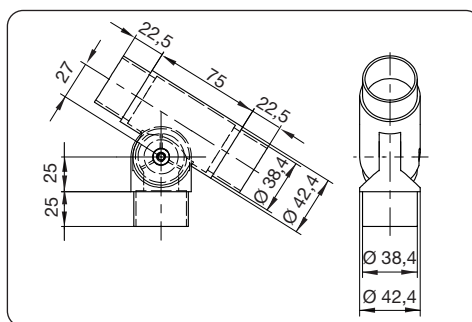

| Art. Nr. item no. | Material material | Ø | Oberfläche finish | |
|----------------------|----------------------|--------------|----------------------|---|
| 10 31 25 00 | V4A | Ø 42,4 x 2,0 | Korn finish 320 | 1 |





■ T-Stück | t-connector

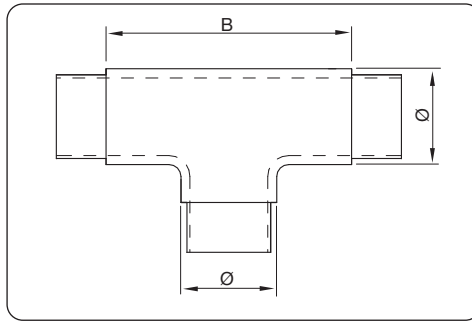
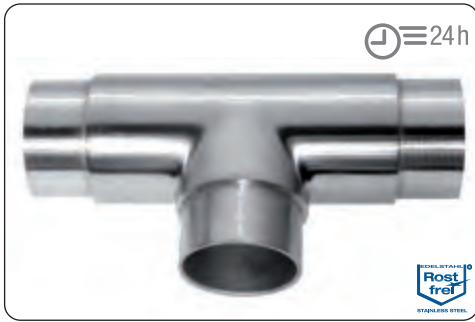

| Art. Nr. item no. | Material material | Ø | B | Oberfläche finish | |
|----------------------|----------------------|------------|----|----------------------|---|
| 10 30 74 00 | V2A (1.4301) | 33,7 x 2,0 | 76 | Korn finish 320 | 1 |
| 10 30 04 00 | V2A (1.4301) | 42,4 x 2,0 | 59 | Korn finish 320 | 1 |
| 10 55 28 00 | V4A | 33,7 x 2,0 | 76 | Korn finish 320 | 1 |
| 10 55 29 00 | V4A | 42,4 x 2,0 | 87 | Korn finish 320 | 1 |

■ Eckverbinder 3-fach | corner connector 3-way

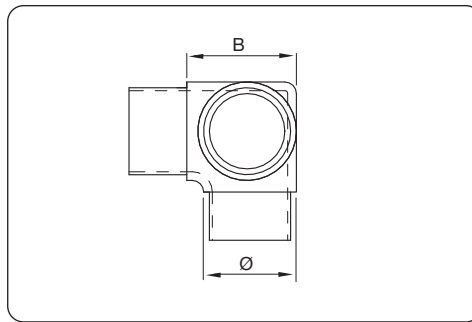

| Art. Nr. item no. | Material material | Ø | B | Oberfläche finish | |
|----------------------|----------------------|------------|----|----------------------|---|
| 10 30 77 00 | V2A (1.4301) | 33,7 x 2,0 | 55 | Korn finish 320 | 1 |
| 10 30 05 00 | V2A (1.4301) | 42,4 x 2,0 | 51 | Korn finish 320 | 1 |
| 10 55 32 00 | V4A | 33,7 x 2,0 | 55 | Korn finish 320 | 1 |
| 10 55 33 00 | V4A | 42,4 x 2,0 | 51 | Korn finish 320 | 1 |

■ Rohrverbinder 4-fach | tube connector 4-way

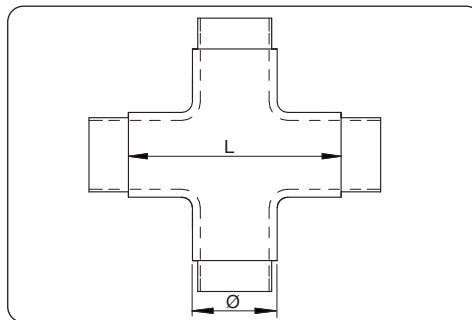

| Art. Nr. item no. | Material material | Ø | L | Oberfläche finish | |
|----------------------|----------------------|------------|----|----------------------|---|
| 10 30 84 00 | V2A (1.4301) | 33,7 x 2,0 | 75 | Korn finish 320 | 1 |
| 10 30 85 00 | V2A (1.4301) | 42,4 x 2,0 | 85 | Korn finish 320 | 1 |
| 10 31 19 00 | V4A | 42,4 x 2,0 | 85 | Korn finish 320 | 1 |



■ Anschlussstück 90°
tube adapter 90°

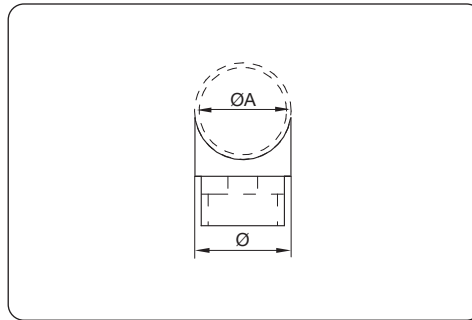

| Art. Nr. item no. | Material material | Ø | Aufnahme ØA adapter ØA | Oberfläche finish | |
|----------------------|----------------------|------------|---------------------------|----------------------|---|
| 10 30 81 00 | V2A (1.4301) | 33,7 x 2,0 | 33,7 | Korn finish 320 | 2 |
| 10 30 56 00 | V2A (1.4301) | 33,7 x 2,0 | 42,4 | Korn finish 320 | 2 |
| 10 30 15 00 | V2A (1.4301) | 42,4 x 2,0 | 42,4 | Korn finish 320 | 2 |
| 10 55 38 00 | V4A | 33,7 x 2,0 | 33,7 | Korn finish 320 | 2 |
| 10 55 61 00 | V4A | 33,7 x 2,0 | 42,4 | Korn finish 320 | 2 |
| 10 55 39 00 | V4A | 42,4 x 2,0 | 42,4 | Korn finish 320 | 2 |

■ Spreizhülse mit Klemmschrauben
expansion sleeve with clamping screws

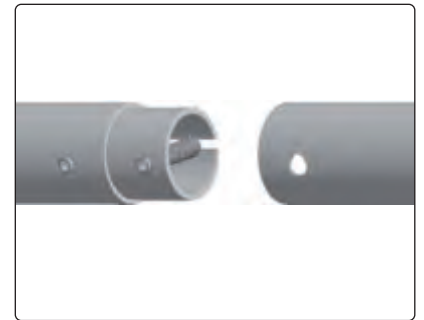
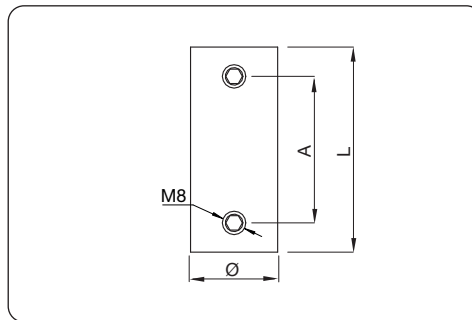

| Art. Nr. item no. | Material material | für Rohr Ø for tube Ø | A | L | Oberfläche finish | |
|----------------------|----------------------|--------------------------|----|----|----------------------|---|
| 10 30 09 00 | V2A (1.4301) | 33,7 x 2,0 | 40 | 60 | roh raw | 2 |
| 10 30 10 00 | V2A (1.4301) | 42,4 x 2,0 | 40 | 60 | roh raw | 2 |
| 10 30 11 00 | V2A (1.4301) | 42,4 x 2,6 | 50 | 70 | roh raw | 2 |

■ Verbindungshülse geschlitzt
slotted connector sleeve

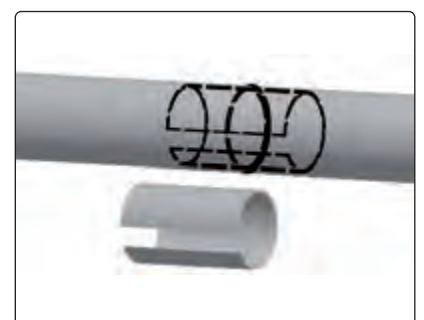
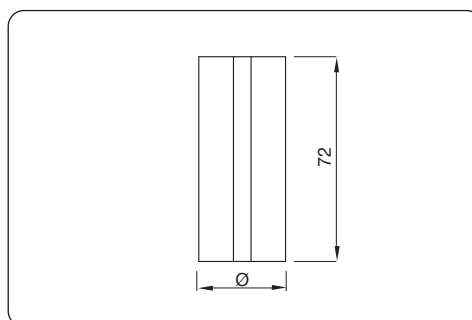

| Art. Nr. item no. | Material material | für Rohr Ø for tube Ø | Oberfläche finish | |
|----------------------|----------------------|--------------------------|----------------------|---|
| 10 30 16 00 | V2A (1.4301) | 33,7 | roh raw | 2 |
| 10 30 17 00 | V2A (1.4301) | 42,4 | roh raw | 2 |





■ Endbogen flach
end elbow flat

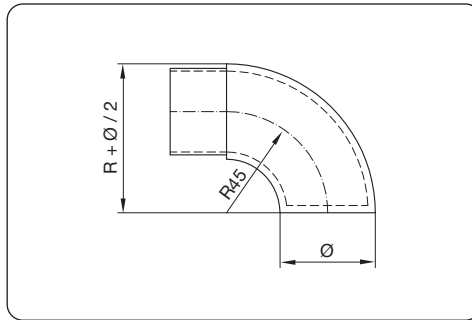

| Art. Nr. item no. | Material material | Ø | Oberfläche finish | |
|----------------------|----------------------|------------|----------------------|---|
| 10 30 97 00 | V2A (1.4301) | 42,4 x 2,0 | Korn finish 320 | 1 |
| 10 55 50 00 | V4A | 33,7 x 2,0 | Korn finish 320 | 1 |
| 10 55 51 00 | V4A | 42,4 x 2,0 | Korn finish 320 | 1 |

■ Endbogen rund
end elbow round

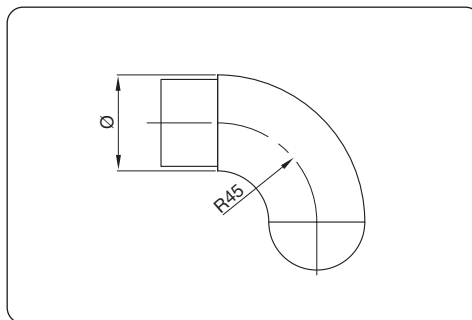

| Art. Nr. item no. | Material material | Ø | Oberfläche finish | |
|----------------------|----------------------|------------|----------------------|---|
| 10 56 03 00 | V4A | 33,7 x 2,0 | Korn finish 320 | 1 |
| 10 56 04 00 | V4A | 42,4 x 2,0 | Korn finish 320 | 1 |
| 10 56 05 00 | V4A | 48,3 x 2,0 | Korn finish 320 | 1 |

■ Rohrabschlusskugel
ball end cap

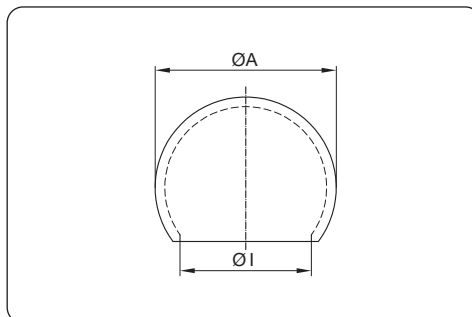

| Art. Nr. item no. | Material material | ØI | ØA | Oberfläche finish | |
|----------------------|----------------------|------|----|----------------------|---|
| 10 60 14 00 | V2A (1.4301) | 33,7 | 45 | Korn finish 320 | 2 |
| 10 60 09 00 | V2A (1.4301) | 42,4 | 55 | Korn finish 320 | 2 |
| 10 60 37 00 | V4A | 42,4 | 55 | Korn finish 320 | 2 |



■ Anschweißbogen 90° | welding elbow 90°

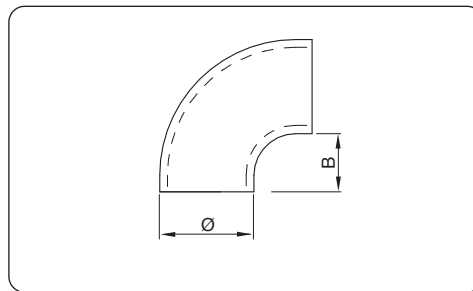

| Art. Nr. item no. | Material material | Ø | B | Oberfläche finish | |
|----------------------|----------------------|------------|----|----------------------|---|
| 10 30 07 00 | V2A (1.4301) | 33,7 x 2,0 | 20 | roh raw | 2 |
| 10 30 08 00 | V2A (1.4301) | 42,4 x 2,0 | 25 | roh raw | 2 |
| 10 30 20 00 | V2A (1.4301) | 48,3 x 2,0 | 32 | roh raw | 2 |
| 10 30 21 00 | V2A (1.4301) | 60,3 x 2,0 | 43 | roh raw | 2 |
| 10 30 22 00 | V2A (1.4301) | 33,7 x 2,0 | 20 | Korn finish 240 | 2 |
| 10 30 23 00 | V2A (1.4301) | 42,4 x 2,0 | 25 | Korn finish 240 | 2 |
| 10 55 20 00 | V4A | 33,7 x 2,0 | 20 | roh raw | 2 |
| 10 55 21 00 | V4A | 42,4 x 2,0 | 25 | roh raw | 2 |
| 10 55 22 00 | V4A | 48,3 x 2,0 | 32 | roh raw | 2 |
| 10 55 23 00 | V4A | 60,3 x 2,0 | 43 | roh raw | 2 |

■ Anschweißbogen 90° | welding elbow 90°

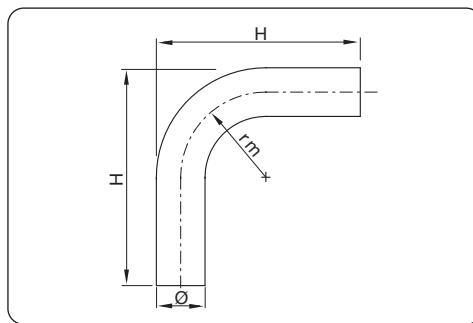

| Art. Nr. item no. | Material material | Ø | rm | H | Oberfläche finish | |
|----------------------|----------------------|------------|-----|-----|----------------------|---|
| 10 90 12 00 | V2A (1.4301) | 33,7 x 2,0 | 70 | 180 | roh raw | 1 |
| 10 90 13 00 | V2A (1.4301) | 42,4 x 2,0 | 100 | 240 | roh raw | 1 |

■ Anschweißbogen 180° | welding elbow 180°

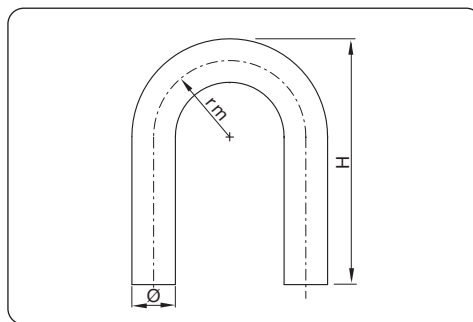

| Art. Nr. item no. | Material material | Ø | rm | H | Oberfläche finish | |
|----------------------|----------------------|------------|-----|-----|----------------------|---|
| 10 90 08 00 | V2A (1.4301) | 33,7 x 2,0 | 70 | 180 | roh raw | 1 |
| 10 90 09 00 | V2A (1.4301) | 42,4 x 2,0 | 64 | 240 | roh raw | 1 |
| 10 90 10 00 | V2A (1.4301) | 42,4 x 2,0 | 85 | 225 | roh raw | 1 |
| 10 90 11 00 | V2A (1.4301) | 42,4 x 2,0 | 100 | 220 | roh raw | 1 |





■ Wandanschluss
wall mounting

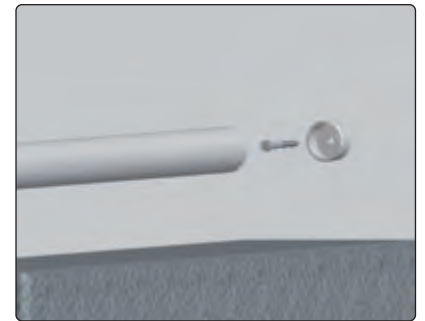
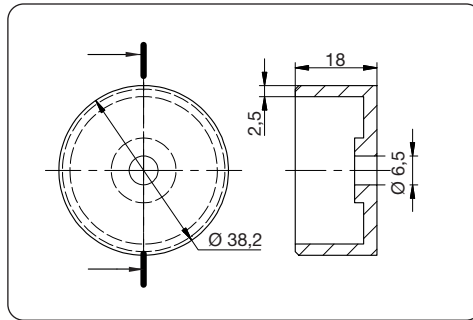

| Art. Nr. item no. | Material material | Rohr tube | Oberfläche finish | |
|----------------------|----------------------|--------------|----------------------|---|
| 10 31 31 00 | V4A | Ø 42,4 x 2,0 | Korn finish 240 | 2 |

■ Flanschplatte mit Rohraufnahme
flange plate with tube adapter

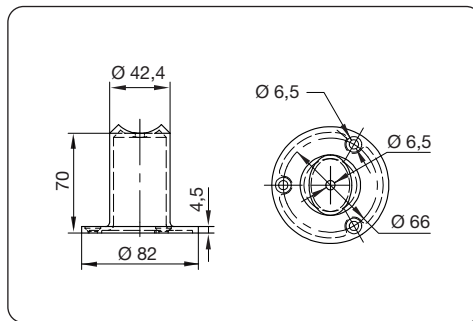
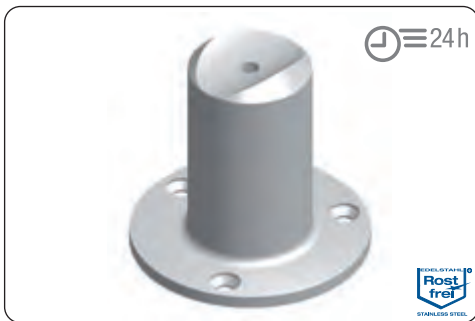

| Art. Nr. item no. | Material material | Aufnahme adapter | Oberfläche finish | |
|----------------------|----------------------|---------------------|----------------------|---|
| 10 31 32 00 | V4A | Ø 42,4 | Korn finish 320 | 1 |

■ Eckverbinder 90°
corner connector 90°

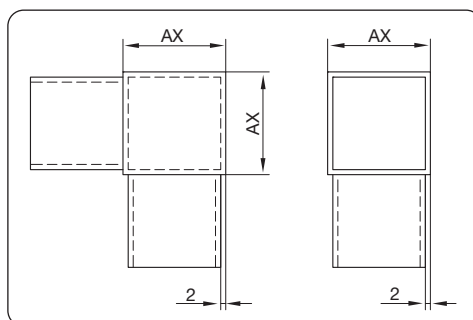

| Art. Nr. item no. | Material material | AX | Oberfläche finish | |
|----------------------|----------------------|---------------|----------------------|---|
| 10 30 48 00 | V4A | 30 x 30 x 2,0 | Korn finish 240 | 2 |
| 10 30 49 00 | V4A | 40 x 40 x 2,0 | Korn finish 240 | 2 |



T-Stück
t-connector

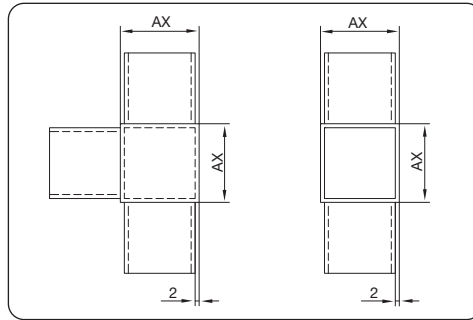

| Art. Nr. item no. | Material material | AX | Oberfläche finish | |
|----------------------|----------------------|---------------|----------------------|---|
| 10 30 50 00 | V4A | 30 x 30 x 2,0 | Korn finish 240 | 1 |
| 10 30 51 00 | V4A | 40 x 40 x 2,0 | Korn finish 240 | 1 |

Eckverbinder 3-fach
corner connector 3-way

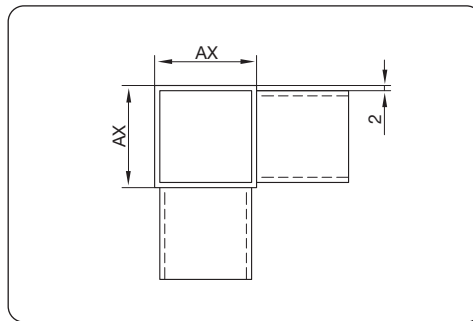

| Art. Nr. item no. | Material material | AX | Oberfläche finish | |
|----------------------|----------------------|---------------|----------------------|---|
| 10 30 52 00 | V4A | 30 x 30 x 2,0 | Korn finish 240 | 1 |
| 10 30 53 00 | V4A | 40 x 40 x 2,0 | Korn finish 240 | 1 |

Verbinder mit Gelenk
connector with joint

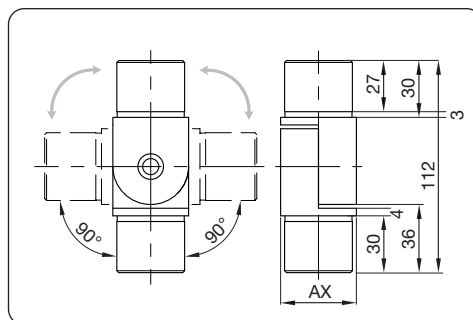

| Art. Nr. item no. | Material material | AX | Oberfläche finish | |
|----------------------|----------------------|---------------|----------------------|---|
| 10 30 57 00 | V4A | 40 x 40 x 2,0 | Korn finish 240 | 1 |





■ Flanschplatte
flange plate

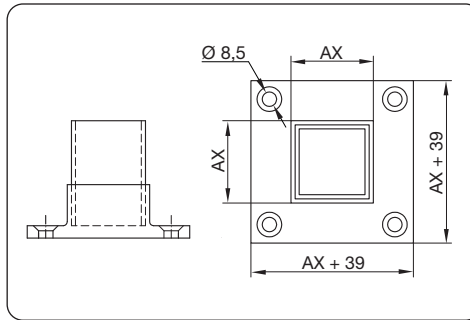
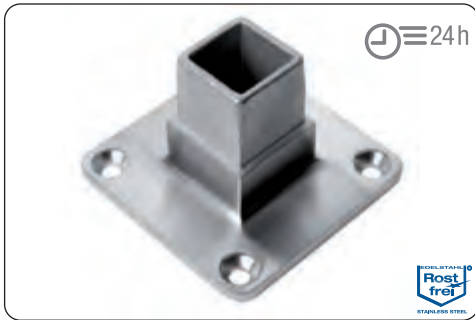

| Art. Nr. item no. | Material material | AX | Oberfläche finish | |
|----------------------|----------------------|---------------|----------------------|---|
| 10 30 54 00 | V4A | 30 x 30 x 2,0 | Korn finish 240 | 1 |
| 10 30 55 00 | V4A | 40 x 40 x 2,0 | Korn finish 240 | 1 |

■ Endkappe flach, hohl
end cap flat, hollow

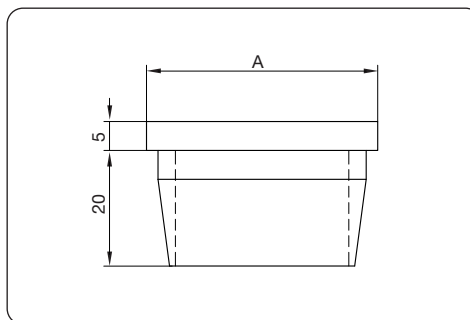

| Art. Nr. item no. | Material material | A Rohr A tube | Oberfläche finish | |
|----------------------|----------------------|------------------|----------------------|---|
| 10 30 86 00 | V2A (1.4301) | 30 x 30 x 2,0 | Korn finish 240 | 2 |
| 10 30 87 00 | V2A (1.4301) | 40 x 40 x 2,0 | Korn finish 240 | 2 |
| 10 30 46 00 | V4A | 30 x 30 x 2,0 | Korn finish 240 | 2 |
| 10 30 47 00 | V4A | 40 x 40 x 2,0 | Korn finish 240 | 2 |

■ Endkappe flach mit Innengewinde, hohl
end cap flat, with internal thread, hollow

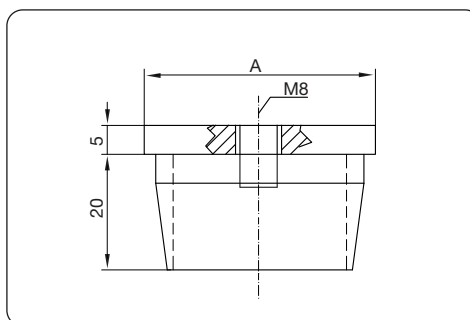

| Art. Nr. item no. | Material material | A Rohr A tube | Oberfläche finish | |
|----------------------|----------------------|------------------|----------------------|---|
| 10 30 88 00 | V2A (1.4301) | 30 x 30 x 2,0 | Korn finish 240 | 2 |
| 10 30 89 00 | V2A (1.4301) | 40 x 40 x 2,0 | Korn finish 240 | 2 |
| 10 31 23 00 | V4A | 30 x 30 x 2,0 | Korn finish 240 | 2 |
| 10 31 24 00 | V4A | 40 x 40 x 2,0 | Korn finish 240 | 2 |

INFO

Unsere Handlaufträger zum Aufschrauben finden Sie auf Seite 94.
You can find our threaded handrail supports on page 94.

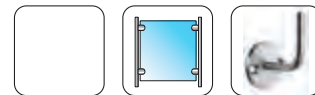

■ Inhalt | content

- Bodenanker | floor anchors 112
- Geländerpfostenhalter | wall mount 113
- Systemplatten | wall mounting plate 115
- Zubehör für Systemplatten | wall mount accessories 116
- Abdeckrosetten | cover plates 117



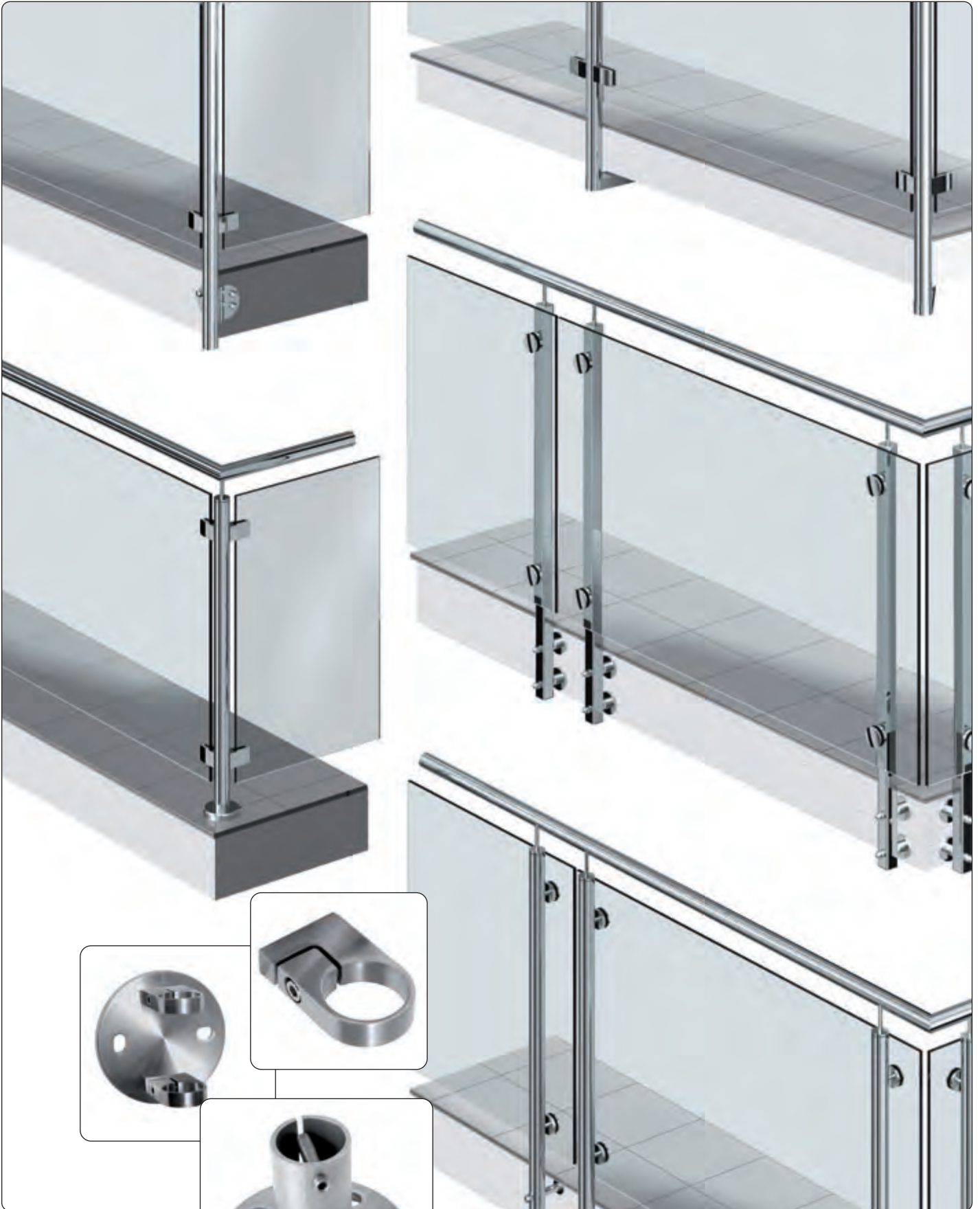

■ Geländerpfostenhalter
balustrade post brackets



■ Bodenanker mit Verbindungshülse | floor anchor with expansion sleeve

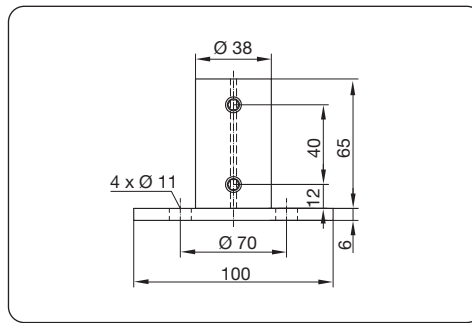

| Art. Nr. item no. | Material material | Rohr \varnothing tube \varnothing | Oberfläche finish | |
|----------------------|----------------------|--|----------------------|---|
| 10 50 07 00 | V2A (1.4301) | 42,4 x 2,0 | roh raw | 1 |
| 10 55 42 00 | V4A | 42,4 x 2,0 | roh raw | 1 |

INFO

Unsere Abdeckrosetten finden Sie auf Seite 117.
For cover plates please see page 117.

■ Bodenanker verstärkt für Rundrohr | floor anchor reinforced for round tube

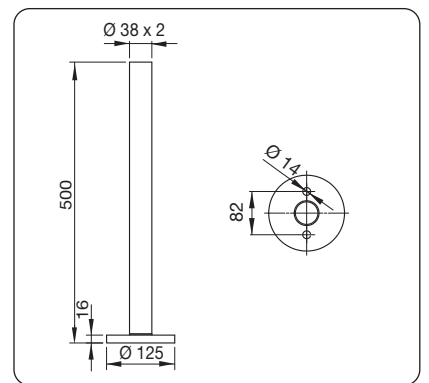
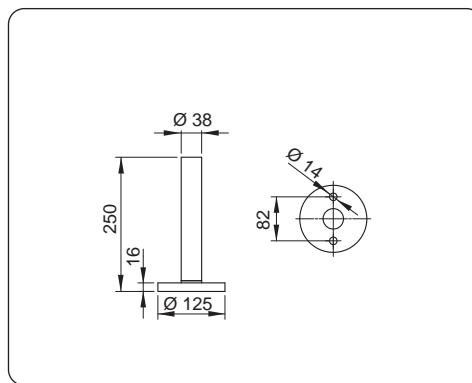

| Art. Nr. item no. | Material material | \varnothing | L | Ausführung design | Oberfläche finish | |
|----------------------|----------------------|---------------|--------|----------------------|----------------------|---|
| 10 50 20 00 | V2A (1.4301) | 38 | 250 mm | Vollmaterial solid | roh raw | 1 |
| 10 50 21 00 | V2A (1.4301) | 38 x 2 | 500 mm | Rohr tube | roh raw | 1 |

INFO

Informationen zur Statik unserer Bodenanker finden Sie auf Seite 222
For information about the statics of our floor anchors please see page 222

■ Bodenanker verstärkt für Rundrohr | floor anchor reinforced for round tube

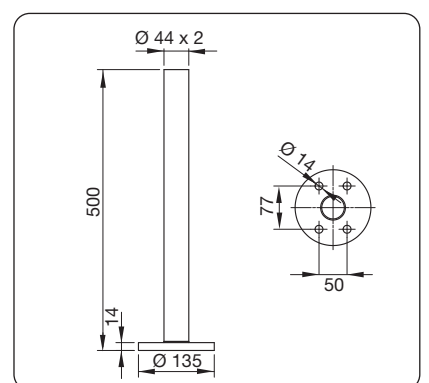
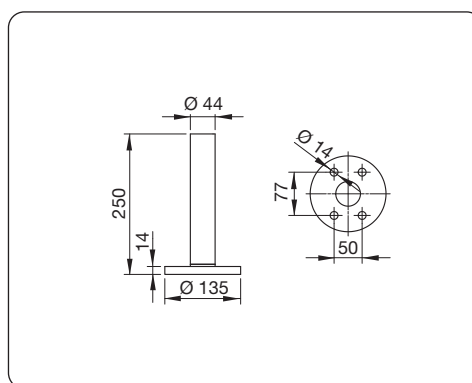

| Art. Nr. item no. | Material material | \varnothing | L | Ausführung design | Oberfläche finish | |
|----------------------|----------------------|---------------|--------|----------------------|----------------------|---|
| 10 50 22 00 | V2A (1.4301) | 44 | 250 mm | Vollmaterial solid | roh raw | 1 |
| 10 50 23 00 | V2A (1.4301) | 44 x 2 | 500 mm | Rohr tube | roh raw | 1 |





■ Geländerpfostenhalter, Schweißmontage
post wall mount for welding

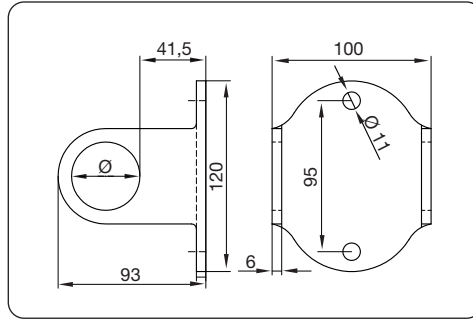

| Art. Nr. item no. | Material material | Ø Rohr Ø tube | Oberfläche finish | |
|----------------------|----------------------|------------------|----------------------|---|
| 10 50 10 00 | V2A (1.4301) | 42,4 | Korn finish 240 | 1 |

■ Geländerpfostenhalter mit Klemmschellen
post wall mount with clamps

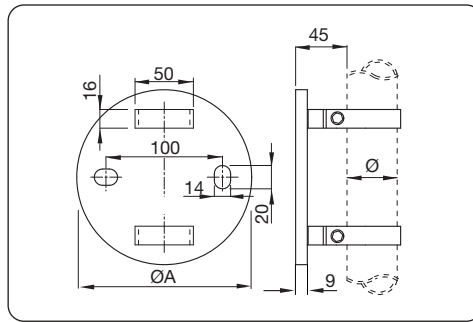

| Art. Nr. item no. | Material material | Ø Rohr Ø tube | ØA | Oberfläche finish | |
|----------------------|----------------------|------------------|-----|----------------------|---|
| 10 40 31 00 | V2A (1.4301) | 42,4 | 150 | Korn finish 240 | 1 |
| 10 40 32 00 | V2A (1.4301) | 42,4 | 120 | Korn finish 240 | 1 |
| 10 40 41 00 | V4A | 42,4 | 150 | Korn finish 240 | 1 |
| 10 40 42 00 | V4A | 42,4 | 120 | Korn finish 240 | 1 |

■ Geländerpfostenhalter mit Spreizhülse
post wall mount with expansion sleeve

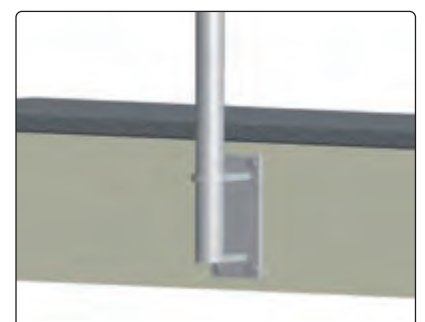
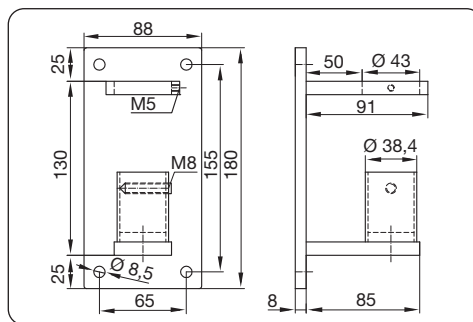

| Art. Nr. item no. | Material material | Ø Rohr Ø tube | Oberfläche finish | |
|----------------------|----------------------|------------------|----------------------|---|
| 10 50 06 00 | V2A (1.4301) | 42,4 x 2,0 | Korn finish 240 | 1 |

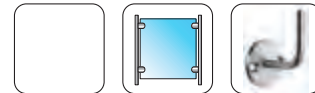

■ Geländerpfostenhalter 90° für Eckpfosten
post wall mount for 90° corners

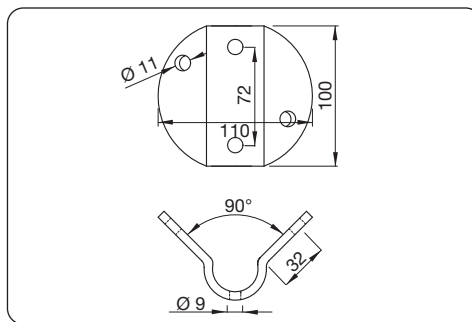

| Art. Nr. item no. | Material material | Oberfläche finish | |
|----------------------|----------------------|----------------------|---|
| 10 50 01 00 | V2A (1.4301) | Korn finish 240 | 2 |

■ Flanschplatte
flange plate

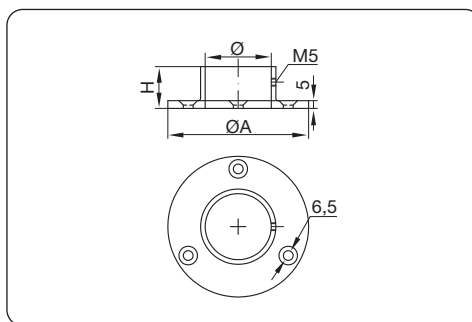

| Art. Nr. item no. | Material material | Rohr Ø tube Ø | ØA | H | Oberfläche finish | |
|----------------------|----------------------|------------------|----|----|-----------------------|---|
| 10 30 82 00 | V2A (1.4301) | 33,7 | 70 | 20 | Korn 320 finish 320 | 2 |
| 10 30 83 00 | V2A (1.4301) | 42,4 | 84 | 25 | Korn 320 finish 320 | 2 |
| 10 30 99 00 | V4A | 33,7 | 70 | 20 | Korn 320 finish 320 | 2 |
| 10 31 17 00 | V4A | 42,4 | 84 | 25 | Korn 320 finish 320 | 2 |

■ Klemmschelle
round tube clamp

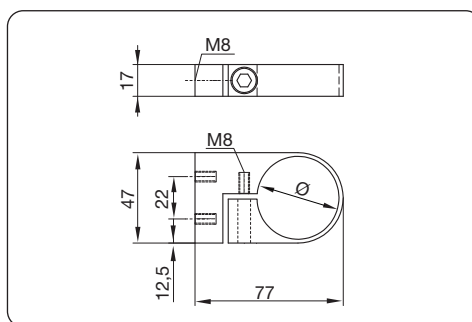

| Art. Nr. | Material material | Rohr Ø tube Ø | Oberfläche finish | |
|-------------|----------------------|------------------|----------------------|---|
| 10 40 30 00 | V2A (1.4301) | 42,4 | Korn finish 240 | 2 |



■ Systemplatte rund
post wall mounting plate round

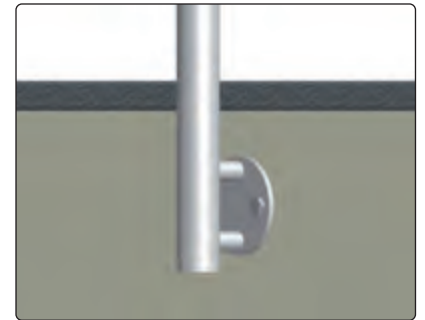
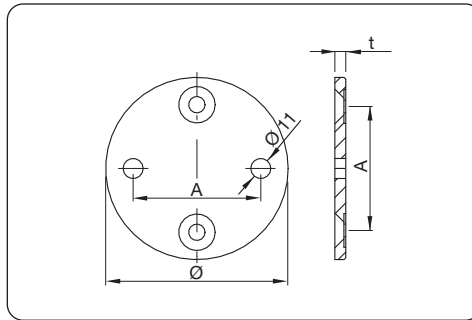

| Art. Nr. item no. | Material material | Ø | A | t | Oberfläche finish | |
|----------------------|----------------------|-----|----|---|----------------------|---|
| 10 50 00 00 | V2A (1.4301) | 100 | 70 | 6 | Korn finish 240 | 2 |
| 10 50 08 00 | V2A (1.4301) | 125 | 95 | 8 | Korn finish 240 | 2 |

■ Systemplatte eckig
post wall mounting plate square

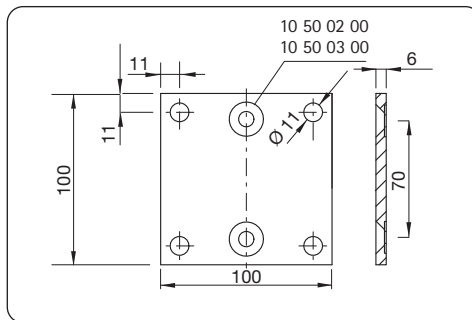

| Art. Nr. item no. | Material material | Oberfläche finish | |
|----------------------|----------------------|----------------------|---|
| 10 50 11 00 | V2A (1.4301) | Korn finish 240 | 2 |





Montageplatte innenliegend
internal mounting plate

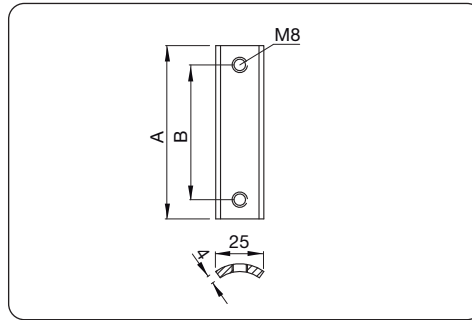

| Art. Nr. item no. | Material material | Ø Rohr Ø tube | A | B | Oberfläche finish | |
|----------------------|----------------------|------------------|-----|----|----------------------|---|
| 10 50 09 00 | V2A (1.4301) | 42,4 | 90 | 70 | roh raw | 2 |
| 10 50 13 00 | V2A (1.4301) | 42,4 | 115 | 95 | roh raw | 2 |

INFO

für die Artikel | for items 10500000 / 10500800 / 10501100

Distanzhülse für Systemplatten
spacer for wall mount

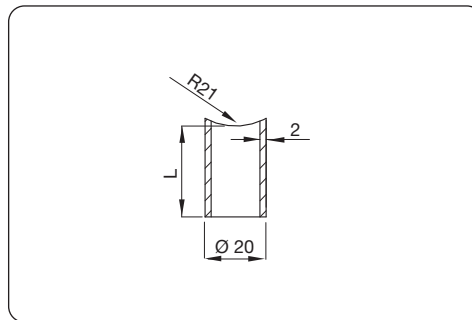

| Art. Nr. item no. | Material material | L | Oberfläche finish | |
|----------------------|----------------------|----|----------------------|---|
| 10 50 02 00 | V2A (1.4301) | 30 | Korn finish 240 | 4 |
| 10 50 03 00 | V2A (1.4301) | 70 | Korn finish 240 | 4 |

INFO

für die Artikel | for items 10500000 / 10500800 / 10501100

Distanzhülse für Systemplatten
spacer for wall mount

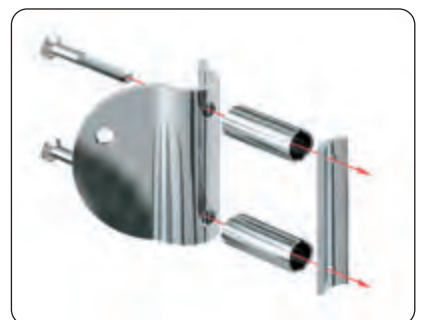
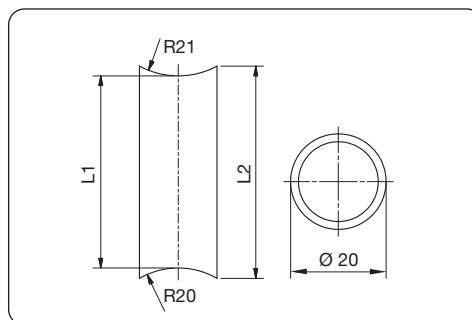

| Art. Nr. item no. | Material material | L1 | L2 | Oberfläche finish | |
|----------------------|----------------------|----|----|----------------------|---|
| 10 50 24 00 | V2A (1.4301) | 50 | 55 | Korn finish 240 | 4 |

INFO

für die Artikel | for items 10500100 / 10500900



Abdeckrosette, gewölbt
cover plate, beveled

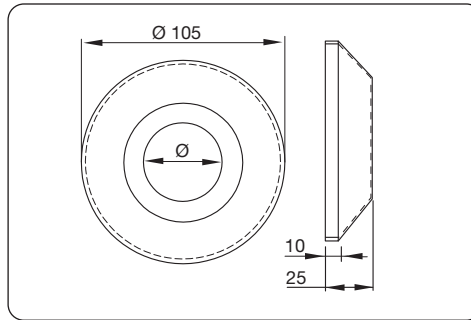

| Art. Nr. item no. | Material material | Ø | Oberfläche finish | |
|----------------------|----------------------|----|----------------------|---|
| 10 20 01 00 | V2A (1.4301) | 43 | Korn finish 240 | 2 |

Abdeckrosette
cover plate

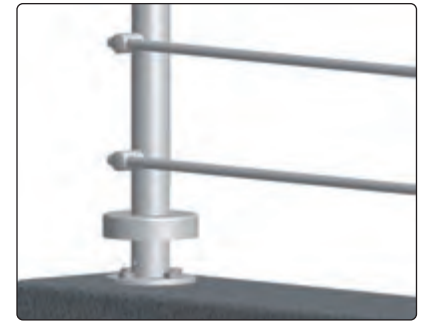
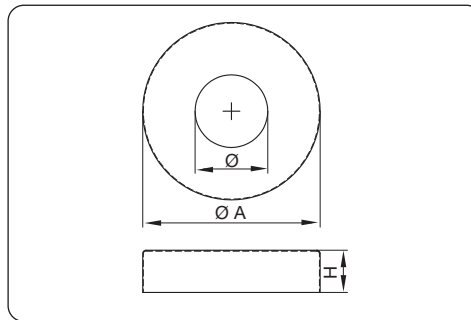

| Art. Nr. item no. | Material material | Ø | ØA | H | Oberfläche finish | |
|----------------------|----------------------|------|-----|----|----------------------|---|
| 10 20 02 00 | V2A (1.4301) | 34,5 | 85 | 15 | Korn finish 240 | 2 |
| 10 20 06 00 | V2A (1.4301) | 43,0 | 85 | 15 | Korn finish 240 | 2 |
| 10 20 03 00 | V2A (1.4301) | 43,0 | 105 | 25 | Korn finish 240 | 2 |
| 10 20 04 00 | V2A (1.4301) | 49,0 | 105 | 25 | Korn finish 240 | 2 |
| 10 55 43 00 | V4A | 43,0 | 105 | 15 | Korn finish 240 | 2 |
| 10 20 10 00 | V2A (1.4301) | 43,0 | 126 | 25 | Korn finish 240 | 2 |
| 10 20 11 00 | V2A (1.4301) | 49,0 | 126 | 25 | Korn finish 240 | 2 |

Abdeckrosette für Vierkantrohr
cover plate for square tube

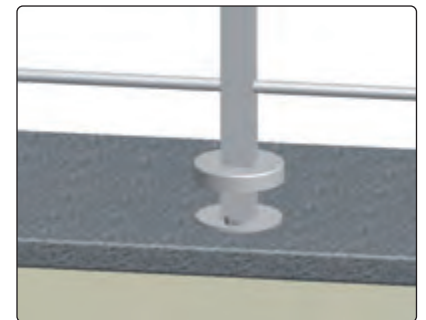
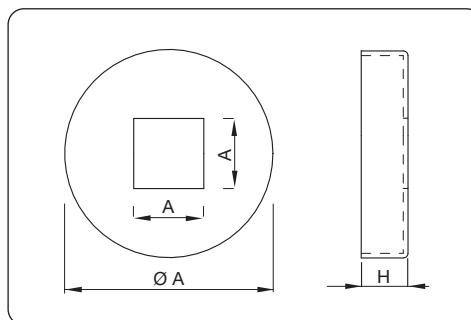

| Art. Nr. item no. | Material material | A | ØA | H | Oberfläche finish | |
|----------------------|----------------------|---------|-----|----|----------------------|---|
| 10 56 13 00 | V4A | 30 x 30 | 85 | 15 | Korn finish 240 | 2 |
| 10 56 14 00 | V4A | 40 x 40 | 105 | 15 | Korn finish 240 | 2 |

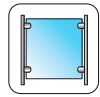

■ Inhalt | content

- Schweißronden | welding plates 120
- Ankerplatten | anchor plates 122
- Anschweißlaschen | welding brackets 123



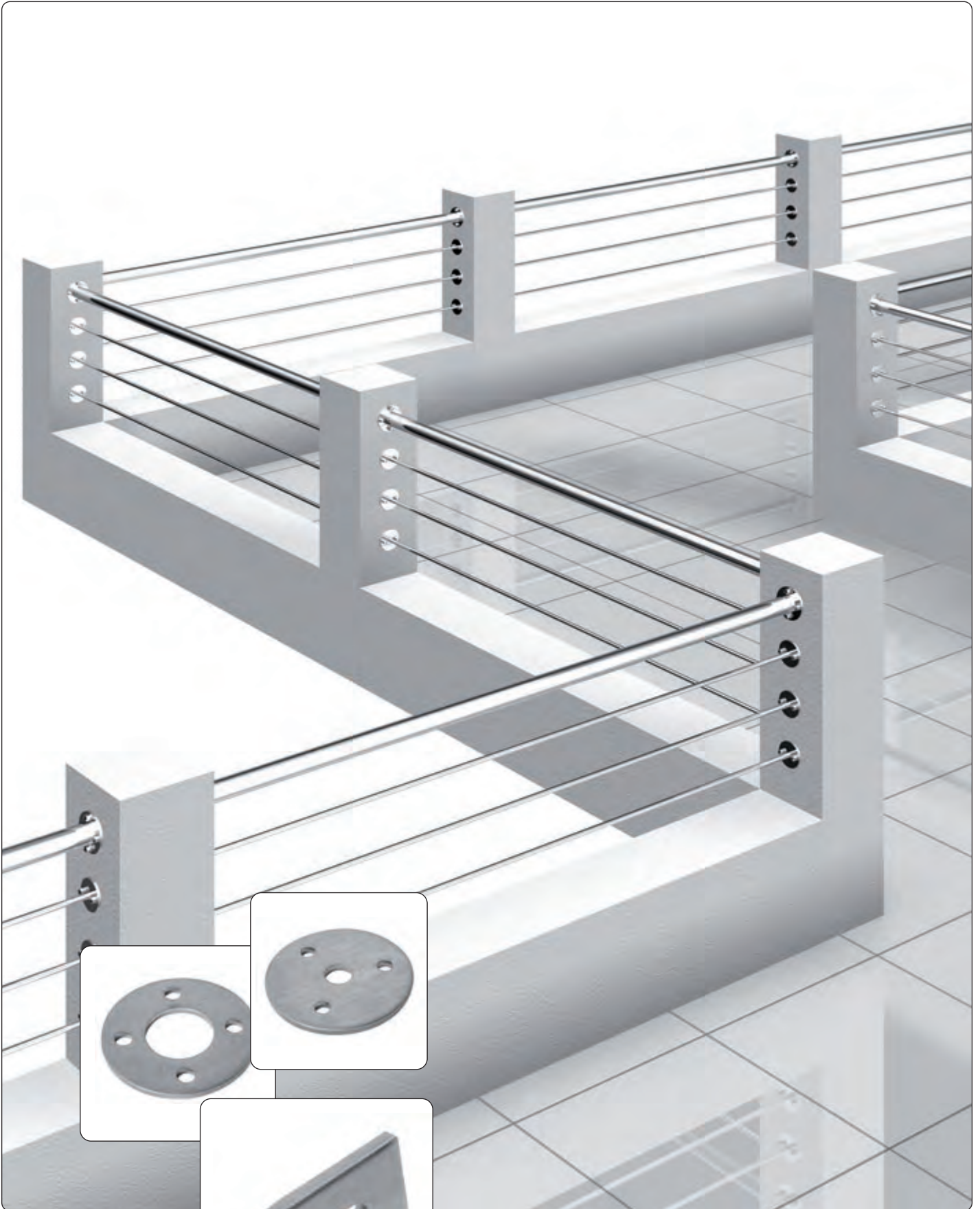

■ Ronden, Ankerplatten und Laschen
round plates, anchor plates and brackets

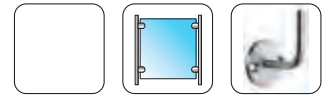

■ Schweißbronde für Rundrohr
welding plates for round tube

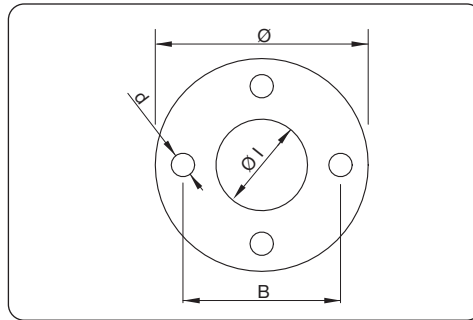
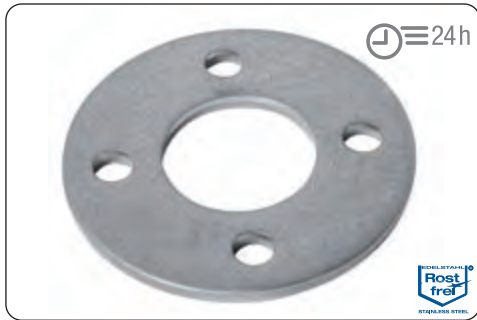

| Art. Nr. item no. | Material material | B | d | ϕ | $\frac{h}{t}$ | $\phi 1$ | Oberfläche finish | |
|----------------------|----------------------|----|-----|--------|---------------|----------|----------------------|---|
| 10 90 30 00 | V2A (1.4301) | 56 | 8,5 | 80 | 6 | 34 | roh raw | 2 |
| 10 90 17 00 | V2A (1.4301) | 70 | 11 | 100 | 6 | 43 | roh raw | 2 |

■ Schweißbronde für Rundstab
welding plates for round bar

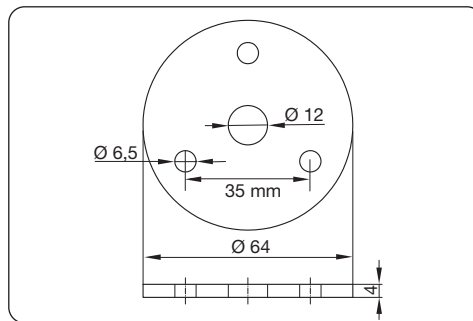

| Art. Nr. item no. | Material material | Oberfläche finish | |
|----------------------|----------------------|----------------------|---|
| 10 90 16 00 | V2A (1.4301) | roh raw | 2 |

■ Schweißbronde, einseitig geschliffen
welding plates, ground from one side

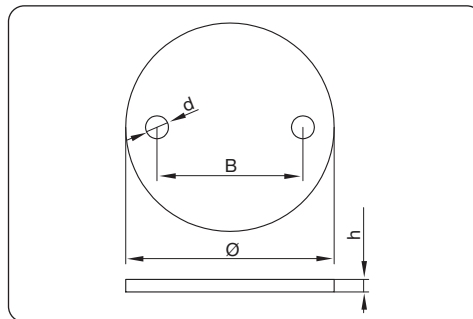

| Art. Nr. item no. | Material material | B | d | ϕ | h | Oberfläche finish | |
|----------------------|----------------------|----|-----|--------|---|----------------------|---|
| 10 80 00 00 | V2A (1.4301) | 43 | 6,5 | 60 | 4 | Korn finish 240 | 2 |
| 10 80 12 00 | V2A (1.4301) | 46 | 11 | 70 | 6 | Korn finish 240 | 2 |
| 10 80 01 00 | V2A (1.4301) | 50 | 11 | 80 | 4 | Korn finish 240 | 2 |
| 10 80 02 00 | V2A (1.4301) | 75 | 11 | 100 | 6 | Korn finish 240 | 2 |
| 10 55 41 00 | V4A | 75 | 11 | 100 | 6 | Korn finish 240 | 2 |
| 10 80 03 00 | V2A (1.4301) | 90 | 11 | 120 | 6 | Korn finish 240 | 2 |





■ Schweißbronde, einseitig geschliffen
welding plates, ground from one side

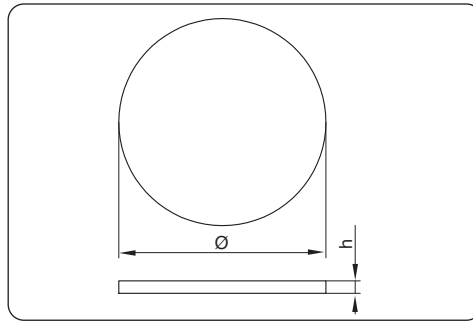

| Art. Nr. item no. | Material material | Ø | h | Oberfläche finish | |
|----------------------|----------------------|-----|---|----------------------|---|
| 10 80 13 00 | V2A (1.4301) | 33 | 4 | Korn finish 240 | 2 |
| 10 80 14 00 | V2A (1.4301) | 42 | 4 | Korn finish 240 | 2 |
| 10 80 15 00 | V2A (1.4301) | 48 | 4 | Korn finish 240 | 2 |
| 10 80 16 00 | V2A (1.4301) | 60 | 4 | Korn finish 240 | 2 |
| 10 80 17 00 | V2A (1.4301) | 70 | 6 | Korn finish 240 | 2 |
| 10 55 48 00 | V4A | 70 | 6 | Korn finish 240 | 2 |
| 10 80 10 00 | V2A (1.4301) | 80 | 4 | Korn finish 240 | 2 |
| 10 80 11 00 | V2A (1.4301) | 100 | 6 | Korn finish 240 | 2 |

■ Schweißbronde, roh
welding plate, raw

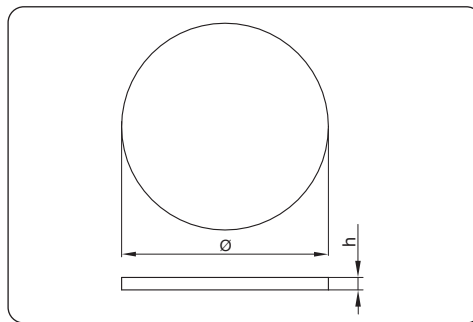

| Art. Nr. item no. | Material material | Ø | h | Oberfläche finish | |
|----------------------|----------------------|-----|---|----------------------|---|
| 10 80 04 00 | V2A (1.4301) | 60 | 4 | roh raw | 2 |
| 10 80 05 00 | V2A (1.4301) | 80 | 4 | roh raw | 2 |
| 10 80 06 00 | V2A (1.4301) | 100 | 6 | roh raw | 2 |
| 10 80 07 00 | V2A (1.4301) | 120 | 6 | roh raw | 2 |

INFO

Unsere Abdeckrosetten finden Sie auf Seite 117.
For cover plates please see page 117.



- Ankerplatte, einseitig geschliffen
anchor plate, ground from one side

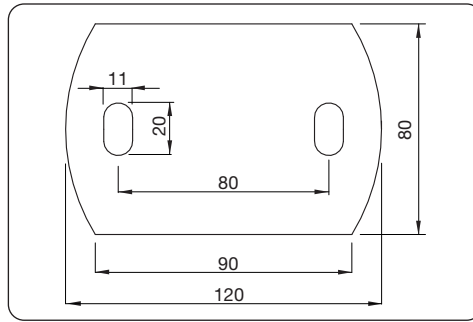
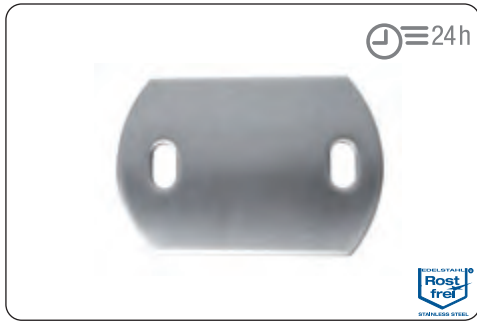

| Art. Nr. item no. | Material material | ⚡ | Oberfläche finish | 🔩 |
|----------------------|----------------------|---|----------------------|---|
| 10 80 19 00 | V2A (1.4301) | 6 | Korn finish 240 | 2 |

- Ankerplatte, einseitig geschliffen
anchor plate, ground from one side

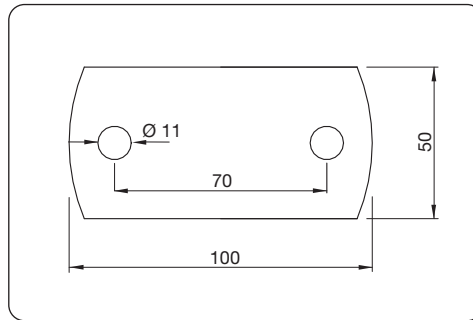
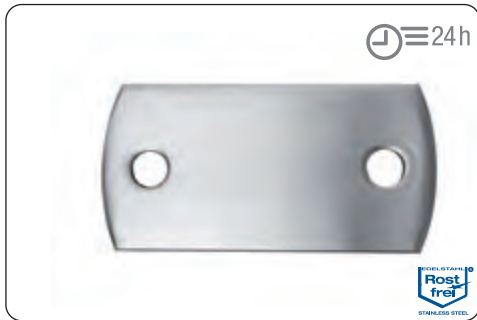

| Art. Nr. item no. | Material material | ⚡ | Oberfläche finish | 🔩 |
|----------------------|----------------------|---|----------------------|---|
| 10 80 08 00 | V2A (1.4301) | 6 | Korn finish 240 | 2 |

- Ankerplatte, einseitig geschliffen
anchor plate, ground from one side

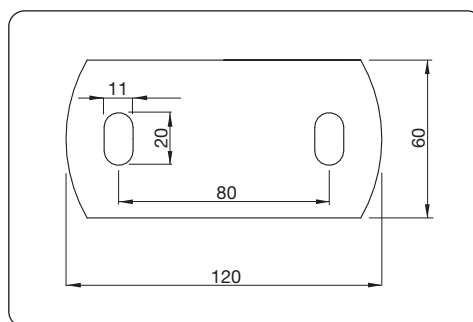

| Art. Nr. item no. | Material material | ⚡ | Oberfläche finish | 🔩 |
|----------------------|----------------------|---|----------------------|---|
| 10 80 09 00 | V2A (1.4301) | 6 | Korn finish 240 | 2 |
| 10 55 47 00 | V4A | 6 | Korn finish 240 | 2 |





■ Anschweißlasche
welding bracket

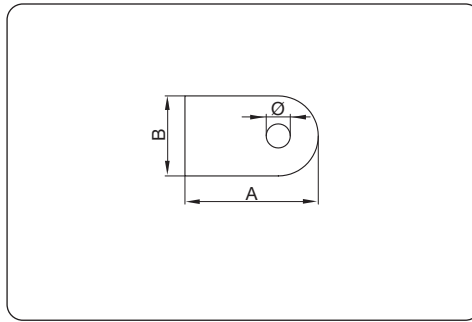

| Art. Nr. item no. | Material material | ⚡ | A | B | Ø | Oberfläche finish | 📄 |
|----------------------|----------------------|---|----|----|---|----------------------|---|
| 10 90 14 00 | V2A (1.4301) | 5 | 50 | 30 | 9 | roh raw | 4 |
| 10 90 48 00 | V2A (1.4301) | 5 | 30 | 20 | 7 | roh raw | 4 |

■ Anschweißlasche
welding bracket

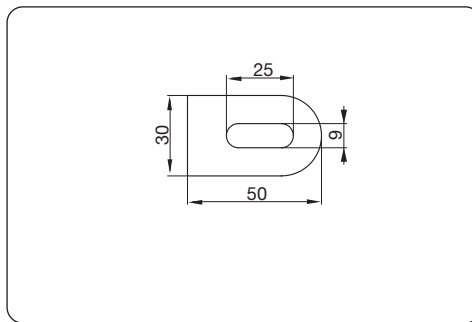

| Art. Nr. item no. | Material material | ⚡ | Oberfläche finish | 📄 |
|----------------------|----------------------|---|----------------------|---|
| 10 90 15 00 | V2A (1.4301) | 5 | roh raw | 4 |

Pflegeprodukte Seite
treatment products 608-615
Pflegeinfo Seite | treatment
instructions 621-622



■ Inhalt | content

- Edelstahlnutsystem | stainless steel slotted tube system 126
- Holznutsystem | slotted wood system 128
- Zubehör für Nutsysteme | slotted tube system accessories 130
- Bodenanker für Glasbefestigungen 131
floor anchors for glass fixation



INFO

Hinweis auf TRAV Kategorie B Seite 130
Information about TRAV category B on
page 130

Mehr Informationen über Pfostenab-
ständen finden Sie auf Seite 222
More information about post spacings
you will find on page 222



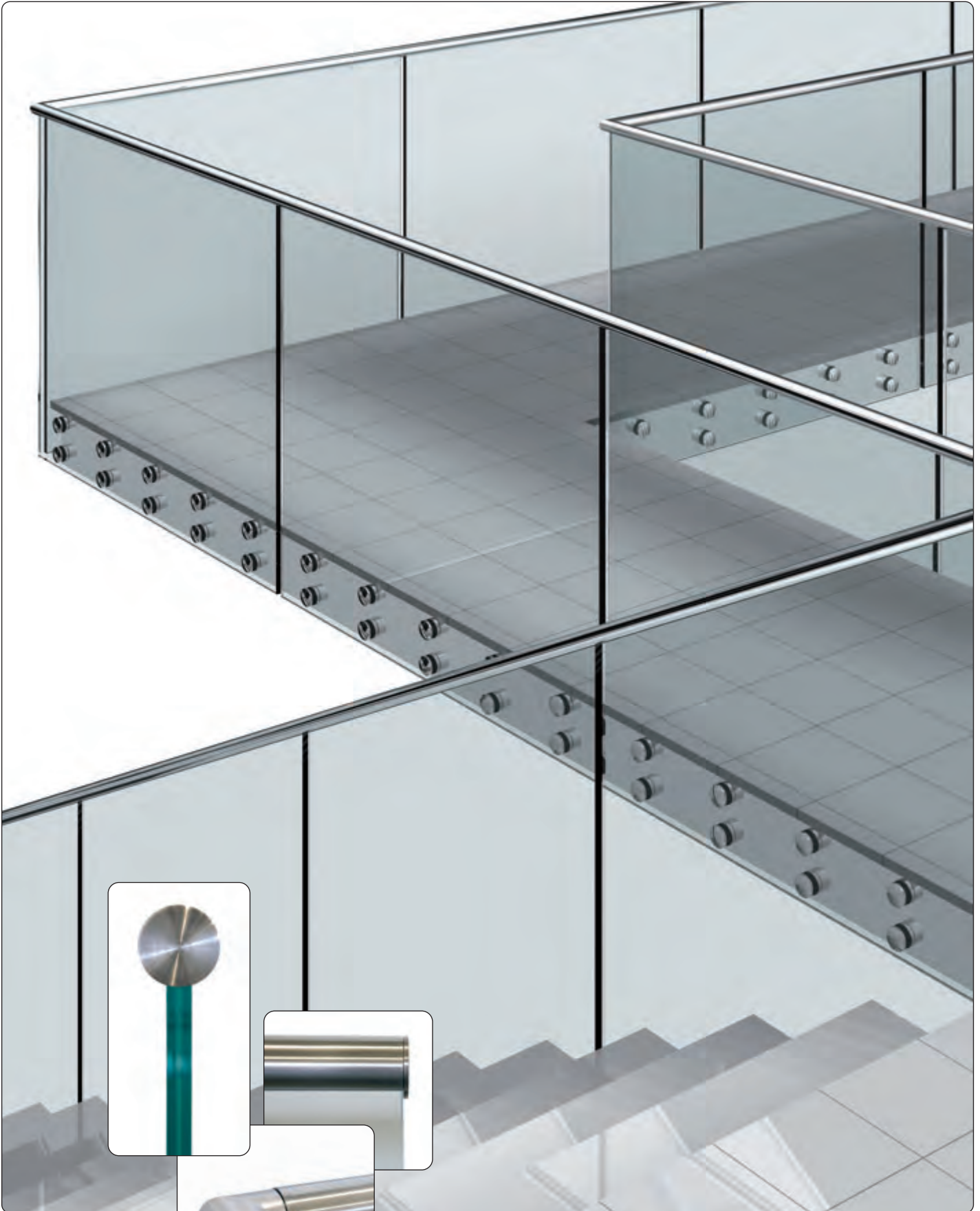

■ Nutrohrsysteme
slotted tube systems



Nutrohr
slotted round tube

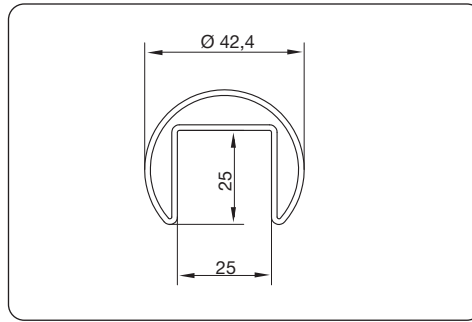

| Art. Nr. item no. | Material material | Ø | L | Oberfläche finish | |
|----------------------|----------------------|------------|------|----------------------|---|
| 11 10 18 00 | V4A | 42,4 x 1,5 | 6000 | Korn finish 240 | 1 |

INFO

Informationen zur TRAV Kategorie B finden Sie auf Seite 130
For information about TRAV categorie B please see page 130

Rohrverbinder für Nutrohr, vertikal
corner connector vertical, for slotted round tube

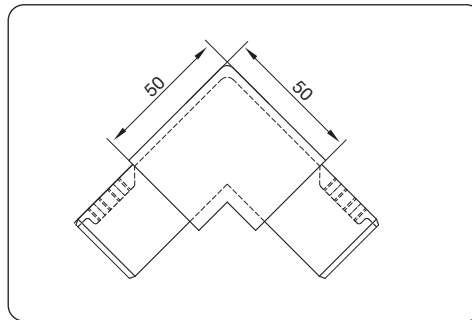

| Art. Nr. item no. | Material material | Ø | Oberfläche finish | |
|----------------------|----------------------|------------|----------------------|---|
| 11 10 19 00 | V4A | 42,4 x 1,5 | Korn finish 240 | 2 |

Rohrverbinder für Nutrohr, horizontal
corner connector horizontal, for slotted round tube

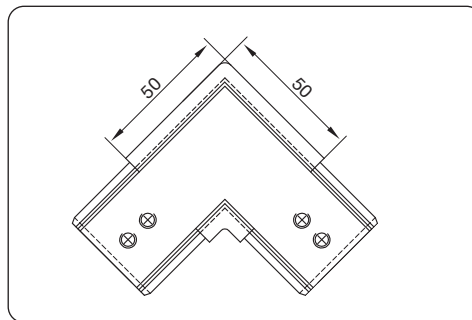

| Art. Nr. item no. | Material material | Ø | Oberfläche finish | |
|----------------------|----------------------|------------|----------------------|---|
| 11 10 20 00 | V4A | 42,4 x 1,5 | Korn finish 240 | 2 |





■ Nutrohranschlussstück 90°
slotted round tube connector 90°

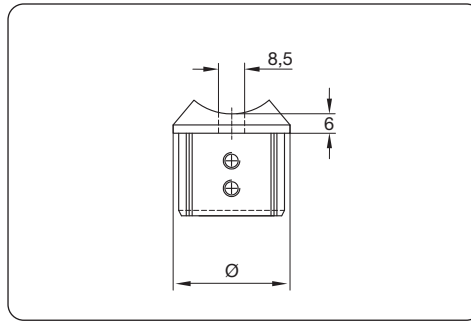

| Art. Nr. item no. | Material material | Ø | Aufnahme adapter | Oberfläche finish | |
|----------------------|----------------------|------------|---------------------|----------------------|---|
| 11 10 21 00 | V4A | 42,4 x 1,5 | Ø 42,4 | Korn finish 240 | 2 |

■ Rohrverbinder für Nutrohr 180°
slotted round tube connector 180°

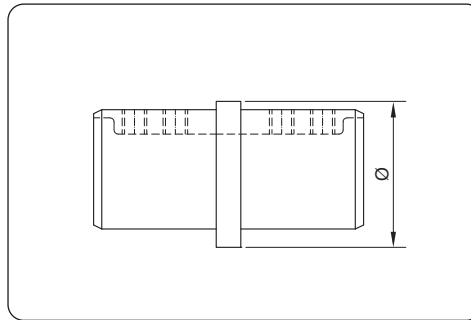

| Art. Nr. item no. | Material material | Ø | Oberfläche finish | |
|----------------------|----------------------|------------|----------------------|---|
| 11 10 22 00 | V4A | 42,4 x 1,5 | Korn finish 240 | 2 |

■ Wandanschlussstück für Nutrohr
slotted round tube connector, wall mounting

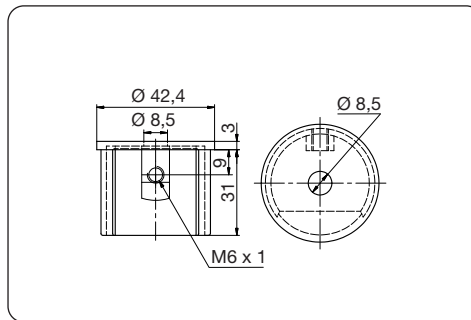
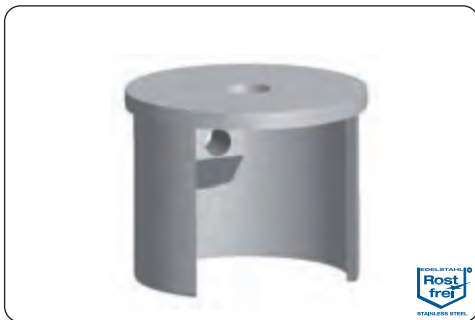

| Art. Nr. item no. | Material material | für Rohr Ø for tube Ø | Oberfläche finish | |
|----------------------|----------------------|--------------------------|----------------------|---|
| 11 10 29 00 | V4A | 42,4 x 1,5 | Korn finish 240 | 2 |



Nutrohrendkappe flach
slotted round tube end cap, flat

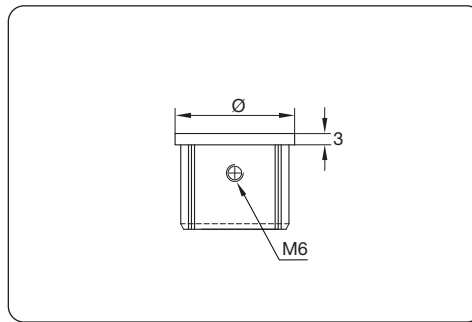

| Art. Nr. item no. | Material material | für Rohr Ø for tube Ø | Oberfläche finish | |
|----------------------|----------------------|--------------------------|----------------------|---|
| 11 10 23 00 | V4A | 42,4 x 1,5 | Korn finish 240 | 2 |

■ Holzhandlauf genutet, Natur
slotted wooden handrail, natural

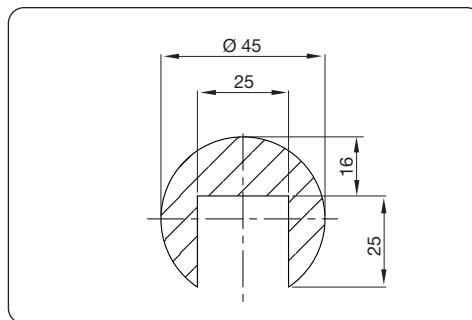

| Art. Nr. item no. | Länge length | |
|----------------------|-----------------|---|
| 10 31 39 00 | 2000 | 1 |

INFO
Alle Holzhandläufe sind mit Klarlack endbehandelt . | All wooden handrails are finished with clear lacquer.

■ Holzhandlauf genutet, Wenge
slotted wooden handrail, wenge

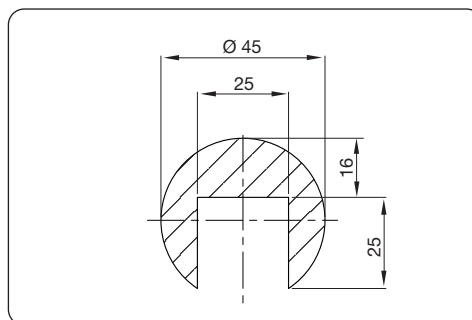

| Art. Nr. item no. | Länge length | |
|----------------------|-----------------|---|
| 10 31 40 00 | 2000 | 1 |

INFO
Alle Holzhandläufe sind mit Klarlack endbehandelt . | All wooden handrails are finished with clear lacquer.





- Handlaufverbinder, genutet
handrail connector, slotted

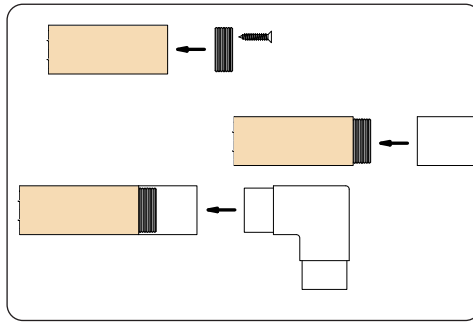

| Art. Nr. item no. | Ø | |
|----------------------|------|---|
| 10 31 41 00 | 42,4 | 2 |

- Holzhandlauf genutet, Natur
wooden handrail, slotted, natural

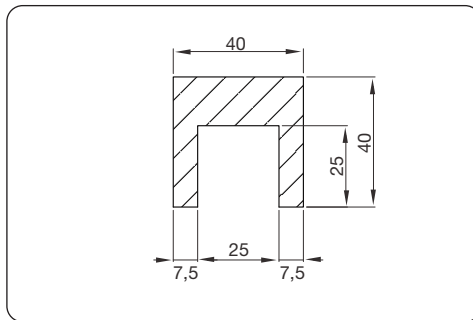

| Art. Nr. item no. | Länge length | |
|----------------------|-----------------|---|
| 10 31 37 00 | 2000 | 1 |

INFO

Alle Holzhandläufe sind mit Klarlack endbehandelt. | All wooden handrails are finished with clear lacquer.

- Holzhandlauf genutet, Wenge
wooden handrail, slotted, wenge

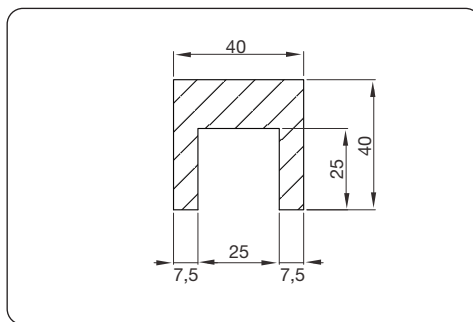

| Art. Nr. item no. | Länge length | |
|----------------------|-----------------|---|
| 10 31 38 00 | 2000 | 1 |

INFO

Alle Holzhandläufe sind mit Klarlack endbehandelt. | All wooden handrails are finished with clear lacquer.



■ Elastomer-Profil für Nutsysteme
elastomeric profile for slotted tube systems



| Art. Nr. item no. | Glasstärke glass thickness | Ø | |
|----------------------|-------------------------------|------------|---------------|
| 11 10 24 00 | 8 - 13 | 42,4 x 1,5 | 1lfm 1 /mtr |
| 11 10 25 00 | 14 - 18 | 42,4 x 1,5 | 1lfm 1 /mtr |
| 11 10 26 00 | 20 - 24 | 42,4 x 1,5 | 1lfm 1 /mtr |

■ Punkthalter erhaben (TRAV)
point fixing, raised head (TRAV)

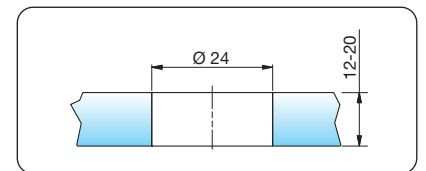
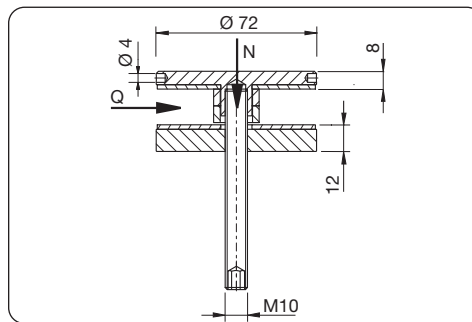
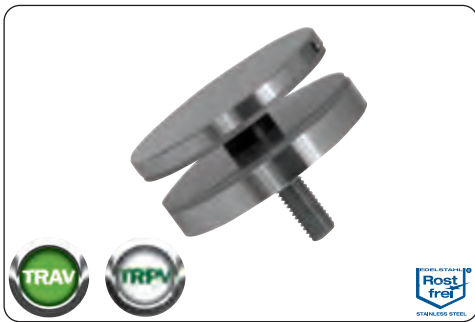

| Art. Nr. item no. | Material material | max. Q | max. N | |
|----------------------|----------------------|--------|--------|---|
| 13 90 09 00 | A2 (1.4301) | 4,0 kn | 6,0 kn | 4 |

Zubehör | accessories



17012800

inklusive | includes



DIN913 M10 x 90 mm

INFO

Mehr Informationen zur TRAV finden Sie auf Seite 236. | For information about TRAV please see page 236.

■ Edelstahlnutrohr | stainless steel slotted round tube

Bei diesem Produkt handelt es sich um einen TRAV-konformen Handlauf nach Kategorie B, für VSG 20 mit PVB 1,52 mm und mit einem Glaseinstand von mindestens 15 mm. Es darf VSG aus 2x10 ESG oder 2x10 TVG verwendet werden. Der Glas-Metallkontakt wird durch das Aufstecken von einem Elastomer-Profil (Abstand ca. 200 - 300 mm) auf die Scheibe verhindert. Die Verbindung des Handlaufes mit den Scheiben erfolgt durch die Verfüllung des verbleibenden Hohlraumes im U-Profil mit Dichtstoffen nach DIN 18 545-2 Gruppe E.

This product is a TRAV-compliant Category B handrail for 20 mm laminated safety glass with 1.52 mm PVB and a glass mounting depth of at least 15 mm. Laminated safety glass with 2x10 mm tempered or heat-strengthened safety glass may be used. Glass/metal contact is prevented by attaching an elastomeric profile (with a gap of approx. 200-300 mm) to the glass panel. The handrail is connected to the glass panels by filling the remaining cavity in the U-profile with sealants in accordance with DIN 18 545-2 Group E.
Mehr auf Seite 241 | more on page 241





■ Bodenanker für Glasbefestigungen, rund
floor anchor with glass clamp, round

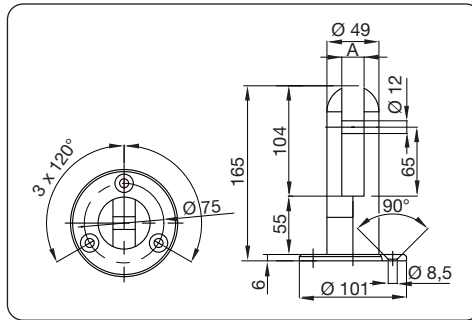

INFO
Glas und Metall sind durch EPDM-Schicht zu trennen. | Glass and metal must be separated by an epdm washer.

| Art. Nr. item no. | Material material | A | Oberfläche finish | |
|----------------------|----------------------|------------|----------------------|---|
| 11 10 27 00 | V2A (1.4301) | 12 - 17,52 | Korn finish 240 | 1 |
| 10 55 65 00 | V4A | 12 - 17,52 | Korn finish 240 | 1 |

■ Bodenanker für Glasbefestigungen, eckig
floor anchor with glass clamp, square

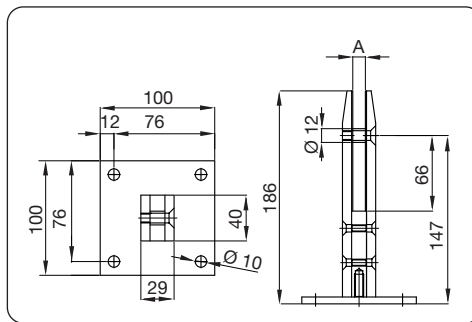

INFO
Glas und Metall sind durch EPDM-Schicht zu trennen. | Glass and metal must be separated by an epdm washer.

| Art. Nr. item no. | Material material | A | Oberfläche finish | |
|----------------------|----------------------|------------|----------------------|---|
| 11 10 28 00 | V2A (1.4301) | 12 - 17,52 | Korn finish 240 | 1 |
| 10 55 66 00 | V4A | 12 - 17,52 | Korn finish 240 | 1 |



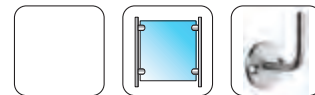

■ Inhalt | content

- Holzhandläufe | wooden handrails..... 134
- Fertigholzhandläufe | prefabricated wooden handrails..... 135
- Endkappen | end caps..... 136
- Verbinder für Holzhandläufe | wood connectors 137
- Holzhandlaufträger und Zubehör 139
supports for wooden handrails and accessories



INFO

Alle Holzhandläufe sind mit Klarlack endbehandelt. | All wooden handrails are finished with clear lacquer.



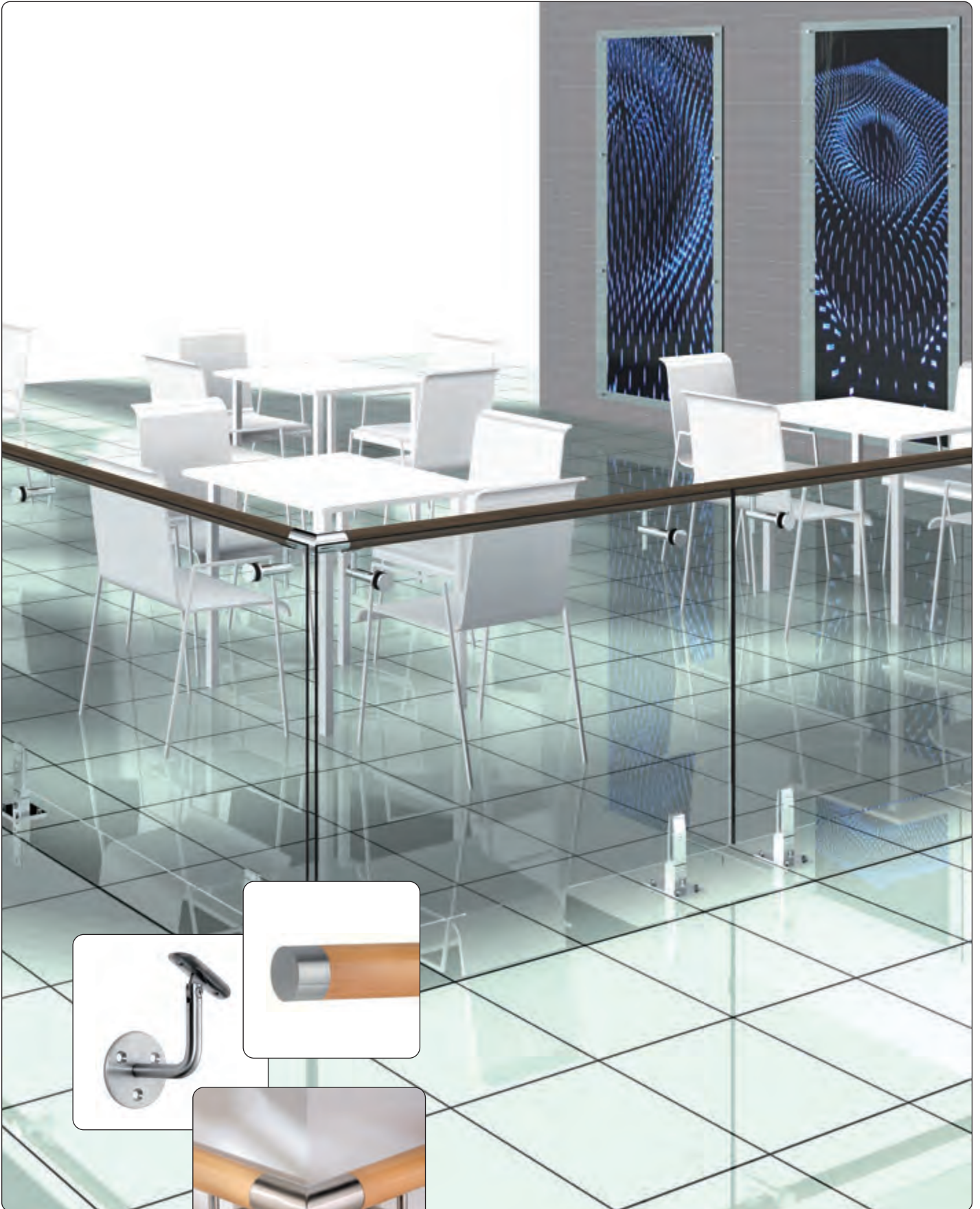

- Holzhandlaufsysteme
wooden handrail systems



- Holzhandlauf, Buche beschichtet
 wooden handrail, beech, treated



| Art. Nr. item no. | Ø | Länge length | Oberfläche finish |  |
|----------------------|----|-----------------|------------------------------------|--|
| 10 31 05 00 | 45 | 2000 | Buche beschichtet beech, treated | 1 |
| 10 31 06 00 | 45 | 3000 | Buche beschichtet beech, treated | 1 |

- Holzhandlauf, Wenge beschichtet
 wooden handrail, wenge, treated



| Art. Nr. item no. | Ø | Länge length | Oberfläche finish |  |
|----------------------|----|-----------------|------------------------------------|--|
| 10 31 07 00 | 45 | 2000 | Wenge beschichtet wenge, treated | 1 |
| 10 31 08 00 | 45 | 3000 | Wenge beschichtet wenge, treated | 1 |

- Holzhandlauf, Natur unbehandelt
 wooden handrail, natural, untreated



| Art. Nr. item no. | Ø | Länge length | Oberfläche finish |  |
|----------------------|----|-----------------|--|--|
| 10 31 09 00 | 45 | 2000 | Natur unbehandelt natural, untreated | 1 |
| 10 31 10 00 | 45 | 3000 | Natur unbehandelt natural, untreated | 1 |





- Holzhandlaufset, Buche beschichtet
 wooden handrail set, beech, treated



| Art. Nr. item no. | Ø | Länge length | Oberfläche finish | |
|----------------------|----|-----------------|------------------------------------|---|
| 10 31 11 00 | 45 | 2000 | Buche beschichtet beech, treated | 1 |
| 10 31 12 00 | 45 | 3000 | Buche beschichtet beech, treated | 1 |

- Holzhandlaufset, Wenge beschichtet
 wooden handrail set, wenge, treated



| Art. Nr. item no. | Ø | Länge length | Oberfläche finish | |
|----------------------|----|-----------------|------------------------------------|---|
| 10 31 13 00 | 45 | 2000 | Wenge beschichtet wenge, treated | 1 |
| 10 31 14 00 | 45 | 3000 | Wenge beschichtet wenge, treated | 1 |

- Holzhandlaufset, Natur unbehandelt
 wooden handrail set, natural, untreated



| Art. Nr. item no. | Ø | Länge length | Oberfläche finish | |
|----------------------|----|-----------------|--|---|
| 10 31 15 00 | 45 | 2000 | Natur unbehandelt natural, untreated | 1 |
| 10 31 16 00 | 45 | 3000 | Natur unbehandelt natural, untreated | 1 |

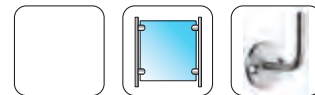

- Bohrlehre für Holzhandläufe Ø 45 mm
jig for wooden handrails Ø 45 mm

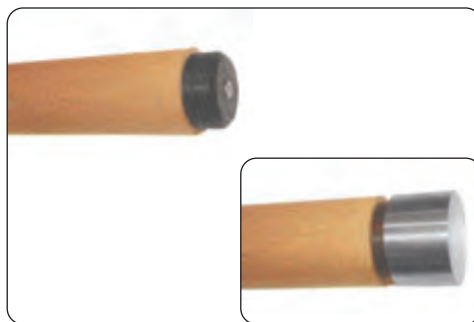

| Art. Nr. item no. | Material material | Ø | |
|----------------------|----------------------|----|---|
| 10 31 02 00 | Aluminium | 45 | 1 |

- Endkappe flach für Holzhandläufe
end cap flat, for wooden handrails



| Art. Nr. item no. | Material material | Ø | ± | Oberfläche finish | |
|----------------------|----------------------|----|---|----------------------|---|
| 10 30 70 00 | V2A (1.4301) | 45 | 3 | Korn finish 240 | 2 |

- Endkappe rund für Holzhandläufe
end cap round, for wooden handrails

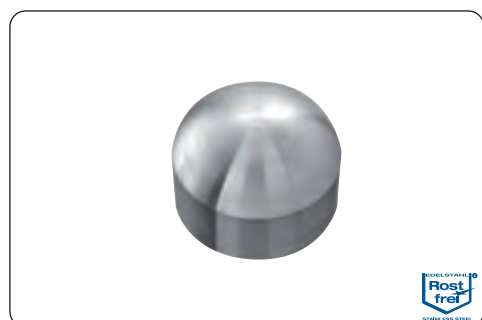

| Art. Nr. item no. | Material material | Ø | ± | Oberfläche finish | |
|----------------------|----------------------|----|---|----------------------|---|
| 10 30 69 00 | V2A (1.4301) | 45 | 3 | Korn finish 240 | 2 |





■ T-Stück für Holzhandläufe
T-connector for wooden handrails



| Art. Nr. item no. | Material material | Ø | für Ø for Ø | ÷ | Oberfläche finish | |
|----------------------|----------------------|------------|----------------|---|----------------------|---|
| 10 30 64 00 | V2A (1.4301) | 42,4 x 2,0 | 45 | 3 | Korn finish 240 | 1 |

■ Verbinder für Holzhandläufe 180°
connector for wooden handrails 180°



| Art. Nr. item no. | Material material | für Ø for Ø | ÷ | Oberfläche finish | |
|----------------------|----------------------|----------------|---|----------------------|---|
| 10 30 66 00 | V2A (1.4301) | 45 | 3 | Korn finish 240 | 2 |

■ Verbinder für Holzhandläufe 90°, eckig
connector for wooden handrails 90°, square



| Art. Nr. item no. | Material material | für Ø for Ø | ÷ | Oberfläche finish | |
|----------------------|----------------------|----------------|---|----------------------|---|
| 10 30 60 00 | V2A (1.4301) | 45 | 3 | Korn finish 240 | 2 |

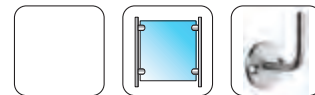

- Verbinder für Holzhandläufe 90°, rund**
 connector for wooden handrails 90°, round



| Art. Nr. item no. | Material material | für Ø for Ø | ⊕ | Oberfläche finish | |
|----------------------|----------------------|----------------|---|----------------------|---|
| 10 30 61 00 | V2A (1.4301) | 45 | 3 | Korn finish 240 | 2 |

- Verbinder für Holzhandläufe, stufenlos verdrehbar**
 connector for wooden handrails, infinitely adjustable



| Art. Nr. item no. | Material material | für Ø for Ø | ⊕ | Oberfläche finish | |
|----------------------|----------------------|----------------|---|----------------------|---|
| 10 30 62 00 | V2A (1.4301) | 45 | 3 | Korn finish 240 | 1 |

- Verbindungsgelenk für Holzhandläufe, min. 90°**
 connecting joint for wooden handrails, min. 90°



| Art. Nr. | Material material | für Ø for Ø | ⊕ | Oberfläche finish | |
|-------------|----------------------|----------------|---|----------------------|---|
| 10 31 00 00 | V2A (1.4301) | 45 | 3 | Korn finish 240 | 1 |





Montageset
assembly set



| Art. Nr. item no. | ⊕ | 📄 |
|----------------------|----|----|
| 10 31 03 00 | M6 | 10 |

Kunststoffadapterstück
plastic adapter



| Art. Nr. item no. | ∅ | 📄 |
|----------------------|----|---|
| 10 31 01 00 | 39 | 1 |

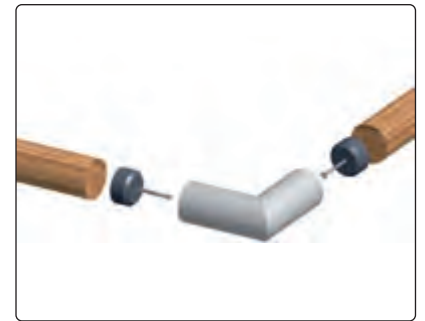

Handlaufträger mit Innengewinde
handrail support with internal thread

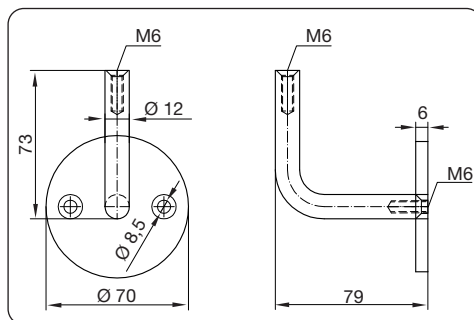
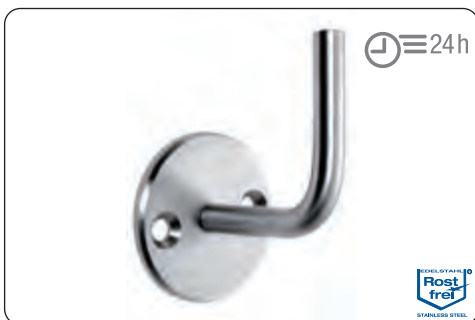

| Art. Nr. item no. | Material material | Oberfläche finish | 📄 |
|----------------------|----------------------|----------------------|---|
| 10 00 27 00 | V2A (1.4301) | Korn finish 240 | 2 |

Handlaufträger starr, gelasert
handrail support rigid, laser cut

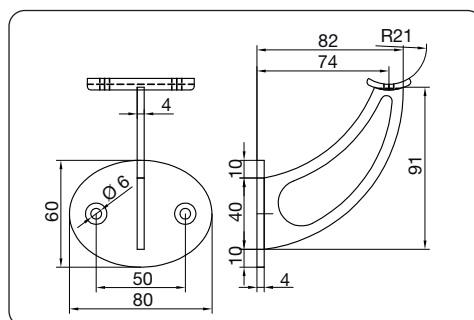

| Art. Nr. item no. | Material material | Aufnahme adapter | Oberfläche finish | 📄 |
|----------------------|----------------------|---------------------|----------------------|---|
| 10 10 37 00 | V2A (1.4301) | 33,7 - 42,4 | Korn finish 240 | 2 |

INFO
Unsere Handlaufträger finden Sie auf Seite 82. | You can find our handrail supports on page 82



■ Inhalt | content

- Querstabhalter | cross bar holders 142
- Blech- und Punkthalter | sheet holders and point fixings 147
- Edelstahlkugeln | stainless steel balls 148



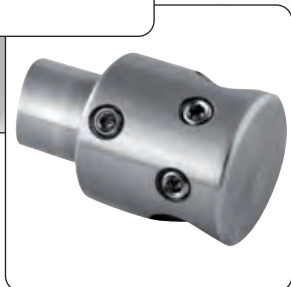
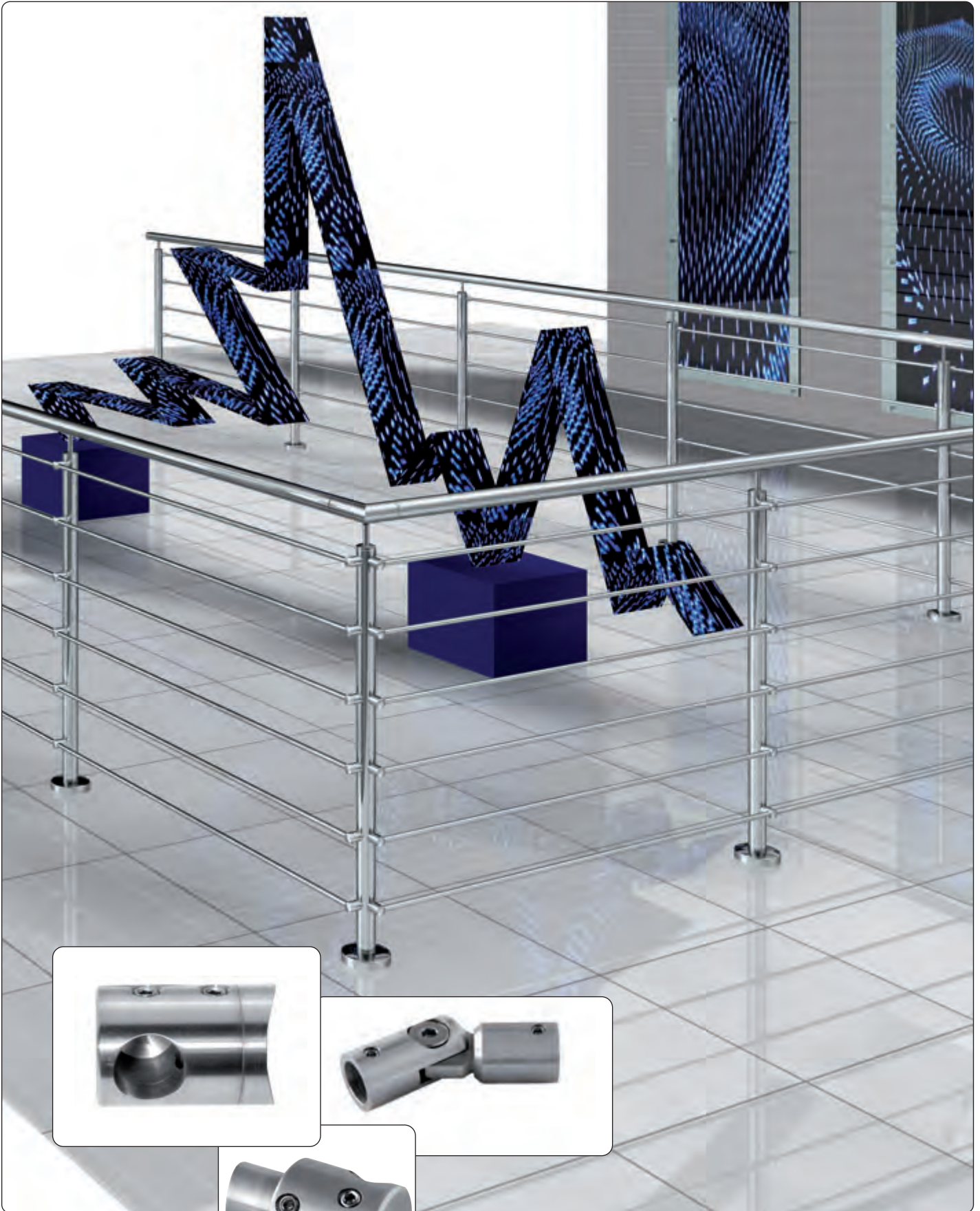

■ Geländersystemteile
balustrade system components



■ Querstabhalter mit Durchgangsbohrung
cross bar holder with through hole

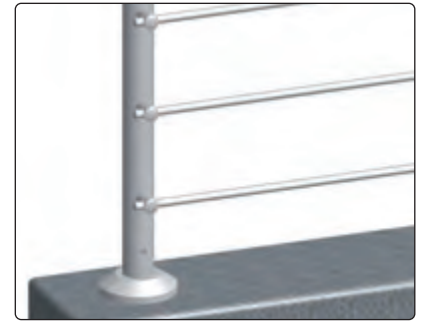
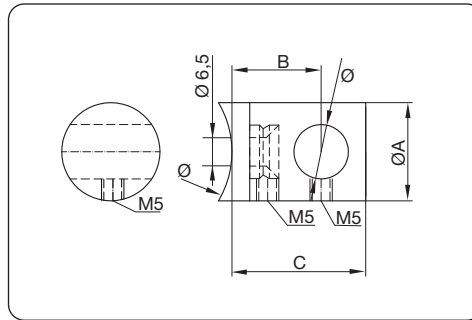

| Art. Nr. item no. | Material material | Ø | B | C | ØA | für Rohr for tube | Oberfläche finish | |
|----------------------|----------------------|------|----|----|----|----------------------|----------------------|---|
| 10 40 02 00 | V2A (1.4301) | 10,2 | 20 | 30 | 22 | Ø 33,7 | Korn finish 240 | 4 |
| 10 40 76 00 | V2A (1.4301) | 10,2 | 20 | 30 | 22 | Ø 42,4 | Korn finish 240 | 4 |
| 10 40 03 00 | V2A (1.4301) | 10,2 | 20 | 30 | 22 | □ | Korn finish 240 | 4 |
| 10 55 12 00 | V4A | 10,2 | 20 | 30 | 22 | Ø 33,7 | Korn finish 240 | 4 |
| 10 55 13 00 | V4A | 10,2 | 20 | 30 | 22 | □ | Korn finish 240 | 4 |
| 10 40 18 00 | V2A (1.4301) | 12,2 | 20 | 30 | 22 | Ø 33,7 | Korn finish 240 | 4 |
| 10 40 00 00 | V2A (1.4301) | 12,2 | 20 | 30 | 22 | Ø 42,4 | Korn finish 240 | 4 |
| 10 40 01 00 | V2A (1.4301) | 12,2 | 20 | 30 | 22 | □ | Korn finish 240 | 4 |
| 10 40 39 00 | V4A | 12,2 | 20 | 30 | 22 | Ø 33,7 | Korn finish 240 | 4 |
| 10 55 14 00 | V4A | 12,2 | 20 | 30 | 22 | Ø 42,4 | Korn finish 240 | 4 |
| 10 55 15 00 | V4A | 12,2 | 20 | 30 | 22 | □ | Korn finish 240 | 4 |
| 10 40 66 00 | V2A (1.4301) | 16,2 | 25 | 36 | 24 | Ø 42,4 | Korn finish 240 | 4 |

■ Querstabhalter mit Sacklochbohrung
cross bar holder with blind hole

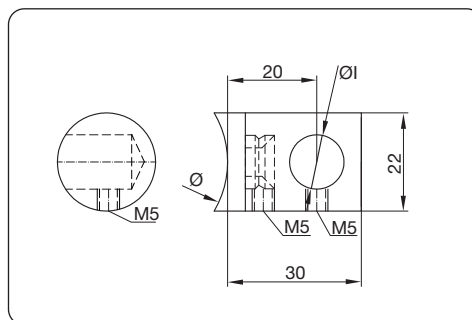

| Art. Nr. item no. | Material material | Anschluss adapter | ØI | für Rohr for tube | Oberfläche finish | |
|----------------------|----------------------|----------------------|------|----------------------|----------------------|---|
| 10 40 04 00 | V2A (1.4301) | L | 12,2 | Ø 42,4 | Korn finish 240 | 4 |
| 10 40 05 00 | V2A (1.4301) | R | 12,2 | Ø 42,4 | Korn finish 240 | 4 |
| 10 55 16 00 | V4A | L | 12,2 | Ø 42,4 | Korn finish 240 | 4 |
| 10 55 17 00 | V4A | R | 12,2 | Ø 42,4 | Korn finish 240 | 4 |





■ Querstabhalter mit Durchgangsbohrung
cross bar holder with through hole

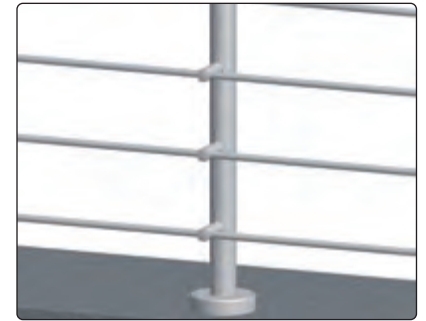
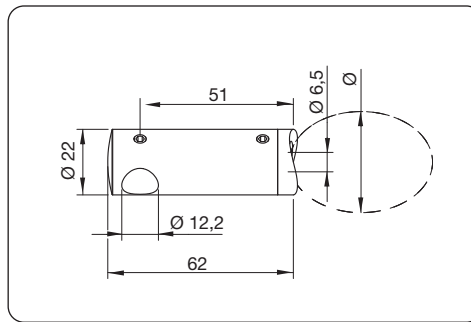

| Art. Nr. item no. | Material material | für Rohr for tube | Oberfläche finish | |
|----------------------|----------------------|----------------------|----------------------|---|
| 10 10 17 00 | V2A (1.4301) | Ø 42,4 | Korn finish 240 | 4 |
| 10 10 18 00 | V2A (1.4301) | □ | Korn finish 240 | 4 |

■ Querstabhalter gefräst für Flachstahlanschluss
cross bar holder for flat bar mounting

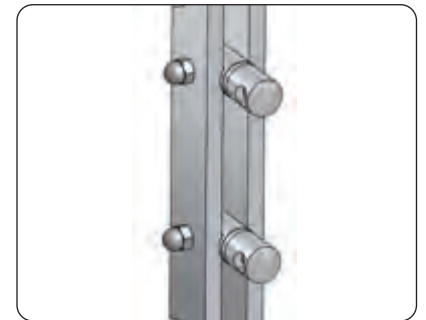
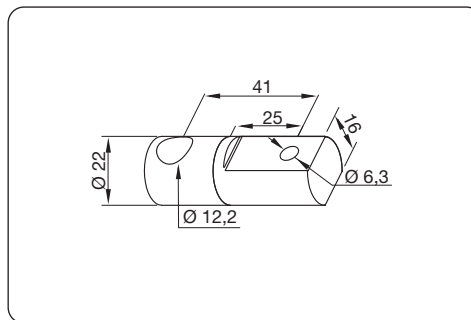

| Art. Nr. item no. | Material material | Oberfläche finish | |
|----------------------|----------------------|----------------------|---|
| 10 40 19 00 | V2A (1.4301) | Korn finish 240 | 4 |

■ Verbindungsstück 180°
connector 180°

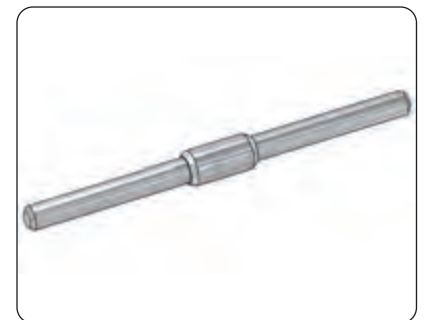
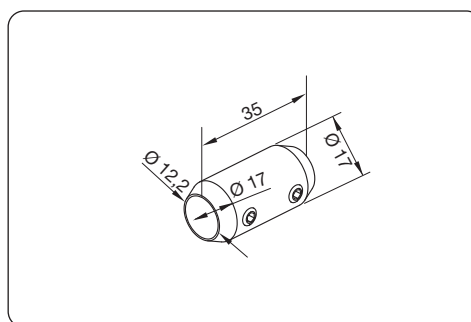

| Art. Nr. item no. | Material material | Oberfläche finish | |
|----------------------|----------------------|----------------------|---|
| 10 40 20 00 | V2A (1.4301) | Korn finish 240 | 4 |
| 10 40 40 00 | V4A | Korn finish 240 | 4 |

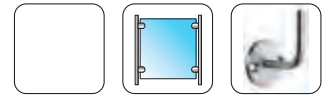

■ Querstabhalter für Stoßverbindungen
cross bar holders with through hole for butting

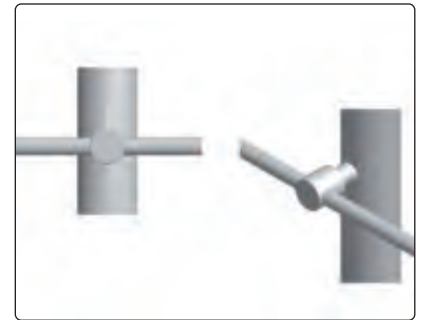
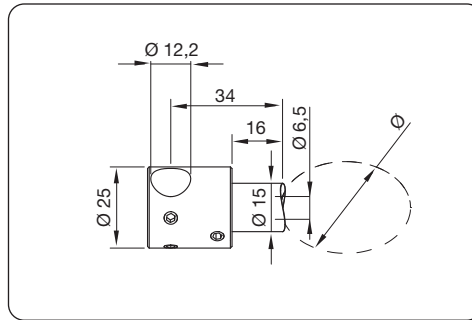
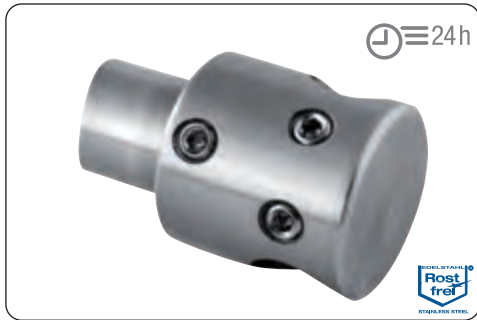

| Art. Nr. item no. | Material material | für Rohr for tube | Oberfläche finish | |
|----------------------|----------------------|----------------------|----------------------|---|
| 10 40 21 00 | V2A (1.4301) | Ø 42,4 | Korn finish 240 | 4 |

■ Querstabhalter stufenlos verdrehbar
cross bar holder, infinitely adjustable

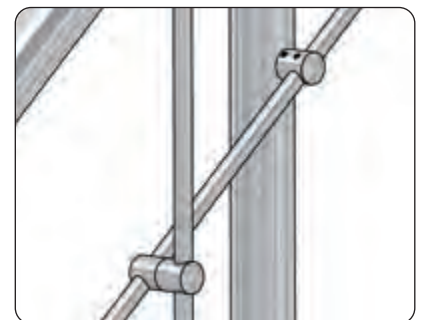
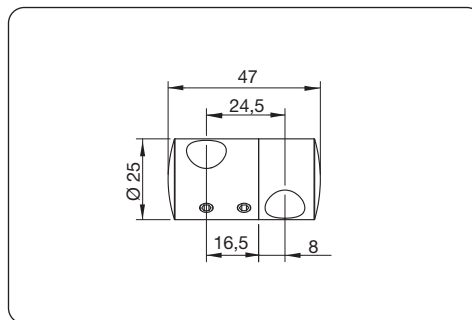

| Art. Nr. item no. | Material material | Ø | Oberfläche finish | |
|----------------------|----------------------|-------------|----------------------|---|
| 10 40 22 00 | V2A (1.4301) | 12,2 / 12,2 | Korn finish 240 | 4 |
| 10 40 23 00 | V2A (1.4301) | 14,2 / 12,2 | Korn finish 240 | 4 |

■ Querstabhalter mit Stiftschraube
cross bar holder with M6 fastening screw

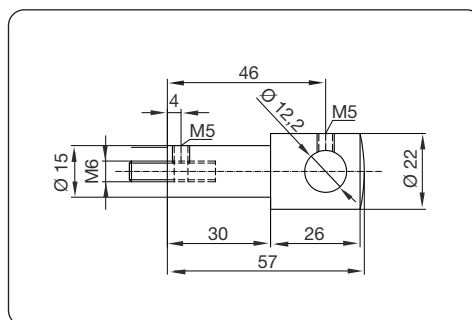

| Art. Nr. item no. | Material material | Ø | für Rohr for tube | Oberfläche finish | |
|----------------------|----------------------|------|----------------------|----------------------|---|
| 10 40 25 00 | V2A (1.4301) | 12,2 | □ | Korn finish 240 | 4 |





■ Querstabhalter 90°
cross bar holder 90°

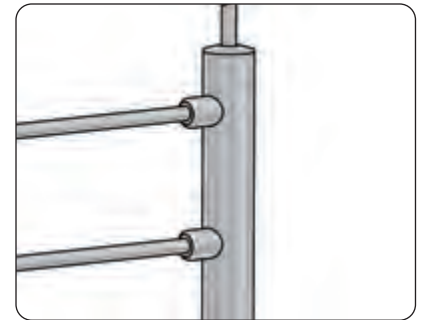
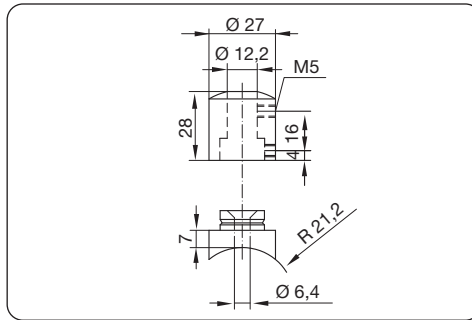

| Art. Nr. item no. | Material material | Ø | für Rohr for tube | Oberfläche finish | |
|----------------------|----------------------|------|----------------------|----------------------|---|
| 10 40 26 00 | V2A (1.4301) | 12,2 | Ø 42,4 | Korn finish 240 | 4 |
| 10 40 27 00 | V2A (1.4301) | 12,2 | □ | Korn finish 240 | 4 |

■ Gelenkstück 180°-90°
cross bar holder adjustable 180° - 90°

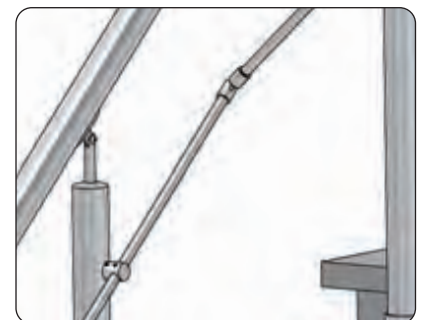
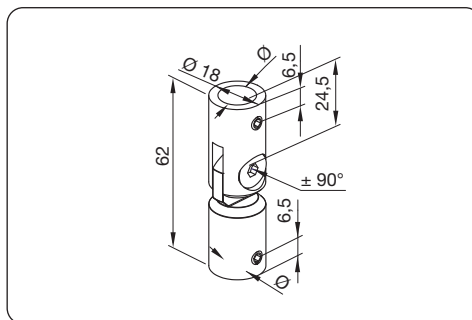

| Art. Nr. item no. | Material material | Ø | Oberfläche finish | |
|----------------------|----------------------|------|----------------------|---|
| 10 30 90 00 | V2A (1.4301) | 12,2 | Korn finish 240 | 2 |
| 10 31 20 00 | V4A | 12,2 | Korn finish 240 | 2 |

■ Verbindungsstück flexibel
cross bar holder bendable

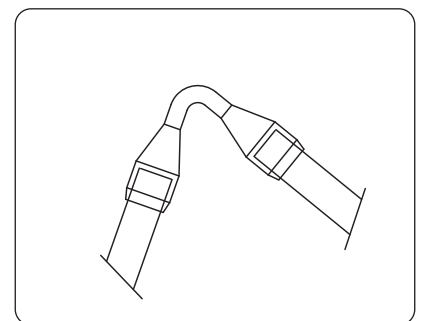
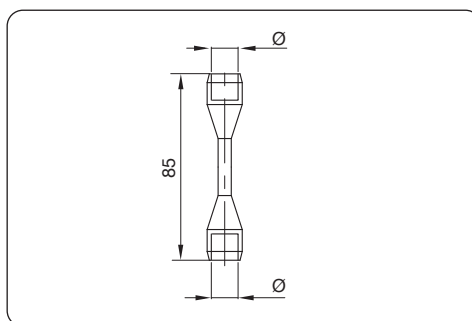

| Art. Nr. item no. | Material material | Ø | Oberfläche finish | |
|----------------------|----------------------|------|----------------------|---|
| 10 31 42 00 | V2A (1.4301) | 10,2 | Korn finish 240 | 4 |
| 10 31 43 00 | V2A (1.4301) | 12,2 | Korn finish 240 | 4 |
| 10 31 44 00 | V2A (1.4301) | 14,2 | Korn finish 240 | 4 |
| 10 56 06 00 | V4A | 10,2 | Korn finish 240 | 4 |
| 10 56 07 00 | V4A | 12,2 | Korn finish 240 | 4 |
| 10 56 08 00 | V4A | 14,2 | Korn finish 240 | 4 |



■ Querstabhalter mit Konterfunktion | cross bar holder for round tube with counter plate

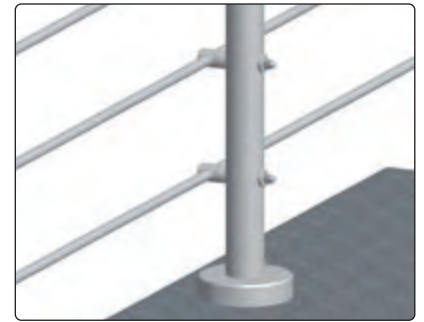
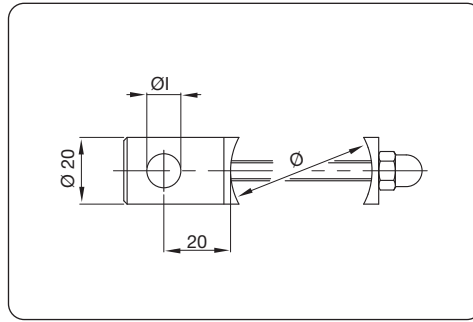
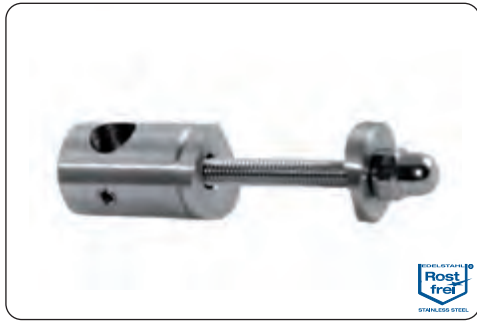

| Art. Nr. item no. | Material material | ØI | für Rohr for tube | Oberfläche finish | |
|----------------------|----------------------|------|----------------------|----------------------|---|
| 10 40 71 00 | V2A (1.4301) | 10,2 | Ø 33,7 | Korn finish 240 | 2 |
| 10 40 72 00 | V2A (1.4301) | 12,2 | Ø 33,7 | Korn finish 240 | 2 |
| 10 40 73 00 | V2A (1.4301) | 10,2 | Ø 42,4 | Korn finish 240 | 2 |
| 10 40 74 00 | V2A (1.4301) | 12,2 | Ø 42,4 | Korn finish 240 | 2 |
| 10 40 75 00 | V2A (1.4301) | 14,4 | Ø 42,4 | Korn finish 240 | 2 |

■ Querstabhalter mit Glasanschluss für Glasstärke 6-10,76mm | cross bar holder for glass mounting, G = 6-10.76 mm

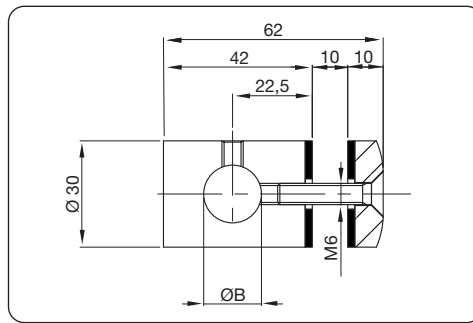

| Art. Nr. item no. | Material material | Ø | Oberfläche finish | | |
|----------------------|----------------------|----|----------------------|-------------------|---|
| 10 40 69 00 | V2A (1.4301) | M6 | 12,2 | Korn finish 240 | 2 |
| 10 40 68 00 | V2A (1.4301) | M6 | 14,2 | Korn finish 240 | 2 |
| 10 40 67 00 | V2A (1.4301) | M6 | 16,2 | Korn finish 240 | 2 |
| 10 55 60 00 | V4A | M6 | 12,2 | Korn finish 240 | 2 |
| 10 55 59 00 | V4A | M6 | 14,2 | Korn finish 240 | 2 |
| 10 55 58 00 | V4A | M6 | 16,2 | Korn finish 240 | 2 |

INFO

Glas und Metall sind durch EPDM-Schicht zu trennen. | Glass and metal must be separated by an epdm washer.

■ Querstabhalter 90°, Eckverbindung | cross bar holder for 90°, corners

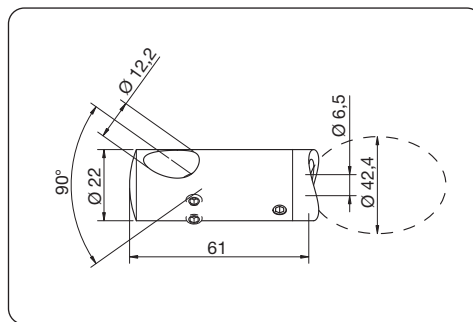

| Art. Nr. item no. | Material material | Ø | für Rohr for tube | Oberfläche finish | |
|----------------------|----------------------|------|----------------------|----------------------|---|
| 10 40 65 00 | V2A (1.4301) | 12,2 | Ø 42,4 | Korn finish 240 | 2 |





■ Plattenhalter
panel holder

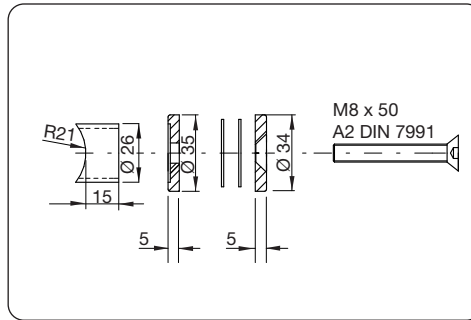
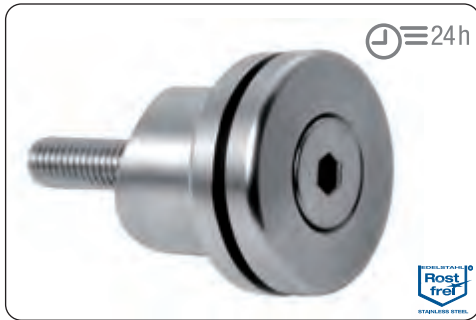

| Art. Nr. item no. | Material material | Ø | für Rohr for tube | Oberfläche finish | 2 |
|----------------------|----------------------|--------------------------|----------------------|----------------------|---|
| 10 90 07 00 | V2A (1.4301) | M8/Distanzhülse spacer | Ø 42,4 | Korn finish 240 | 2 |

INFO

Glas und Metall sind durch EPDM-Schicht zu trennen. | Glass and metal must be separated by an epdm washer.

■ Punkthalter erhaben
point fixing, raised head

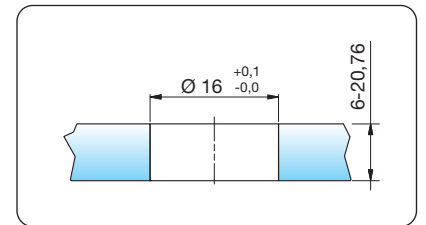
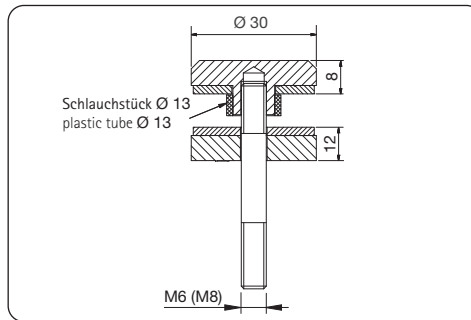

| Art. Nr. item no. | Material material | Ø | Oberfläche finish | 2 | |
|----------------------|----------------------|----|----------------------|---|---|
| 17 02 11 22 | V2A (1.4301) | M6 | 30 | Edelstahl geschliffen s. s. turned finish | 2 |
| 17 02 12 22 | V2A (1.4301) | M8 | 30 | Edelstahl geschliffen s. s. turned finish | 2 |
| 17 02 13 22 | V2A (1.4301) | M6 | 30 | Edelstahl geschliffen s. s. turned finish | 2 |
| 17 02 11 10 | V2A (1.4301) | M6 | 30 | poliert polished | 2 |
| 17 02 12 10 | V2A (1.4301) | M8 | 30 | poliert polished | 2 |
| 17 02 13 10 | V2A (1.4301) | M6 | 30 | poliert polished | 2 |

inklusive | includes

| | |
|-----------------|-----------|
| 170211_/170212_ | 170213_ |
| M6 (M8) x 60 mm | 6 x 60 mm |

Zubehör | accessories

17021400

■ Blechhalter
sheet holder

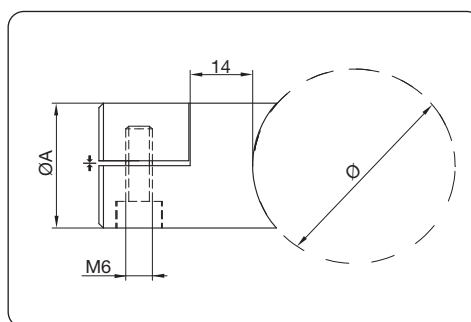

| Art. Nr. item no. | Material material | ± | für Rohr for tube | ØA | Oberfläche finish | 4 |
|----------------------|----------------------|-----|----------------------|----|----------------------|---|
| 10 90 25 00 | V2A (1.4301) | 1-2 | Ø 42,4 x 2,0 | 28 | Korn finish 240 | 4 |
| 10 90 26 00 | V2A (1.4301) | 1-2 | □ | 28 | Korn finish 240 | 4 |
| 10 31 35 00 | V2A (1.4301) | 1-4 | Ø 42,4 x 2,0 | 31 | Korn finish 240 | 4 |
| 10 31 36 00 | V2A (1.4301) | 1-4 | Ø 42,4 x 2,0 | 25 | Korn finish 240 | 4 |

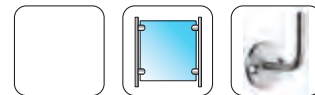

Edelstahlkugel
stainless steel ball

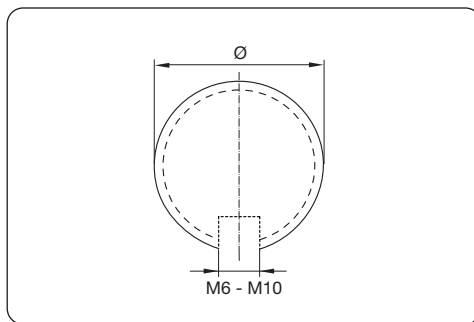

| Art. Nr. item no. | Material material | ⊙ | Ø | Oberfläche finish | 📦 |
|----------------------|----------------------|-----|-----|----------------------|---|
| 10 60 15 00 | V2A (1.4301) | M6 | 25 | Korn finish 320 | 2 |
| 10 60 16 00 | V2A (1.4301) | M6 | 30 | Korn finish 320 | 2 |
| 10 60 17 00 | V2A (1.4301) | M6 | 40 | Korn finish 320 | 2 |
| 10 60 18 00 | V2A (1.4301) | M8 | 50 | Korn finish 320 | 2 |
| 10 60 19 00 | V2A (1.4301) | M8 | 60 | Korn finish 320 | 2 |
| 10 60 20 00 | V2A (1.4301) | M8 | 70 | Korn finish 320 | 2 |
| 10 60 21 00 | V2A (1.4301) | M8 | 80 | Korn finish 320 | 2 |
| 10 60 22 00 | V2A (1.4301) | M10 | 100 | Korn finish 320 | 1 |
| 10 60 23 00 | V2A (1.4301) | M10 | 120 | Korn finish 320 | 1 |
| 10 60 24 00 | V2A (1.4301) | M10 | 150 | Korn finish 320 | 1 |
| 10 60 25 00 | V2A (1.4301) | M10 | 200 | Korn finish 320 | 1 |

Edelstahlkugel in Messingoptik
stainless steel ball, brass finish

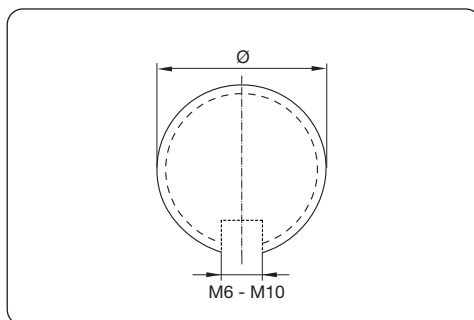

| Art. Nr. item no. | Material material | ⊙ | Ø | Oberfläche finish | 📦 |
|----------------------|----------------------|-----|-----|--|---|
| 10 60 30 00 | V2A (1.4301) | M6 | 30 | vergoldet, poliert gold plated, polished | 2 |
| 10 60 31 00 | V2A (1.4301) | M6 | 40 | vergoldet, poliert gold plated, polished | 2 |
| 10 60 32 00 | V2A (1.4301) | M6 | 50 | vergoldet, poliert gold plated, polished | 2 |
| 10 60 33 00 | V2A (1.4301) | M8 | 60 | vergoldet, poliert gold plated, polished | 2 |
| 10 60 34 00 | V2A (1.4301) | M8 | 80 | vergoldet, poliert gold plated, polished | 2 |
| 10 60 35 00 | V2A (1.4301) | M10 | 100 | vergoldet, poliert gold plated, polished | 1 |
| 10 60 36 00 | V2A (1.4301) | M10 | 120 | vergoldet, poliert gold plated, polished | 1 |





■ **Massivkugel mit Sacklochbohrung**
stainless steel ball, with blind hole, solid

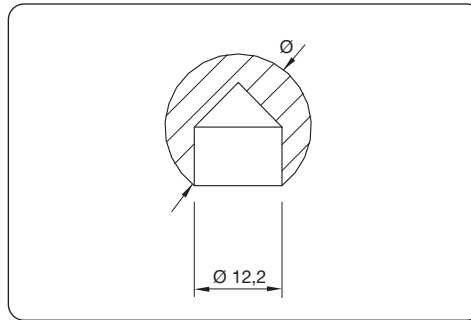

| Art. Nr. item no. | Material material | Ø | Oberfläche finish | |
|----------------------|----------------------|----|----------------------|---|
| 10 60 08 00 | V2A (1.4301) | 20 | Korn finish 240 | 4 |
| 10 60 11 00 | V2A (1.4301) | 25 | Korn finish 240 | 4 |
| 10 60 12 00 | V2A (1.4301) | 30 | Korn finish 240 | 4 |

■ **Massivkugel mit Durchgangsbohrung**
stainless steel ball, with through hole, solid

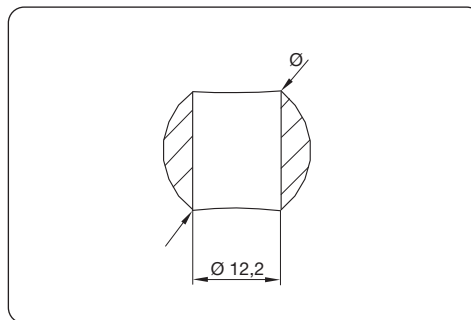

| Art. Nr. item no. | Material material | Ø | Oberfläche finish | |
|----------------------|----------------------|----|----------------------|---|
| 10 60 13 00 | V2A (1.4301) | 25 | Korn finish 240 | 4 |
| 10 60 10 00 | V2A (1.4301) | 30 | Korn finish 240 | 4 |

■ **Edelstahl-Gewindeadapter**
stainless steel threaded adapter

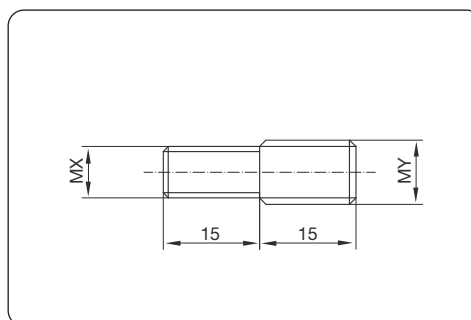

| Art. Nr. item no. | Material material | MX/MY | |
|----------------------|----------------------|--------|---|
| 14 20 36 00 | V2A (1.4301) | M6/M8 | 4 |
| 14 20 37 00 | V2A (1.4301) | M8/M10 | 4 |

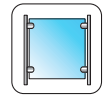
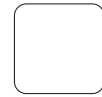

■ Inhalt | content



- Endkappen | end caps 152
- Handlaufträger | handrail supports 153
- Rohrverbinder | tube connectors 156
- Geländerpfostenhalter | post wall mounts 161
- Querstabhalter | cross bar holders 162





- Geländersystemteile poliert
balustrade system components polished

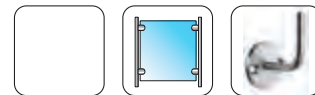

- Endkappe flach, massiv
end cap flat, solid

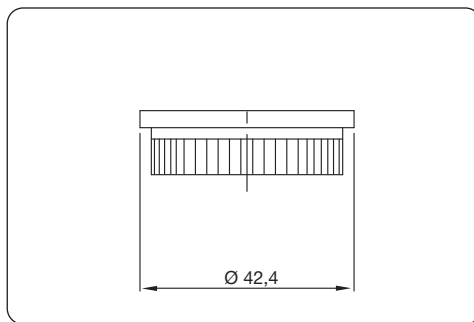

| Art. Nr. item no. | Material material | für Rohr Ø for tube Ø | Oberfläche finish | |
|----------------------|----------------------|--------------------------|----------------------|---|
| 10 55 99 00 | V4A | 42,4 x 2,0 | poliert polished | 2 |

- Endkappe oval, massiv
end cap oval, solid

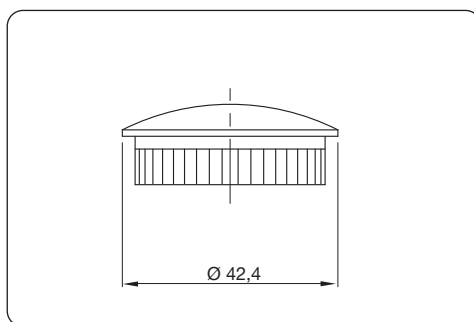

| Art. Nr. item no. | Material material | für Rohr Ø for tube Ø | Oberfläche finish | |
|----------------------|----------------------|--------------------------|----------------------|---|
| 10 55 98 00 | V4A | 42,4 x 2,0 | poliert polished | 2 |

- Endkappe rund, massiv
end cap round, solid

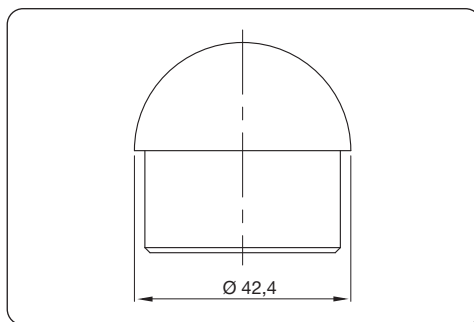

| Art. Nr. item no. | Material material | für Rohr Ø for tube Ø | Oberfläche finish | |
|----------------------|----------------------|--------------------------|----------------------|---|
| 10 55 97 00 | V4A | 42,4 x 2,0 | poliert polished | 2 |





■ Handlaufträger starr
handrail support rigid

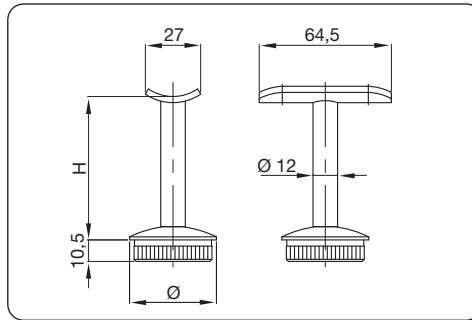

| Art. Nr. item no. | Material material | für Rohr Ø for tube Ø | H | Aufnahme adapter | Oberfläche finish | |
|----------------------|----------------------|--------------------------|----|---------------------|----------------------|---|
| 10 55 85 00 | V4A | 42,4 x 2,0 | 75 | Ø 33,7 - 42,4 | poliert polished | 2 |

■ Handlaufträger starr, massiv
handrail support rigid, massive

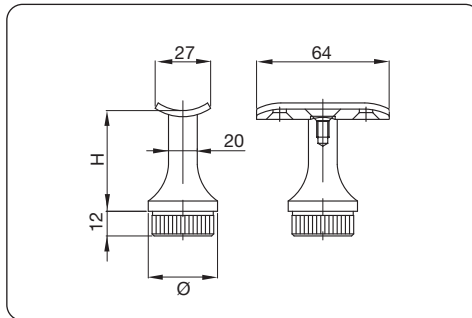

| Art. Nr. item no. | Material material | für Rohr Ø for tube Ø | H | Aufnahme adapter | Oberfläche finish | |
|----------------------|----------------------|--------------------------|----|---------------------|----------------------|---|
| 10 55 87 00 | V4A | 42,4 x 2,0 | 58 | Ø 33,7 - 42,4 | poliert polished | 2 |





- Handlaufträger variabel, massiv
handrail support variable, solid

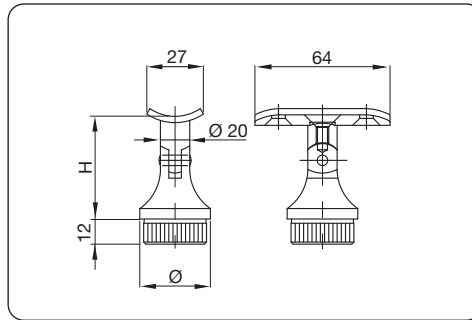

| Art. Nr. item no. | Material material | für Rohr Ø for tube Ø | H | Aufnahme adapter | Oberfläche finish | |
|----------------------|----------------------|--------------------------|----|---------------------|----------------------|---|
| 10 55 88 00 | V4A | 42,4 x 2,0 | 58 | Ø 33,7 - 42,4 | poliert polished | 2 |

- Handlaufträger variabel
handrail support variable

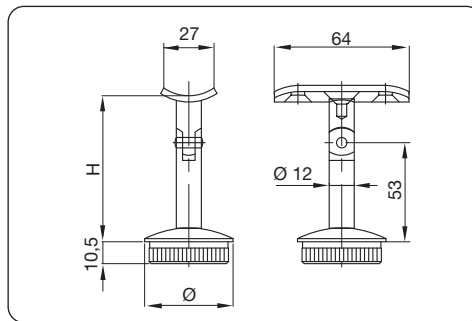

| Art. Nr. item no. | Material material | für Rohr Ø for tube Ø | H | Aufnahme adapter | Oberfläche finish | |
|----------------------|----------------------|--------------------------|----|---------------------|----------------------|---|
| 10 55 86 00 | V4A | 42,4 x 2,0 | 75 | Ø 33,7 - 42,4 | poliert polished | 2 |





Handlaufträger starr
handrail support rigid

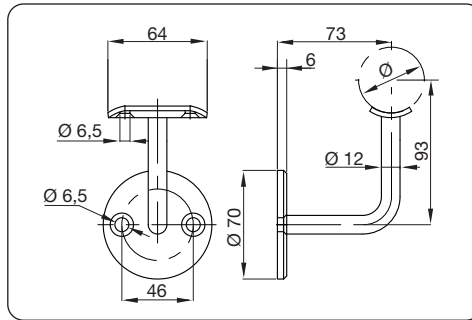

| Art. Nr. item no. | Material material | Ø | Oberfläche finish | |
|----------------------|----------------------|-------------|----------------------|---|
| 10 55 84 00 | V4A | 33,7 - 42,4 | poliert polished | 2 |

Handlaufträger variabel
handrail support variable

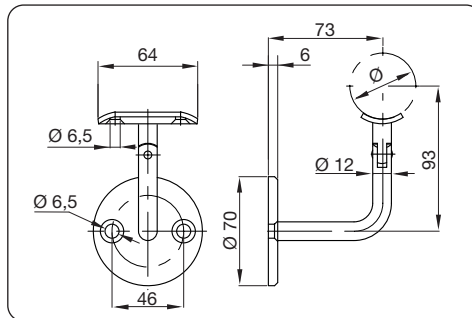

| Art. Nr. item no. | Material material | Ø | Oberfläche finish | |
|----------------------|----------------------|-------------|----------------------|---|
| 10 55 83 00 | V4A | 33,7 - 42,4 | poliert polished | 2 |

Kugelring
ball ring

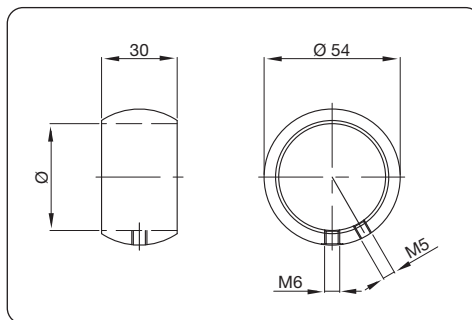

| Art. Nr. item no. | Material material | für Rohr Ø for tube Ø | Oberfläche finish | |
|----------------------|----------------------|--------------------------|----------------------|---|
| 10 55 90 00 | V4A | 42,4 | poliert polished | 2 |

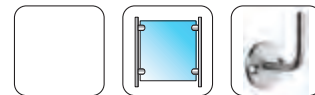

- Rohrverbinder 90°, rund
tube connector 90°, round

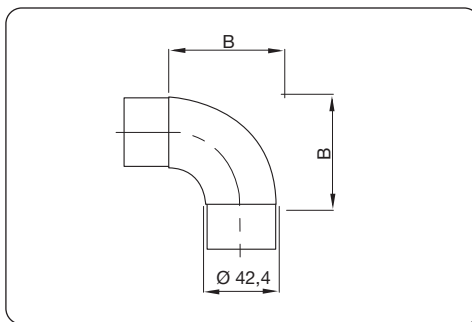

| Art. Nr. item no. | Material material | für Rohr Ø for tube Ø | B | Oberfläche finish | |
|----------------------|----------------------|--------------------------|----|----------------------|---|
| 10 55 91 00 | V4A | 42,4 x 2,0 | 65 | poliert polished | 2 |

- Rohrverbinder 90°, eckig
tube connector 90°, square

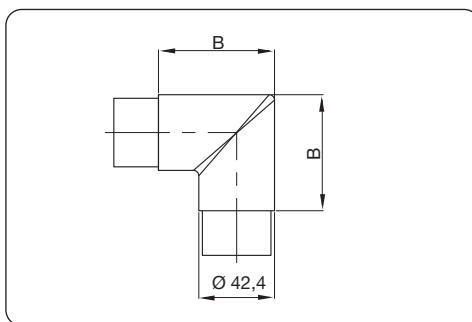

| Art. Nr. item no. | Material material | für Rohr Ø for tube Ø | B | Oberfläche finish | |
|----------------------|----------------------|--------------------------|----|----------------------|---|
| 10 55 92 00 | V4A | 42,4 x 2,0 | 65 | poliert polished | 2 |





■ Rohrverbinder 180°
tube connector 180°

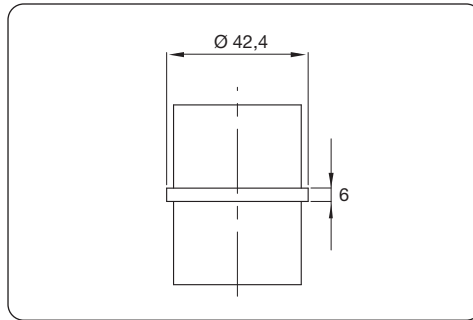

| Art. Nr. item no. | Material material | für Rohr Ø for tube Ø | Oberfläche finish | |
|----------------------|----------------------|--------------------------|----------------------|---|
| 10 55 96 00 | V4A | 42,4 x 2,0 | poliert polished | 2 |

■ T-Stück
T-connector

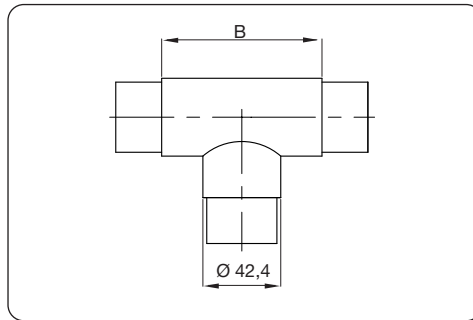

| Art. Nr. item no. | Material material | für Rohr Ø for tube Ø | B | Oberfläche finish | |
|----------------------|----------------------|--------------------------|----|----------------------|---|
| 10 55 95 00 | V4A | 42,4 x 2,0 | 87 | poliert polished | 1 |



■ Rohrverbinder mit Gelenk
tube connector with joint

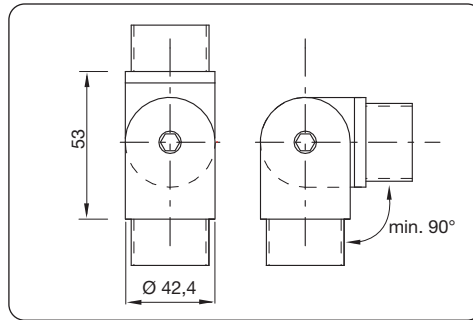

| Art. Nr. item no. | Material material | für Rohr Ø for tube Ø | Oberfläche finish | |
|----------------------|----------------------|--------------------------|----------------------|---|
| 10 55 93 00 | V4A | 42,4 x 2,0 | poliert polished | 1 |

■ Rohrverbinder stufenlos verdrehbar
tube connector, infinitely adjustable

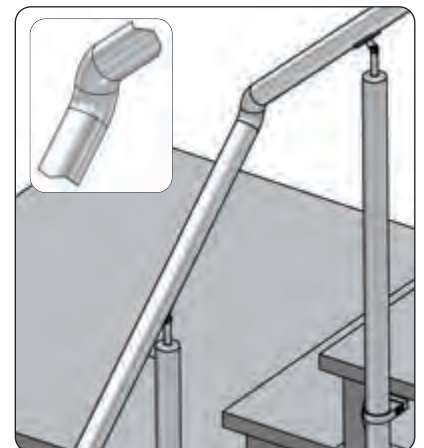
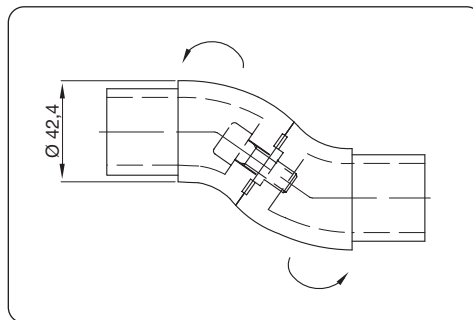

| Art. Nr. item no. | Material material | für Rohr Ø for tube Ø | Oberfläche finish | |
|----------------------|----------------------|--------------------------|----------------------|---|
| 10 55 94 00 | V4A | 42,4 x 2,0 | poliert polished | 1 |





- Rohrverbinder mit Flanschplatte, starr
tube connector with flange plate, rigid

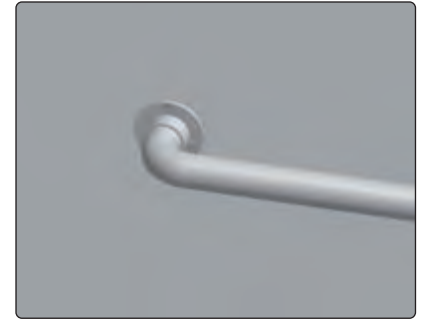
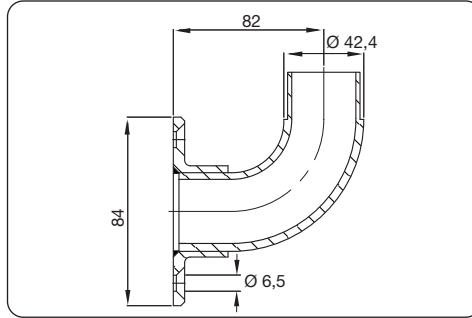

| Art. Nr. item no. | Material material | für Rohr Ø for tube Ø | Oberfläche finish | |
|----------------------|----------------------|--------------------------|----------------------|---|
| 10 55 80 00 | V4A | 42,4 x 2,0 | poliert polished | 1 |

- Rohrverbinder mit Flanschplatte, variabel
tube connector with flange plate, variable

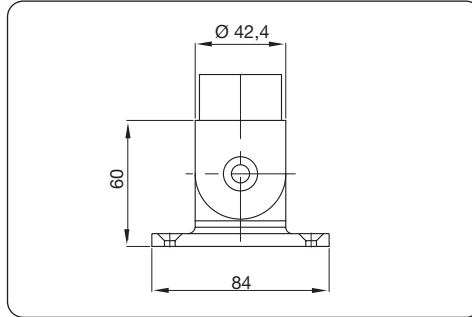

| Art. Nr. item no. | Material material | für Rohr Ø for tube Ø | Oberfläche finish | |
|----------------------|----------------------|--------------------------|----------------------|---|
| 10 55 81 00 | V4A | 42,4 x 2,0 | poliert polished | 1 |



■ Endbogen flach
end elbow flat

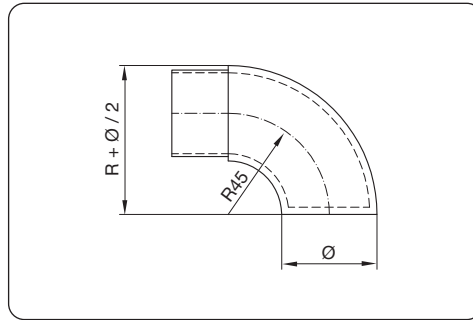

| Art. Nr. item no. | Material material | für Rohr Ø for tube Ø | Oberfläche finish | |
|----------------------|----------------------|--------------------------|----------------------|---|
| 10 56 00 00 | V4A | 42,4 x 2,0 | poliert polished | 1 |

■ Anschlussstück 90°
round tube adapter 90°

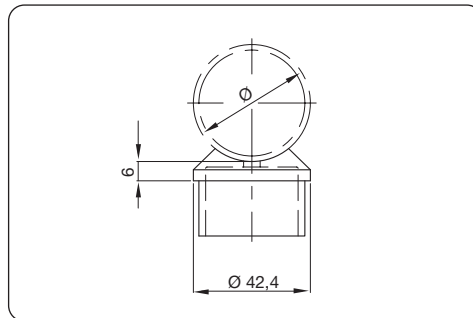

| Art. Nr. item no. | Material material | für Rohr Ø for tube Ø | Oberfläche finish | |
|----------------------|----------------------|--------------------------|----------------------|---|
| 10 55 89 00 | V4A | 42,4 x 2,0 | poliert polished | 2 |





Abdeckkrosette
cover plate

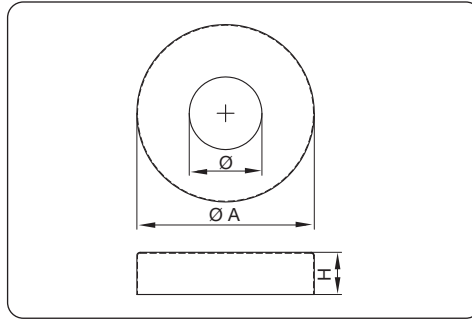

| Art. Nr. item no. | Material material | Ø | ØA | H | Oberfläche finish | |
|----------------------|----------------------|----|-----|----|----------------------|---|
| 10 55 77 00 | V4A | 43 | 105 | 15 | poliert polished | 2 |

Flanschplatte
flange plate

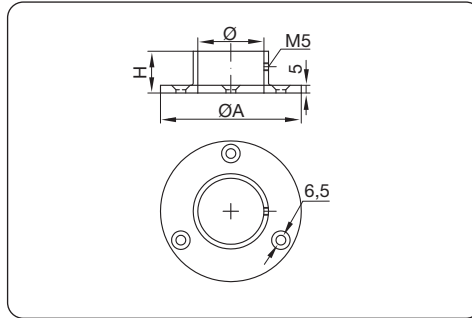

| Art. Nr. item no. | Material material | ØA | für Rohr Ø for tube Ø | H | Oberfläche finish | |
|----------------------|----------------------|----|--------------------------|----|----------------------|---|
| 10 55 79 00 | V4A | 85 | 42,4 | 25 | poliert polished | 2 |

Systempfostenplatte für Rundrohrpfosten
post wall mount adapter for round tube post

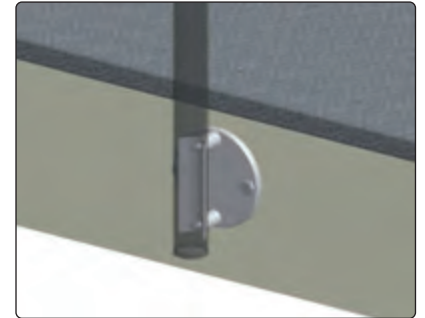
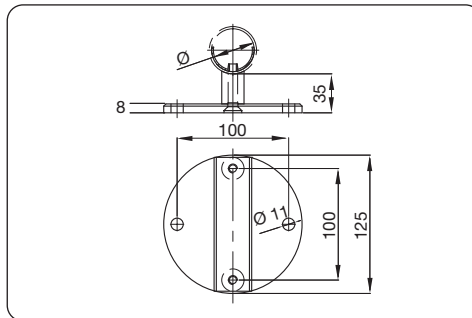

| Art. Nr. item no. | Material material | für Rohr Ø for tube Ø | Oberfläche finish | |
|----------------------|----------------------|--------------------------|----------------------|---|
| 10 55 82 00 | V4A | 42,4 | poliert polished | 1 |

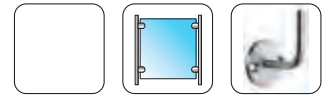

■ Querstabhalter mit Durchgangsbohrung
cross bar holder with through hole

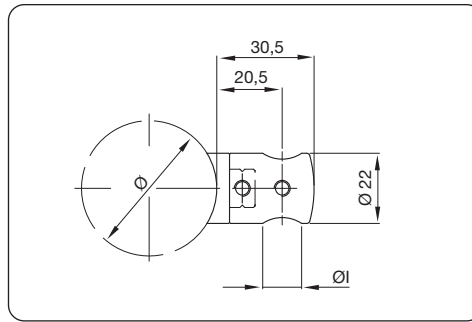

| Art. Nr. item no. | Material material | ØI | für Rohr for tube | Oberfläche finish | |
|----------------------|----------------------|------|----------------------|----------------------|---|
| 10 55 75 00 | V4A | 10,2 | Ø 42,4 | poliert polished | 4 |
| 10 55 74 00 | V4A | 12,2 | Ø 42,4 | poliert polished | 4 |

■ Stabhalter 90°
bar holder 90°

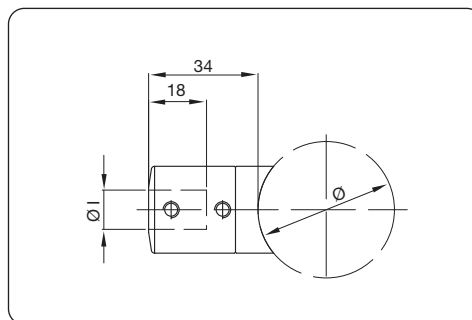

| Art. Nr. item no. | Material material | ØI | für Rohr for tube | Oberfläche finish | |
|----------------------|----------------------|------|----------------------|----------------------|---|
| 10 56 09 00 | V4A | 12,2 | Ø 42,4 | poliert polished | 4 |





■ Stabhalter variabel
bar holder variable

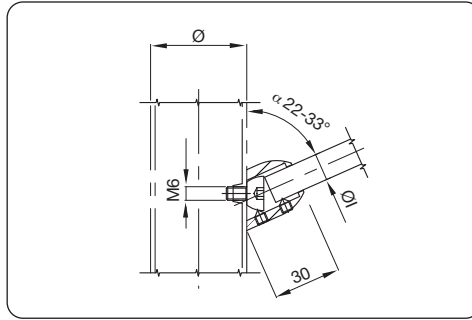

| Art. Nr. item no. | Material material | Ø | für Rohr for tube | Oberfläche finish | |
|----------------------|----------------------|------|----------------------|----------------------|---|
| 10 56 10 00 | V4A | 12,2 | Ø 42,4 | poliert polished | 4 |

■ Gelenkstück 180° - 90°
cross bar holder adjustable 180° - 90°

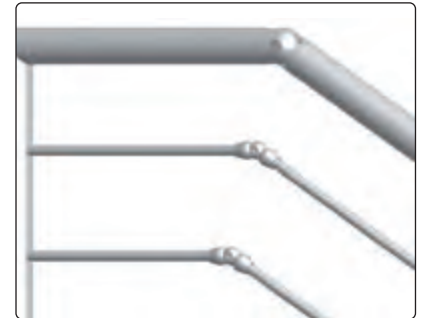
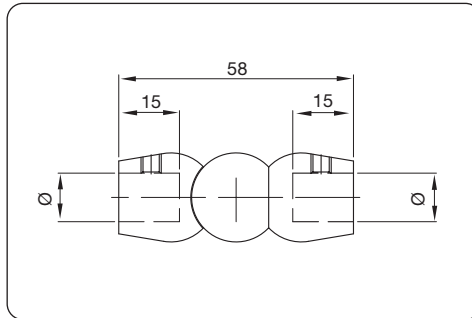

| Art. Nr. item no. | Material material | Ø | Oberfläche finish | |
|----------------------|----------------------|------|----------------------|---|
| 10 56 11 00 | V4A | 12,2 | poliert polished | 2 |

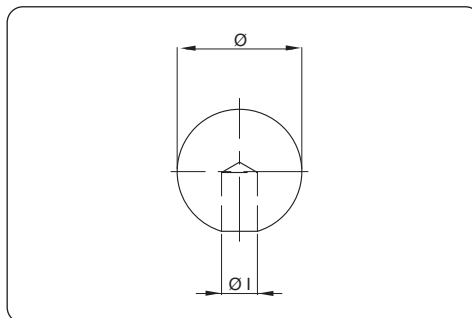

■ Massivkugel mit Sacklochbohrung
stainless steel ball with blind hole, solid



| Art. Nr. item no. | Material material | Ø | Ø1 | Oberfläche finish | |
|----------------------|----------------------|----|------|----------------------|---|
| 10 56 01 00 | V4A | 25 | 12,2 | poliert polished | 2 |
| 10 56 02 00 | V4A | 25 | 14,2 | poliert polished | 2 |

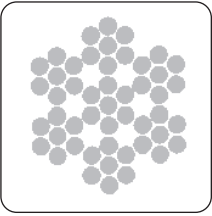

■ Inhalt | content

| | | | |
|--|---|-----|---|
|  | ■ Litzenseil stranded cable | 166 |  |
| | ■ Einseitig verpresste Seile single-sided pressed cables | 167 | |
| | ■ Beidseitig verpresste Seile double-sided pressed cables | 170 | |
| | ■ Längendefinitionen length definitions | 172 | |
| | ■ Spannelemente zur Selbstmontage tension elements | 173 | |
| | ■ Gabeln und Ösen forks and eyes | 174 | |
| | ■ Seilspanner turnbuckles | 177 | |
| | ■ Zubehör und Kleinteile accessories and small parts | 178 | |



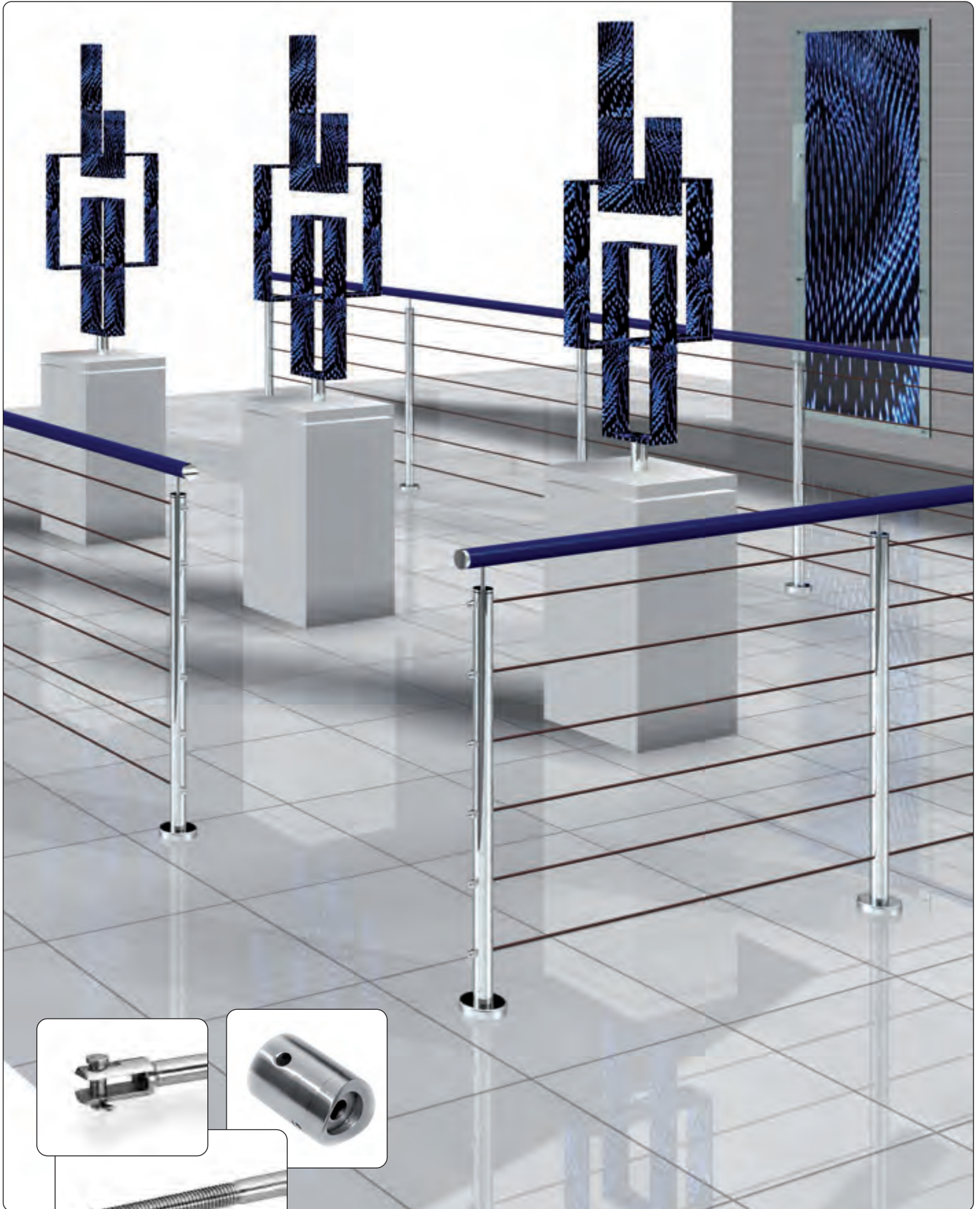

■ Seilsysteme
cable systems

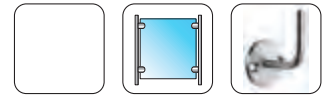

■ Litzenseil
stranded cable

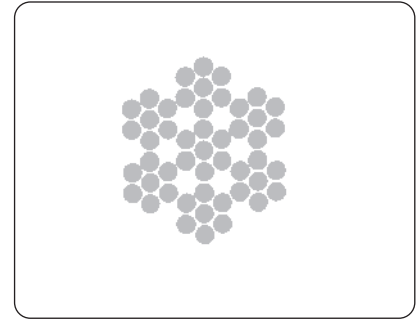

| Art. Nr. item no. | Seil Ø cable Ø | Anzahl Drähte no. of wires | rechnerische Bruchkraft calculated breaking strength | | Mindestbruchkraft minimum breaking strength | | Gewicht von 100 m in kg weight of 100 m in kg | lfm. m |
|----------------------|-------------------|-------------------------------|---|------|--|------|--|----------|
| | | | kN | t | kN | t | | |
| 12 00 00 00 | 4 | 6 x 7 / 42 | 10,9 | 1,11 | 9,1 | 0,93 | 5,5 | lfm. m |
| 12 00 01 00 | 5 | 6 x 7 / 42 | 16,0 | 1,63 | 13,0 | 1,33 | 8,4 | lfm. m |
| 12 00 02 00 | 6 | 6 x 7 / 42 | 24,0 | 2,45 | 19,0 | 1,94 | 13,0 | lfm. m |



■ Sicherheit

Um die Sicherheit einer Seilkonstruktion zu gewährleisten, muss vor der Seil- und Beschlagwahl die effektive Kraft, mit der das Drahtseil und der Endbeschlag belastet werden, bestimmt werden. Durch einen Sicherheitsfaktor – statische Anwendung Faktor 2-3 und dynamische Anwendung Faktor >5 – wird die zuverlässige Funktion gewährleistet.

■ Eigenschaften

Das hochfeste und flexible Drahtseil kann bei gleichem Durchmesser etwa die zweifache Last eines Stahlstabes aufnehmen. In Kombination mit verschiedenen Endbeschlägen erweist sich das Drahtseil als sehr vielseitiges Gestaltungselement bzw. Bauteil. Diese hochfesten Eigenschaften bleiben bei einer Einsatztemperatur von -50°C bis zu 250°C dauerhaft erhalten.

■ Seilaufbau

Drahtseile bestehen aus kaltgezogenen, hochfesten Drähten. Aus dem Grundelement Draht entsteht in einer ersten Verseilung die sogenannte Litze. In einer zweiten Verseilung werden mehrere Litzen um eine Einlage, zumeist auch eine Litze, zum Seil geschlagen.

■ Seilkräfte

Die Seilkraft bildet zusammen mit der Seilvorspannkraft die effektive Gesamtseilkraft. Sehr hohe Seilkräfte entstehen, wenn vertikale Kräfte auf ein horizontal gespanntes Seil wirken.

■ Safety

To ensure the safety of a cable construction, the effective force on the cable and end fitting must first be determined before the cable and fitting are selected. Reliable operation is ensured through the use of a safety factor – a static application factor of 2-3 and a dynamic application factor of >5.

■ Properties

The high-strength flexible cable can accommodate two times the load of a steel rod. In combination with various end fittings, the cables prove to be a very versatile design component. These high-strength values remain consistent between the temperatures of -50° C to 250° C.

■ Cable construction

Cables are made of cold drawn, high-strength wire. The basic wire element is initially braided into a "strand". In a second stranding, several strands are again braided around a core, usually also a strand, creating the cable.

■ Cable forces

The cable force and the prestressing force of the cable jointly represent the total effective cable force. Very high cable forces arise when vertical forces act on a horizontally tensioned cable.



- Außengewinde Fine Line, einseitig rundverpresst
external thread, round pressed from one side

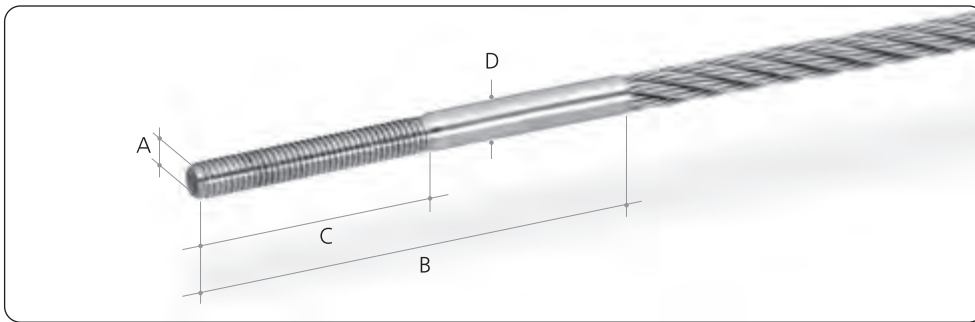

| Art. Nr. item no. | Seil Ø cable Ø | A | B | C | D | R/L | |
|----------------------|-------------------|----|-----|----|---|-----|---|
| 12 10 00 00 | 4 | M4 | 60 | 30 | 4 | R | 1 |
| 12 10 01 00 | 4 | M4 | 60 | 30 | 4 | L | 1 |
| 12 10 02 00 | 4 | M4 | 90 | 60 | 4 | R | 1 |
| 12 10 03 00 | 4 | M4 | 90 | 60 | 4 | L | 1 |
| 12 10 04 00 | 5 | M5 | 60 | 30 | 5 | R | 1 |
| 12 10 05 00 | 5 | M5 | 60 | 30 | 5 | L | 1 |
| 12 10 06 00 | 5 | M5 | 90 | 60 | 5 | R | 1 |
| 12 10 07 00 | 5 | M5 | 90 | 60 | 5 | L | 1 |
| 12 10 08 00 | 6 | M6 | 70 | 30 | 6 | R | 1 |
| 12 10 09 00 | 6 | M6 | 70 | 30 | 6 | L | 1 |
| 12 10 10 00 | 6 | M6 | 110 | 70 | 6 | R | 1 |
| 12 10 11 00 | 6 | M6 | 110 | 70 | 6 | L | 1 |

INFO

Der Preis beinhaltet das Gewindeterminale und die Arbeitskosten des Verpressens. Für den Endpreis müssen die lfm. pro Seil zugerechnet werden. | The price includes the threaded terminal and labour costs for the pressing. The unit price per metre of cabling must be added to find the final price.

Seile – konfektioniert oder zur Selbstmontage

In der Regel werden Seile fix auf Länge mit den entsprechenden Endverbindungen geliefert. Die Festlegung der Fertigungslängen bei verpressten Terminals sollte am fertigen Objekt geschehen. Die Selbstmontage-Spanner DO IT LINE haben den Vorteil, dass alle Seile vor Ort konfektioniert werden können. Das benötigte Seil erhalten Sie am Stück geliefert zum Selbst-Ablängen. Zu beachten ist, dass die Endverbindungen äußerst sorgfältig auf dem Seil montiert werden, damit die entsprechenden Zugkräfte garantiert werden können.

Cables – fully configured or for self-assembly

As a rule, cables are delivered in a fixed length with corresponding terminals. The manufacturing lengths with pressed terminals should be determined on the finished object. The benefit of the DO IT LINE tensioners for self-assembly is that all cables can be configured on site. The required cable is provided in a single piece and can be cut to suit your needs. It should be noted that the terminals must be mounted extremely carefully to the cable so that the corresponding tensile forces are ensured.



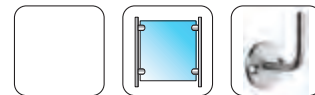

- Innengewinde Fine Line, einseitig rundverpresst**
 internal thread Fine Line, round pressed from one side

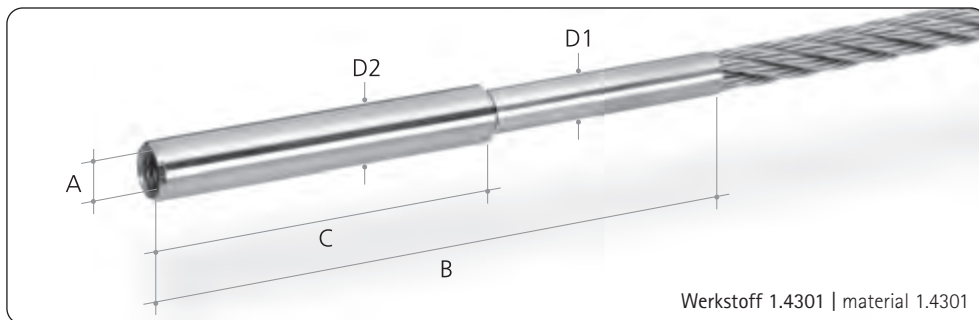

Werkstoff 1.4301 | material 1.4301



| Art. Nr. item no. | Seil Ø cable Ø | A | B | C | D1 | D2 | R/L | |
|----------------------|-------------------|----|----|----|----|----|-----|---|
| 12 10 40 00 | 4 | M4 | 60 | 30 | 4 | 6 | R | 1 |
| 12 10 41 00 | 5 | M5 | 70 | 35 | 5 | 7 | R | 1 |
| 12 10 42 00 | 6 | M6 | 85 | 45 | 6 | 8 | R | 1 |

- Linsenkopf Fine Line, einseitig rundverpresst**
 panhead Fine Line, round pressed from one side

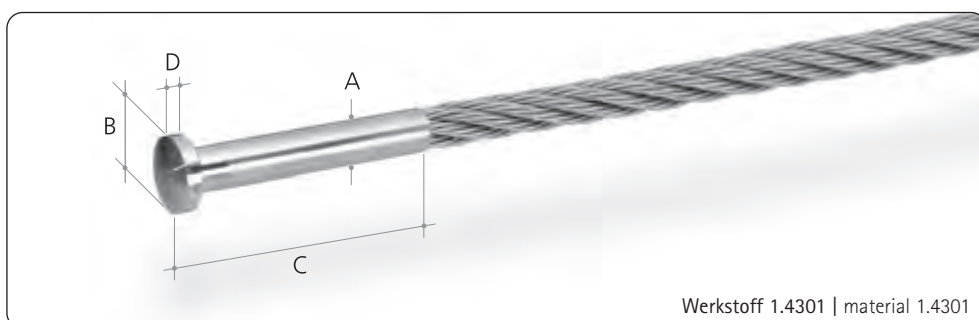

Werkstoff 1.4301 | material 1.4301



| Art. Nr. item no. | Seil Ø cable Ø | A | B | C | D | |
|----------------------|-------------------|---|----|----|---|---|
| 12 10 15 00 | 4 | 4 | 8 | 36 | 4 | 1 |
| 12 10 16 00 | 5 | 5 | 9 | 43 | 6 | 1 |
| 12 10 17 00 | 6 | 6 | 10 | 43 | 6 | 1 |

- Senkkopf Fine Line, einseitig rundverpresst**
 countersink head Fine Line, round pressed from one side

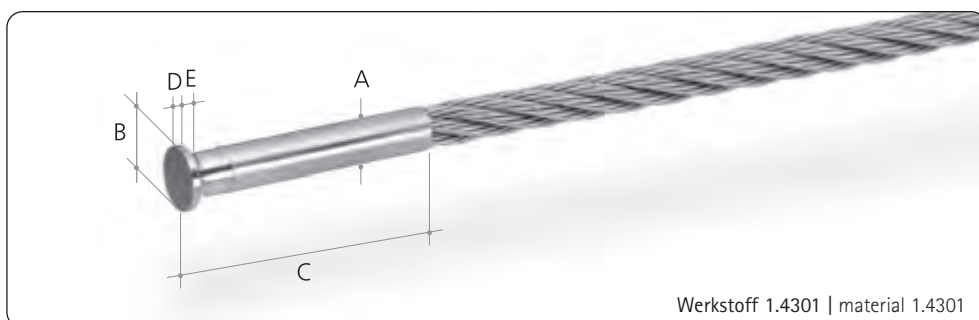

Werkstoff 1.4301 | material 1.4301



| Art. Nr. item no. | Seil Ø cables Ø | A | B | C | D | E | |
|----------------------|--------------------|---|-----|----|-----|------|---|
| 12 10 12 00 | 4 | 4 | 5,2 | 40 | 1,2 | 0,6 | 1 |
| 12 10 13 00 | 5 | 5 | 7,5 | 45 | 1,2 | 1,15 | 1 |
| 12 10 14 00 | 6 | 6 | 7,5 | 50 | 1,2 | 0,75 | 1 |





■ Gabel Fine, einseitig sechskantverpresst
fork Fine, hex pressed from one side

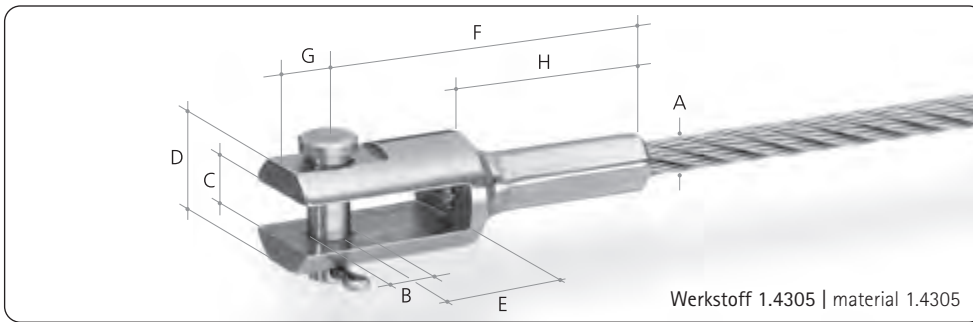

| Art. Nr. item no. | Seil Ø cable Ø | A | B | C | D | E | F | G | H | |
|----------------------|-------------------|---|-----|-----|----|------|------|-----|----|---|
| 12 10 18 00 | 4 | 4 | 4,5 | 5,5 | 11 | 13,5 | 40,5 | 5,5 | 27 | 1 |
| 12 10 19 00 | 5 | 5 | 6,0 | 6,5 | 14 | 18,0 | 46,0 | 7,0 | 28 | 1 |
| 12 10 20 00 | 6 | 6 | 6,0 | 6,5 | 14 | 18,0 | 46,0 | 7,0 | 28 | 1 |

■ Schlaufe mit Kausche
loop with thimble

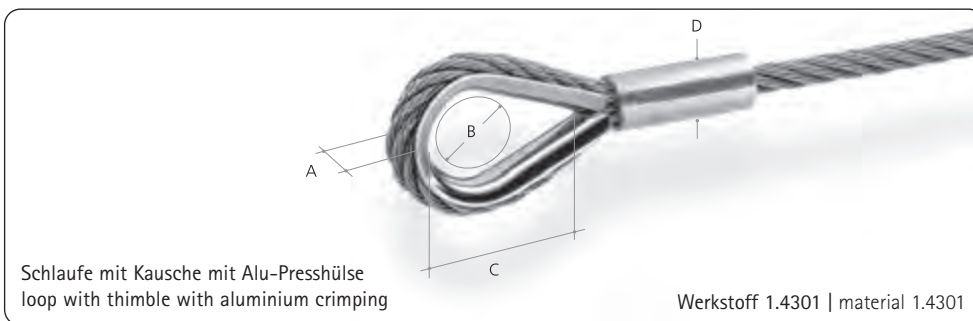

| Art. Nr. item no. | Seil Ø cable Ø | A | B | C | D | |
|----------------------|-------------------|------|----|----|----|---|
| 12 90 00 00 | 4 | 8,0 | 13 | 20 | 8 | 1 |
| 12 90 01 00 | 5 | 9,0 | 16 | 25 | 10 | 1 |
| 12 90 02 00 | 6 | 10,0 | 18 | 28 | 12 | 1 |

■ Schlaufe
Loop

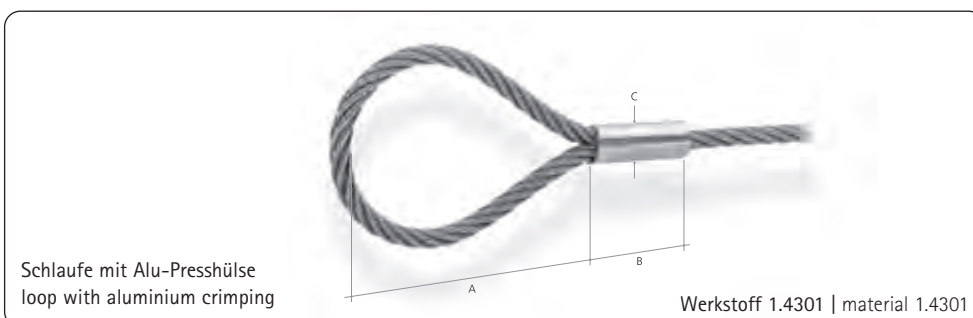

| Art. Nr. item no. | Seil Ø cable Ø | A | B | C | |
|----------------------|-------------------|----|----|----|---|
| 12 10 62 00 | 4 | 60 | 20 | 8 | 1 |
| 12 10 63 00 | 5 | 75 | 25 | 10 | 1 |
| 12 10 64 00 | 6 | 90 | 30 | 12 | 1 |



■ Verpressung, Typ A
swaging, type A

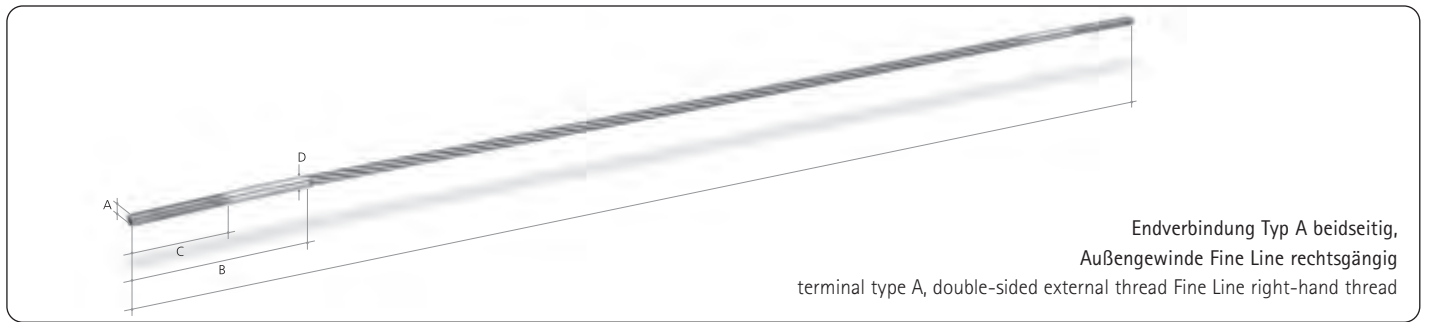

| Art. Nr. item no. | Typ A | Seil Ø cable Ø | A | B | C | D | R/L | |
|----------------------|-------|-------------------|----|-----|----|---|-----|----------|
| 12 10 21 00 | A-43 | 4 | M4 | 60 | 30 | 4 | R | 1+1 lfm. |
| 12 10 22 00 | A-46 | 4 | M4 | 90 | 60 | 4 | R | 1+1 lfm. |
| 12 10 23 00 | A-53 | 5 | M5 | 60 | 30 | 5 | R | 1+1 lfm. |
| 12 10 24 00 | A-56 | 5 | M5 | 90 | 60 | 5 | R | 1+1 lfm. |
| 12 10 25 00 | A-63 | 6 | M6 | 70 | 30 | 6 | R | 1+1 lfm. |
| 12 10 26 00 | A-67 | 6 | M6 | 110 | 70 | 6 | R | 1+1 lfm. |

■ Verpressung, Typ B
swaging, type B

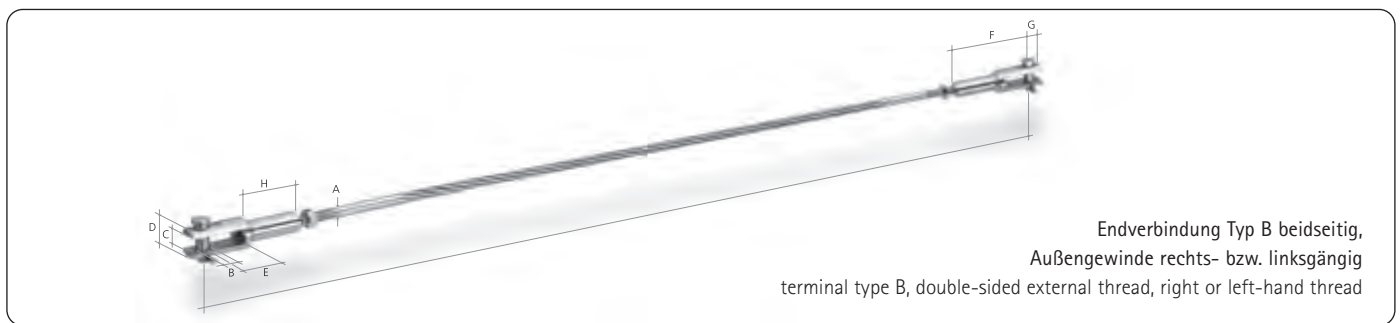

| Art. Nr. item no. | Typ A | Seil Ø cable Ø | A | B | C | D | E | F | G | H | |
|----------------------|-------|-------------------|----|-----|-----|----|------|------|-----|----|----------|
| 12 10 28 00 | B-45 | 4 | M4 | 4,5 | 5,5 | 11 | 13,5 | 40,5 | 5,5 | 27 | 1+1 lfm. |
| 12 10 29 00 | B-53 | 5 | M5 | 6,0 | 6,5 | 14 | 18,0 | 46,0 | 7,0 | 28 | 1+1 lfm. |
| 12 10 30 00 | B-63 | 6 | M6 | 6,0 | 6,5 | 14 | 18,0 | 46,0 | 7,0 | 28 | 1+1 lfm. |





■ Verpressung, Typ D
swaging, type D

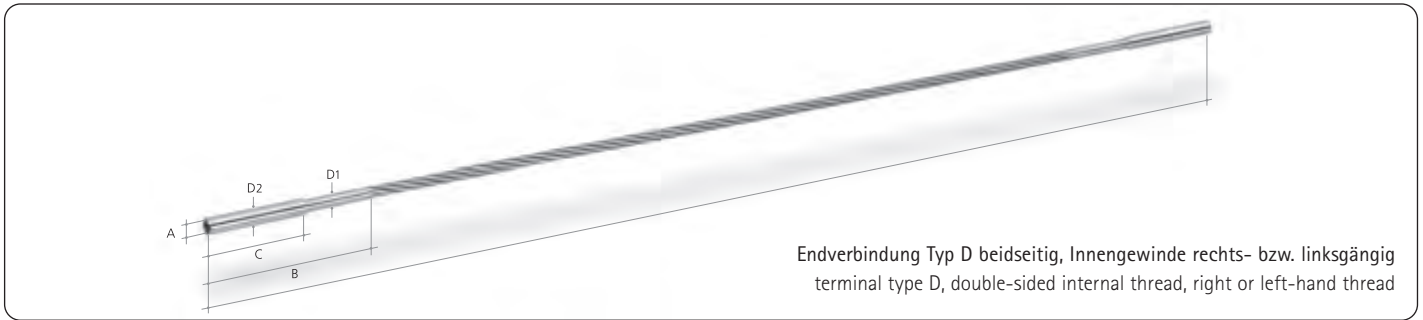

Endverbindung Typ D beidseitig, Innengewinde rechts- bzw. linksgängig
terminal type D, double-sided internal thread, right or left-hand thread

| Art. Nr. item no. | Typ A | Seil Ø cable Ø | A | B | C | D1 | D2 | R/L | |
|----------------------|-------|-------------------|----|----|----|----|----|-----|----------|
| 12 10 34 00 | D-43 | 4 | M4 | 60 | 30 | 4 | 6 | 6 | 1+1 lfm. |
| 12 10 35 00 | D-54 | 5 | M5 | 70 | 35 | 5 | 7 | 7 | 1+1 lfm. |
| 12 10 36 00 | D-65 | 6 | M6 | 85 | 45 | 6 | 8 | 8 | 1+1 lfm. |

■ Verpressung, Typ F
swaging, type F

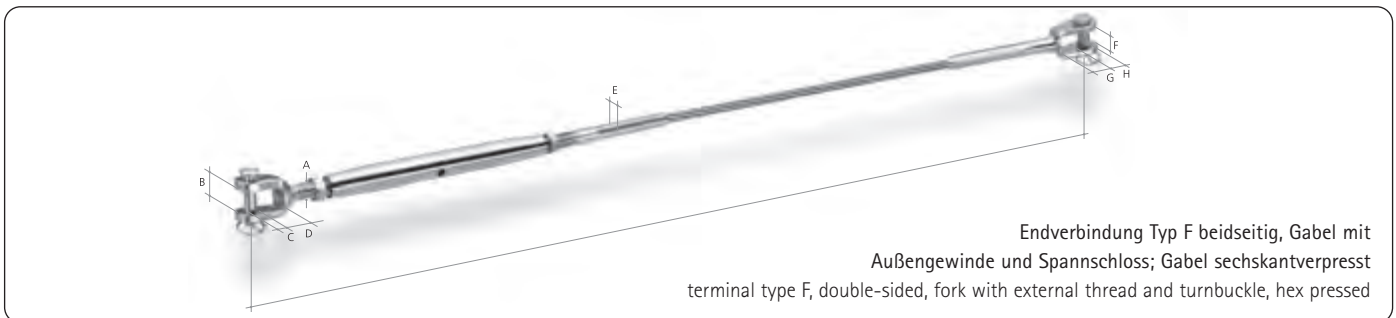

Endverbindung Typ F beidseitig, Gabel mit
Außengewinde und Spannschloss; Gabel sechskantverpresst
terminal type F, double-sided, fork with external thread and turnbuckle, hex pressed

| Art. Nr. item no. | Typ A | Seil Ø cable Ø | A | B | C | D | E | F | G | H | |
|----------------------|-------|-------------------|-----|----|----|----|----|----|----|----|----------|
| 12 10 31 00 | F-45 | 4 | M6 | 8 | 6 | 9 | 7 | 10 | 10 | 6 | 1+1 lfm. |
| 12 10 32 00 | F-56 | 5 | M8 | 10 | 8 | 10 | 8 | 12 | 11 | 9 | 1+1 lfm. |
| 12 10 33 00 | F-67 | 6 | M10 | 12 | 10 | 11 | 10 | 14 | 14 | 10 | 1+1 lfm. |



■ Längendefinitionen
length definitions

■ Außengewinde | external thread



■ Innengewinde | internal thread



■ Außengewinde mit Formanschluss
external thread with positive engagement

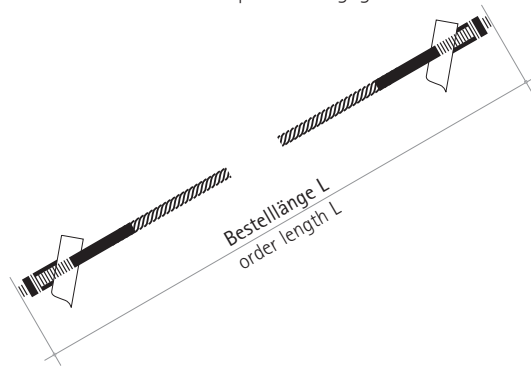

■ Innengewinde mit Formanschluss
internal thread with positive engagement

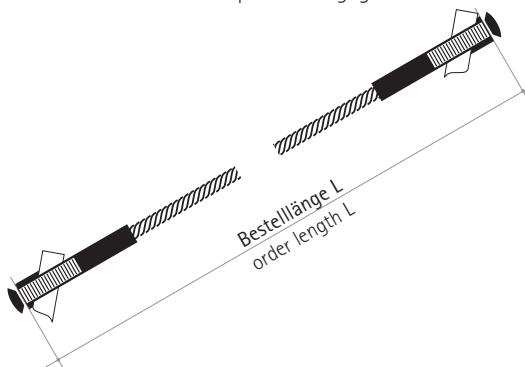

Aussengewinde Fine Line | external thread FINE LINE



Außengewinde sechskantverpresst | external thread, hex pressed

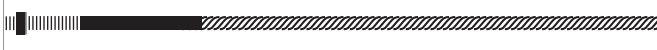

Innengewinde sechskantverpresst | internal thread, hex pressed

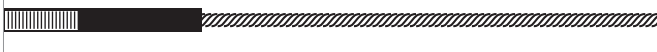

Gabel sechskantverpresst | fork, hex pressed

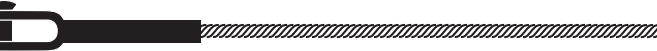

Öse sechskantverpresst | eye, hex pressed

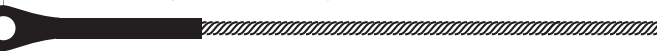

Endhülse | end sleeve

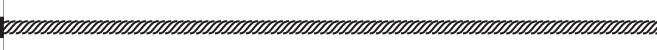

Senkkopf Fine Line rundverpresst | countersink head Fine Line round pressed



Bestelllänge L
order length L

Schleife mit Kausche | loop with thimble



Kugelmutter | ball nut

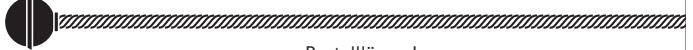

Bestelllänge L
order length L

Öse Fine mit Innengewinde | eye Fine with internal thread



Gabel Fine mit Innengewinde | fork Fine with internal thread



Öse mit Außengewinde | eye Fine with external thread



Gabel mit Außengewinde / Seilspanner | fork with external thread / turnbuckle



Bestelllänge (Spannvorrichtung halb geöffnet)
order length (buckle half open)



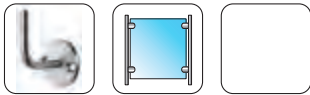

■ Gabel DO IT LINE zur Selbstmontage
fork Do It Line for self-assembly

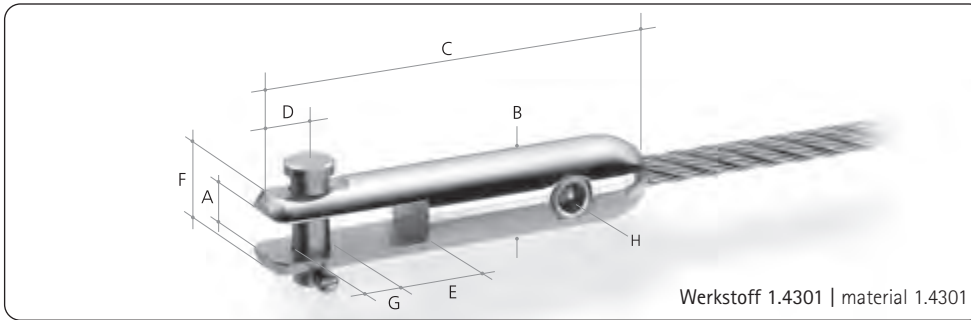

| Art. Nr. item no. | Seil Ø cable Ø | A | B | C | D | E | F | G | H | |
|----------------------|-------------------|-----|----|----|-----|-------|------|-----|----|---|
| 12 20 00 00 | 4 | 5,5 | 13 | 49 | 6,5 | 10,15 | 10,0 | 4,7 | M6 | 1 |
| 12 20 01 00 | 5 | 6,5 | 14 | 65 | 8,0 | 13,90 | 12,6 | 6,2 | M8 | 1 |
| 12 20 02 00 | 6 | 6,5 | 14 | 65 | 8,0 | 13,90 | 12,6 | 6,2 | M8 | 1 |

■ Öse DO IT LINE zur Selbstmontage
eye Do It Line for self-assembly

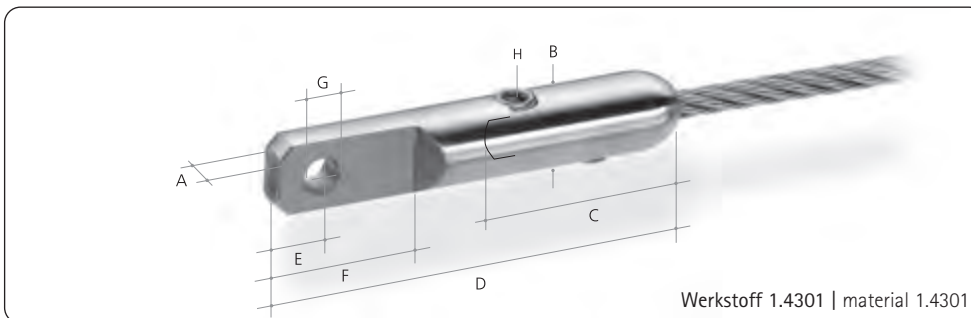

| Art. Nr. item no. | Seil Ø cable Ø | A | B | C | D | E | F | G | H | |
|----------------------|-------------------|-----|----|----|----|-----|----|-----|----|---|
| 12 10 55 00 | 4 | 4,5 | 13 | 27 | 59 | 6,5 | 19 | 4,7 | M6 | 1 |
| 12 10 56 00 | 5 | 6,0 | 14 | 37 | 75 | 8,0 | 25 | 6,2 | M8 | 1 |
| 12 10 57 00 | 6 | 6,0 | 14 | 37 | 75 | 8,0 | 25 | 6,2 | M8 | 1 |

■ Innengewinde, drehbar
internal thread, turnable

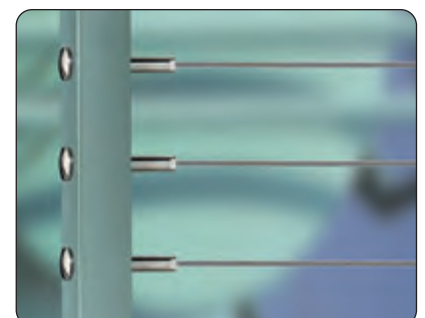
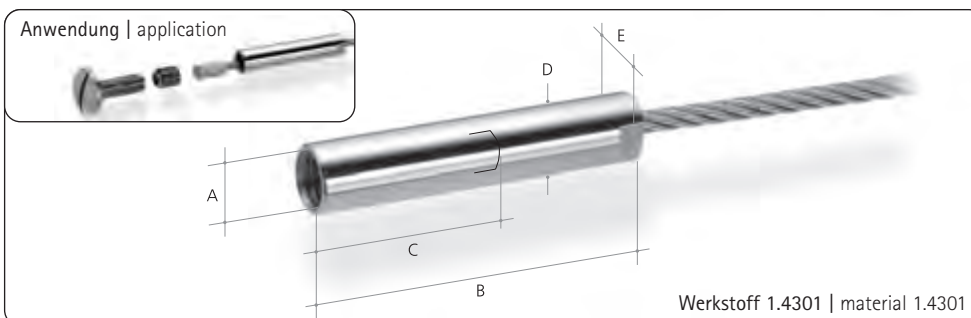

| Art. Nr. item no. | Seil Ø cable Ø | A | B | C | D | E | R/L | |
|----------------------|-------------------|-----|----|----|----|----|-----|---|
| 12 10 59 00 | 4 | M10 | 60 | 30 | 12 | 10 | R | 1 |
| 12 10 60 00 | 5 | M12 | 65 | 30 | 15 | 12 | R | 1 |
| 12 10 61 00 | 6 | M16 | 95 | 50 | 18 | 15 | R | 1 |

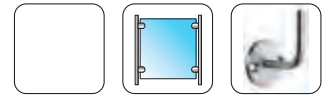

■ Öse Fine mit Innengewinde
eye Fine with internal thread

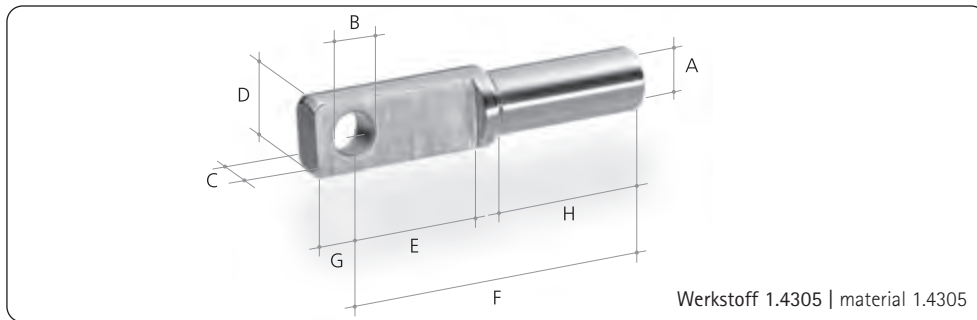

| Art. Nr. item no. | ⊙ A | B | C | D | E | F | G | H | R/L | |
|----------------------|-----|-----|-----|----|------|------|-----|----|-----|---|
| 12 10 49 00 | M4 | 4,7 | 4,5 | 9 | 14,5 | 41,5 | 4,5 | 25 | R | 1 |
| 12 10 50 00 | M5 | 6,2 | 6,0 | 12 | 19,0 | 47,0 | 6,0 | 25 | R | 1 |
| 12 10 51 00 | M6 | 6,2 | 6,0 | 12 | 19,0 | 47,0 | 6,0 | 25 | R | 1 |

■ Außengewinde Do It Line zur Selbstmontage
external thread Do It Line for self-assembly

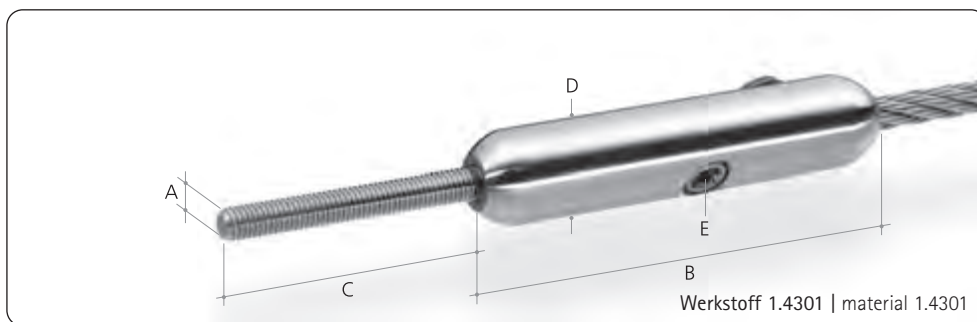

| Art. Nr. item no. | Seil Ø cable Ø | A | B | C | D | E | R/L | |
|----------------------|-------------------|----|----|----|----|----|-----|---|
| 12 10 52 00 | 4 | M4 | 45 | 40 | 13 | M6 | R | 1 |
| 12 10 53 00 | 5 | M5 | 65 | 40 | 14 | M8 | R | 1 |
| 12 10 54 00 | 6 | M6 | 65 | 40 | 14 | M8 | R | 1 |

■ Innengewinde Do It Line zur Selbstmontage
internal thread Do It Line for self-assembly

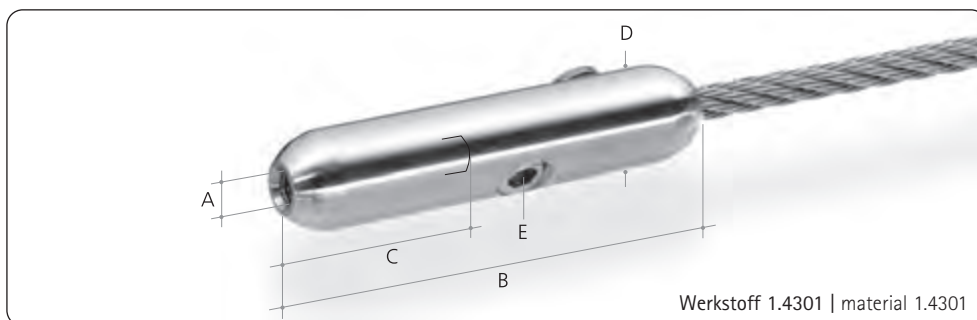

| Art. Nr. item no. | Seil Ø cable Ø | A | B | C | D | E | R/L | |
|----------------------|-------------------|----|----|----|----|----|-----|---|
| 12 20 03 00 | 4 | M4 | 45 | 15 | 13 | M6 | R | 1 |
| 12 20 04 00 | 5 | M5 | 65 | 15 | 14 | M8 | R | 1 |
| 12 20 05 00 | 6 | M6 | 65 | 15 | 14 | M8 | R | 1 |



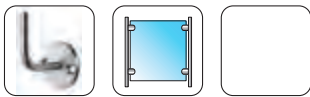

■ Gabel Fine mit Innengewinde
fork Fine with internal thread

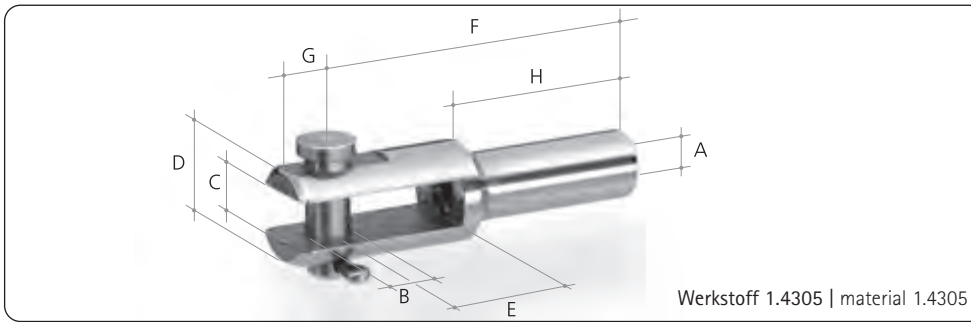

| Art. Nr. item no. | ⊗ A | B | C | D | E | F | G | H | R/L | |
|----------------------|-----|-----|-----|----|------|------|-----|----|-----|---|
| 12 10 43 00 | M4 | 4,5 | 5,5 | 11 | 13,5 | 40,5 | 5,5 | 27 | R | 1 |
| 12 10 44 00 | M5 | 6,0 | 6,5 | 14 | 18,0 | 46,0 | 7,0 | 28 | R | 1 |
| 12 10 45 00 | M6 | 6,5 | 6,5 | 14 | 18,0 | 46,0 | 7,0 | 28 | R | 1 |

■ Gabel Fine mit Außengewinde
fork Fine with external thread

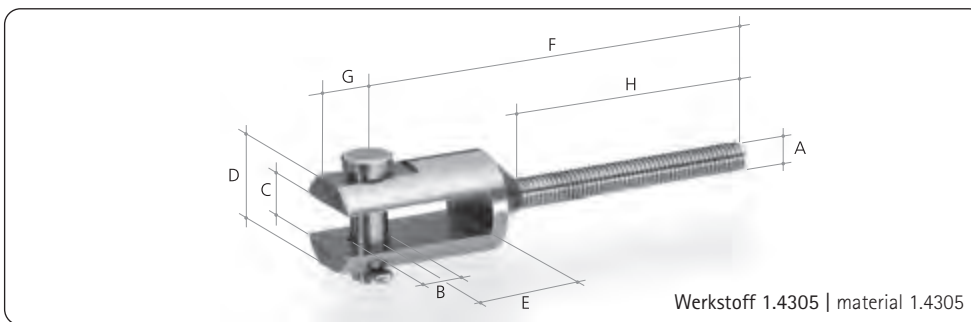

| Art. Nr. item no. | ⊗ A | B | C | D | E | F | G | H | R/L | |
|----------------------|-----|-----|-----|----|------|----|-----|----|-----|---|
| 12 10 46 00 | M4 | 4,5 | 5,5 | 11 | 13,5 | 45 | 5,5 | 30 | R | 1 |
| 12 10 47 00 | M5 | 6,0 | 6,5 | 14 | 18,0 | 67 | 7,0 | 45 | R | 1 |
| 12 10 48 00 | M6 | 6,0 | 6,5 | 14 | 18,0 | 77 | 7,0 | 45 | R | 1 |

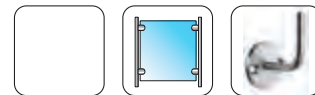

■ Gabel mit Außengewinde
fork with external thread

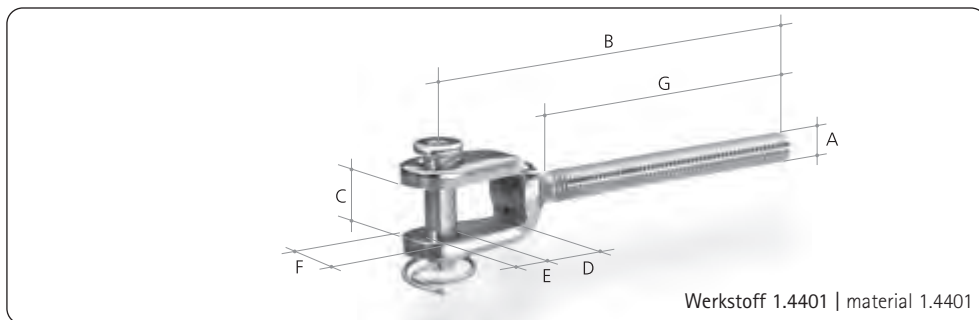

| Art. Nr. item no. | ⊙ A | B | C | D | E | F | G | R/L | |
|----------------------|-----|----|---|---|-----|------|----|-----|---|
| 12 10 65 00 | M4 | 38 | 7 | 9 | 5,0 | 13,0 | 20 | R | 1 |
| 12 10 66 00 | M5 | 60 | 6 | 9 | 5,0 | 13,0 | 41 | R | 1 |
| 12 10 67 00 | M6 | 67 | 8 | 9 | 6,0 | 13,0 | 47 | R | 1 |

■ Öse mit Außengewinde
eye with external thread

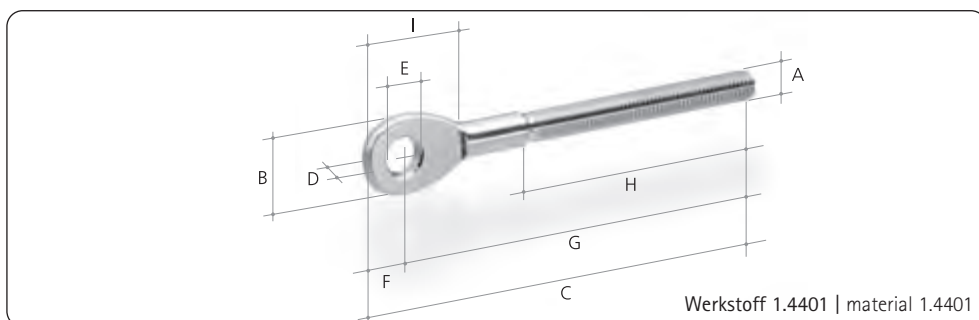

| Art. Nr. item no. | ⊙ A | B | C | D | E | F | G | H | I | R/L | |
|----------------------|-----|----|----|---|-----|-----|----|----|----|-----|---|
| 12 10 68 00 | M5 | 12 | 61 | 3 | 5,5 | 7,0 | 54 | 36 | 18 | R | 1 |
| 12 10 69 00 | M6 | 14 | 69 | 4 | 6,5 | 7,5 | 62 | 38 | 16 | R | 1 |



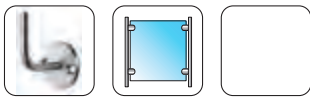

■ Seilspanner mit Gabeln
turnbuckle with forks

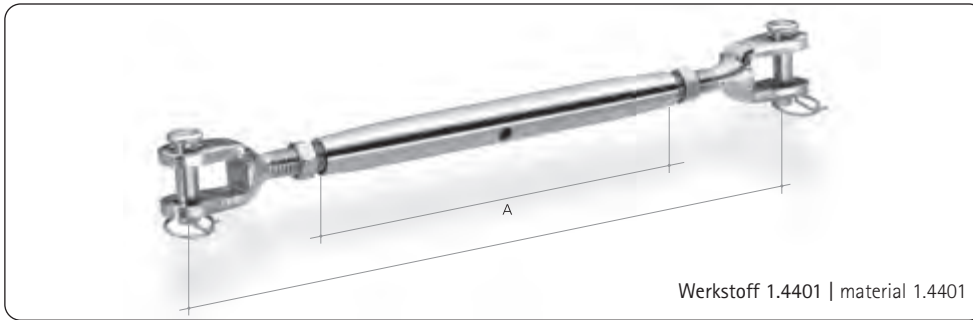

Werkstoff 1.4401 | material 1.4401

| Art. Nr. item no. | ⊙ | A | B | |
|----------------------|----|----|-----|---|
| 12 10 72 00 | M4 | 80 | 125 | 1 |
| 12 10 73 00 | M5 | 80 | 130 | 1 |
| 12 10 74 00 | M6 | 90 | 140 | 1 |

■ Seilspanner
turnbuckle

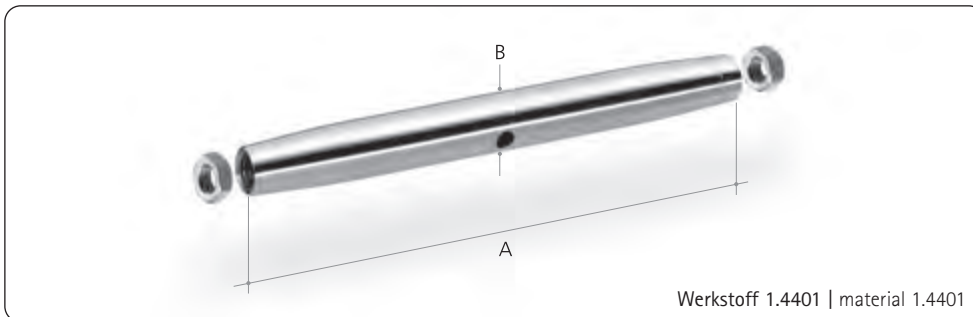

Werkstoff 1.4401 | material 1.4401

| Art. Nr. item no. | ⊙ | A | B | |
|----------------------|----|----|----|---|
| 12 10 75 00 | M4 | 80 | 7 | 1 |
| 12 10 76 00 | M5 | 80 | 8 | 1 |
| 12 10 77 00 | M6 | 90 | 10 | 1 |





■ Querseilhalter
cross cable holder

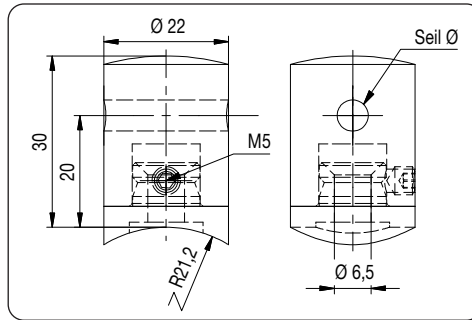

| Art. Nr. item no. | Seil Ø cable Ø | für Rohr for tube | |
|----------------------|-------------------|----------------------|---|
| 10 40 12 00 | 4 | Ø 42,4 | 4 |
| 10 40 13 00 | 5 | Ø 42,4 | 4 |
| 10 40 14 00 | 6 | Ø 42,4 | 4 |

■ Querseilhalter
cross cable holder

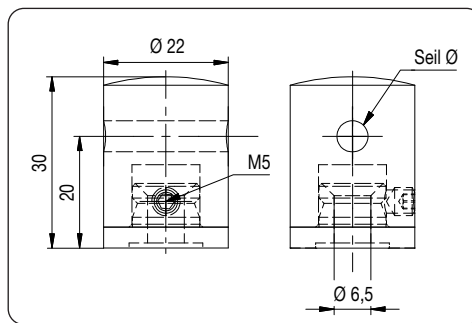

| Art. Nr. item no. | Seil Ø cable Ø | für Rohr for tube | |
|----------------------|-------------------|--------------------------|---|
| 10 40 15 00 | 4 | <input type="checkbox"/> | 4 |
| 10 40 16 00 | 5 | <input type="checkbox"/> | 4 |
| 10 40 17 00 | 6 | <input type="checkbox"/> | 4 |





■ Ringschraube
ring bolt

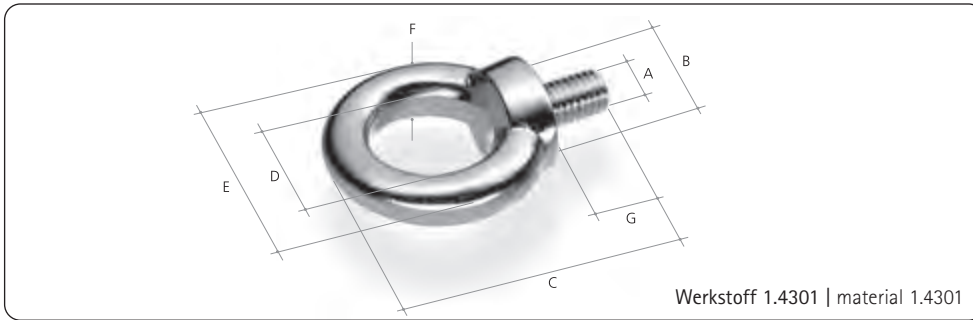

| Art. Nr. item no. | ⊗ A | B | C | D | E | F | G | |
|----------------------|-----|----|----|----|----|----|------|---|
| 12 10 78 00 | M8 | 20 | 49 | 20 | 36 | 8 | 13,0 | 1 |
| 12 10 79 00 | M10 | 25 | 62 | 25 | 45 | 10 | 17,0 | 1 |
| 12 10 80 00 | M12 | 30 | 73 | 30 | 54 | 12 | 20,5 | 1 |

■ Ringmutter
ring nut

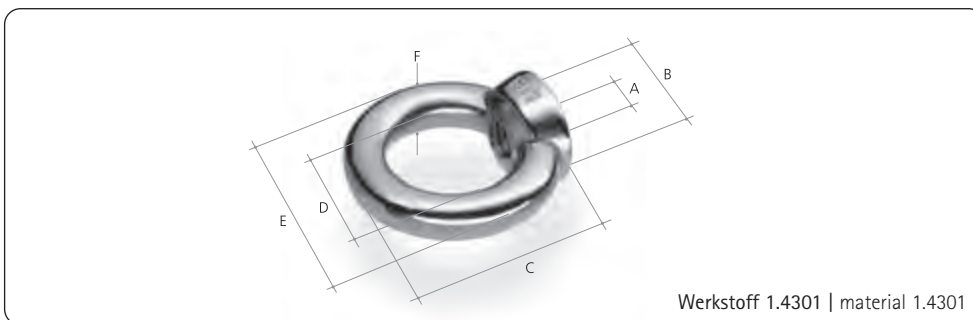

| Art. Nr. item no. | ⊗ A | B | C | D | E | F | |
|----------------------|-----|----|----|----|----|----|---|
| 12 10 81 00 | M8 | 20 | 36 | 20 | 36 | 8 | 1 |
| 12 10 82 00 | M10 | 25 | 45 | 25 | 45 | 10 | 1 |
| 12 10 83 00 | M12 | 30 | 53 | 30 | 54 | 12 | 1 |



■ Schäkel
shackle

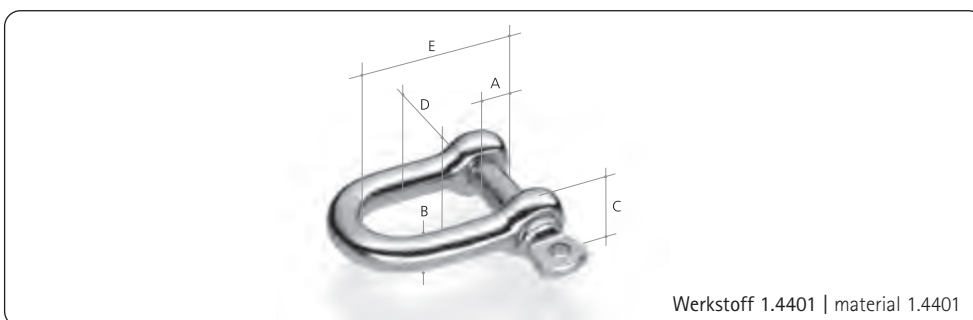

| Art. Nr. item no. | A | B | C | D | E | |
|----------------------|----|----|----|----|----|---|
| 12 10 84 00 | 5 | 5 | 10 | 10 | 17 | 1 |
| 12 10 85 00 | 6 | 6 | 12 | 12 | 21 | 1 |
| 12 10 86 00 | 8 | 8 | 16 | 16 | 28 | 1 |
| 12 10 87 00 | 10 | 10 | 19 | 19 | 35 | 1 |

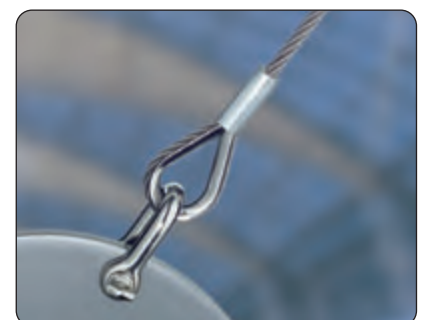

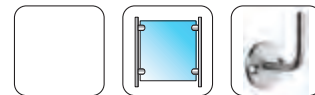

■ Duplex-Klemme
duplex clamp

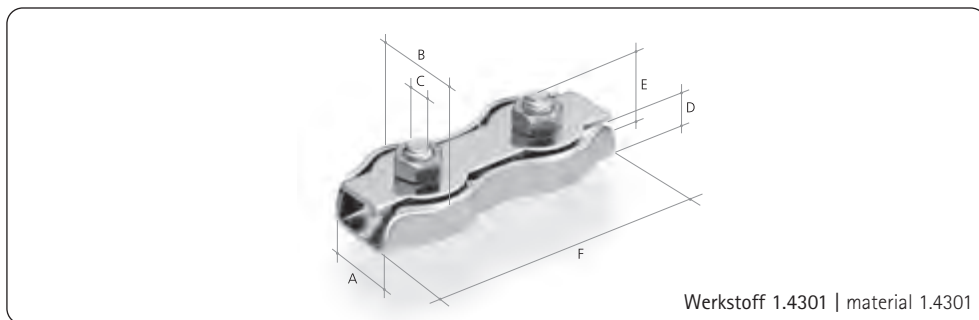

Werkstoff 1.4301 | material 1.4301



| Art. Nr. item no. | Seil Ø cable Ø | A | B | C | D | E | F | |
|----------------------|-------------------|----|----|----|---|----|----|---|
| 12 10 88 00 | 4 | 8 | 12 | M4 | 5 | 14 | 30 | 1 |
| 12 10 89 00 | 5 | 10 | 20 | M5 | 8 | 18 | 50 | 1 |
| 12 10 90 00 | 6 | 12 | 24 | M6 | 9 | 23 | 60 | 1 |

■ Simplex-Klemme
simplex clamp

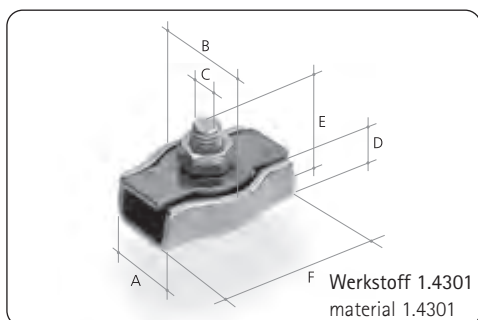

Werkstoff 1.4301
material 1.4301

| Art. Nr. item no. | Seil Ø cable Ø | A | B | C | D | E | F | |
|----------------------|-------------------|----|----|----|---|----|----|---|
| 12 10 91 00 | 4 | 8 | 18 | M5 | 7 | 18 | 20 | 1 |
| 12 10 92 00 | 5 | 10 | 20 | M5 | 8 | 18 | 25 | 1 |
| 12 10 93 00 | 6 | 12 | 24 | M6 | 9 | 23 | 30 | 1 |

■ Formschluss für flache Profile
positive engagement for flat profiles

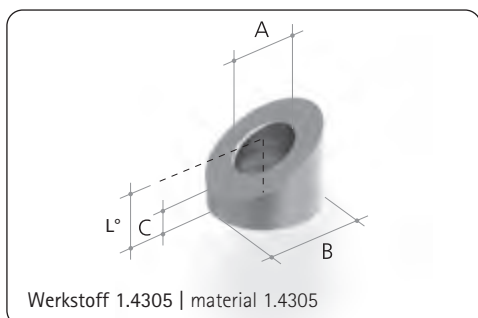

Werkstoff 1.4305 | material 1.4305

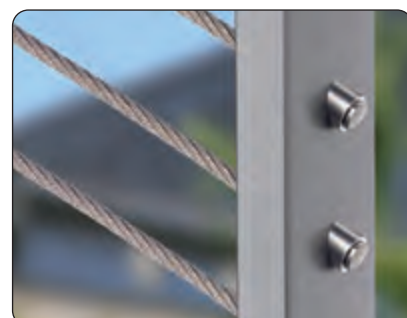
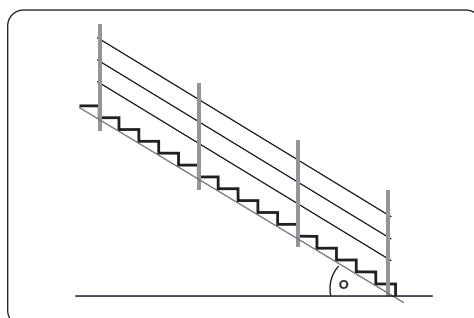

| Art. Nr. item no. | ⊙ | A | B | C | L in mm bei Steigungswinkel lead angle | | | | | | | | | | |
|----------------------|----|-----|----|---|--|-----|-----|-----|-----|-----|-----|------|------|---|--|
| | | | | | 0° | 20° | 25° | 30° | 35° | 40° | 45° | 50° | 55° | | |
| 12 90 03 00 | M4 | 4,5 | 10 | 3 | 10 | 4,8 | 5,3 | 5,9 | 6,5 | 7,2 | 8,0 | 9,0 | 10,1 | 1 | |
| 12 90 04 00 | M5 | 5,5 | 10 | 3 | 10 | 4,8 | 5,3 | 5,9 | 6,5 | 7,2 | 8,0 | 9,0 | 10,1 | 1 | |
| 12 90 05 00 | M6 | 6,5 | 13 | 3 | 10 | 5,4 | 6,0 | 6,8 | 7,8 | 8,5 | 9,5 | 10,7 | 12,3 | 1 | |

INFO
Bei Bestellung bitte Steigungswinkel angeben! | When ordering, please specify gradient angle!



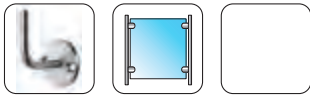

■ Formanschluss für runde Profile
positive engagement for round profiles

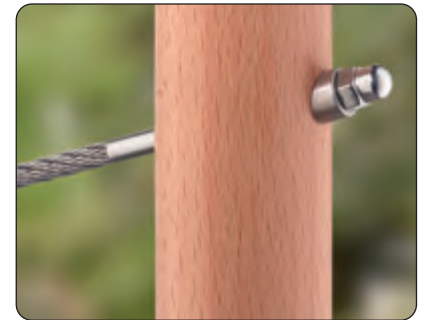
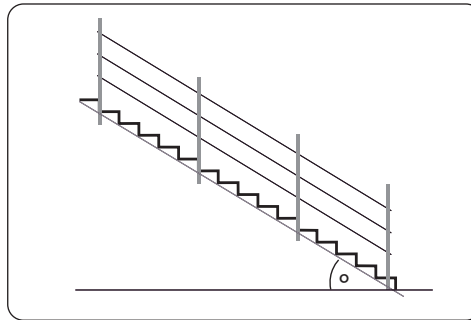
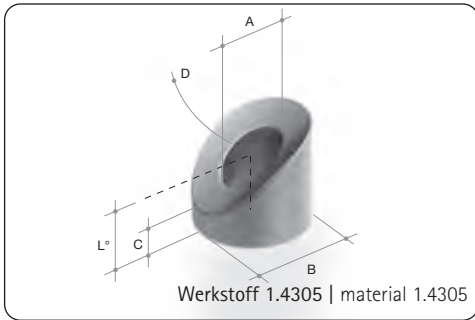

INFO

Bei Bestellung bitte Steigungswinkel angeben! | When ordering, please specify gradient angle!

| Art. Nr. item no. | ⊗ | A | B | C | D | 0° | L in mm bei Steigungswinkel lead angle | | | | | | | | |
|----------------------|----|-----|----|---|------|----|--|-----|-----|-----|-----|-----|------|------|---|
| | | | | | | | 20° | 25° | 30° | 35° | 40° | 45° | 50° | 55° | |
| 12 90 06 00 | M4 | 4,5 | 10 | 3 | 42,4 | 10 | 4,8 | 5,3 | 5,9 | 6,5 | 7,2 | 8,0 | 9,0 | 10,1 | 1 |
| 12 90 07 00 | M5 | 5,5 | 10 | 3 | 42,4 | 10 | 4,8 | 5,3 | 5,9 | 6,5 | 7,2 | 8,0 | 9,0 | 10,1 | 1 |
| 12 90 08 00 | M6 | 6,5 | 13 | 3 | 42,4 | 10 | 5,4 | 6,0 | 6,8 | 7,8 | 8,5 | 9,5 | 10,7 | 12,3 | 1 |

■ Gewindestift
set screw



| Art. Nr. item no. | ⊗ | L | R/L | |
|----------------------|----|----|-----|----|
| 12 10 94 00 | M4 | 30 | R | 10 |
| 12 10 95 00 | M5 | 40 | R | 10 |
| 12 10 96 00 | M6 | 40 | R | 10 |

■ Klemmring
clamp ring

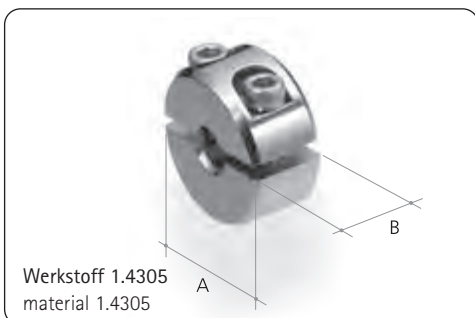

| Art. Nr. | Seil Ø cable Ø | A | B | |
|-------------|-------------------|----|----|---|
| 12 20 06 00 | 4 | 15 | 10 | 1 |
| 12 20 07 00 | 5 | 20 | 10 | 1 |
| 12 20 08 00 | 6 | 20 | 10 | 1 |

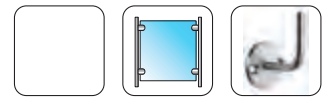

■ **Stockschraube**
hanger bolt

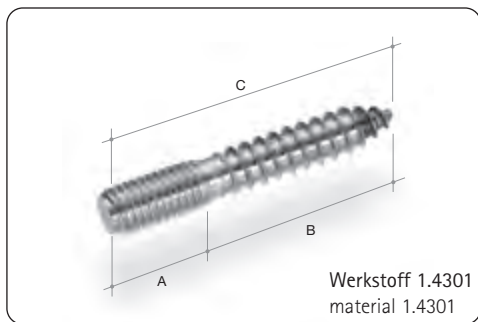

| Art. Nr. item no. | ⊙ | A | B | C | R/L | |
|----------------------|----|----|----|-----|-----|----|
| 12 10 97 00 | M5 | 20 | 30 | 50 | R | 10 |
| 12 10 98 00 | M6 | 30 | 44 | 74 | R | 10 |
| 12 11 26 00 | M8 | 40 | 60 | 100 | R | 10 |

■ **Becherschraube**
pan-head screw

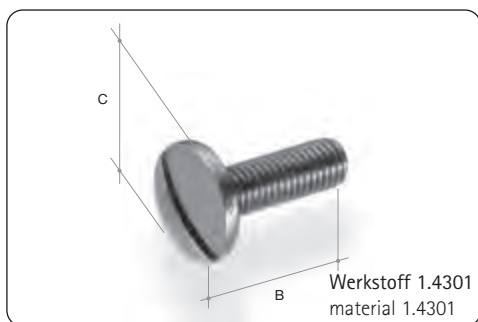

| Art. Nr. item no. | ⊙ | B | C | |
|----------------------|----|----|------|----|
| 12 10 99 00 | M4 | 25 | 10,0 | 10 |
| 12 20 09 00 | M5 | 30 | 12,5 | 10 |
| 12 20 10 00 | M6 | 30 | 14,0 | 10 |
| 12 11 00 00 | M8 | 30 | 17,0 | 10 |

■ **Hülsenmutter**
sleeve nut

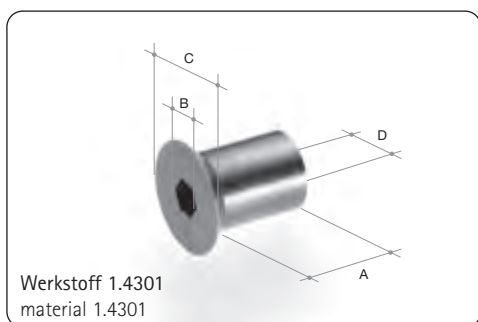

| Art. Nr. item no. | ⊙ | A | B | C | D | |
|----------------------|----|----|---|----|-----|----|
| 12 20 11 00 | M5 | 15 | 3 | 10 | 6,6 | 10 |
| 12 20 12 00 | M6 | 16 | 4 | 12 | 8,0 | 10 |
| 12 11 01 00 | M8 | 16 | 5 | 16 | 11 | 10 |





Sechskantmutter | hex nut

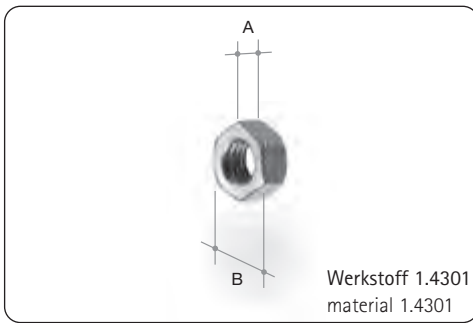

| Art. Nr. item no. | ⊗ | A | B | R/L | |
|----------------------|----|-----|------|-----|----|
| 12 20 13 00 | M4 | 3,2 | 7,0 | R | 10 |
| 12 20 14 00 | M5 | 4,0 | 8,0 | R | 10 |
| 12 20 15 00 | M6 | 5,0 | 10,0 | R | 10 |
| 12 11 02 00 | M8 | 6,5 | 13,0 | R | 10 |

Unterlegscheibe | washer

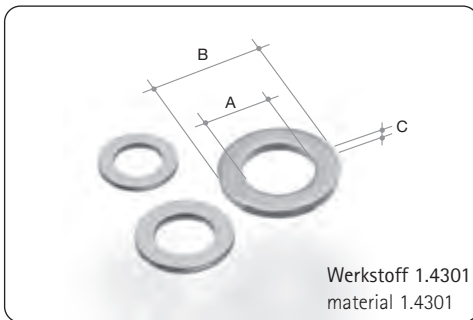

| Art. Nr. item no. | A | B | C | |
|----------------------|-----|----|-----|----|
| 12 20 16 00 | 4,3 | 8 | 0,5 | 10 |
| 12 20 17 00 | 5,3 | 9 | 1,0 | 10 |
| 12 20 18 00 | 6,4 | 11 | 1,6 | 10 |
| 12 11 03 00 | 8,4 | 15 | 1,6 | 10 |

Hutmutter | cap nut

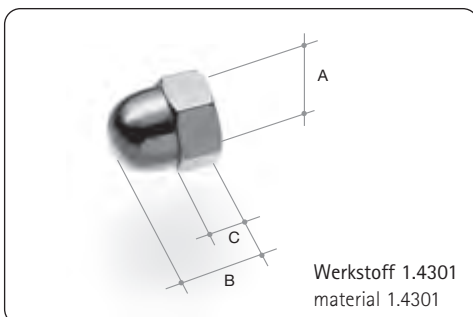

| Art. Nr. item no. | ⊗ | A | B | C | |
|----------------------|-----|----|------|------|----|
| 12 20 19 00 | M4 | 8 | 7,0 | 4,1 | 10 |
| 12 20 20 00 | M5 | 10 | 8,0 | 5,9 | 10 |
| 12 20 21 00 | M6 | 12 | 10,0 | 6,0 | 10 |
| 12 11 04 00 | M8 | 15 | 13,0 | 8,5 | 10 |
| 12 11 27 00 | M10 | 18 | 17,0 | 10,0 | 10 |



■ Inhalt | content

- Designstäbe „KARO“ | design bar infills "KARO" 186
- Designstäbe „RONDO“ | design bar infills "RONDO" 188
- Designstäbe „PLATTO“ | design bar infills "PLATTO" 189
- Designstäbe „BELLO“ | design bar infills "BELLO" 190
- Designstäbe „TRIO“ | design bar infills "TRIO" 191



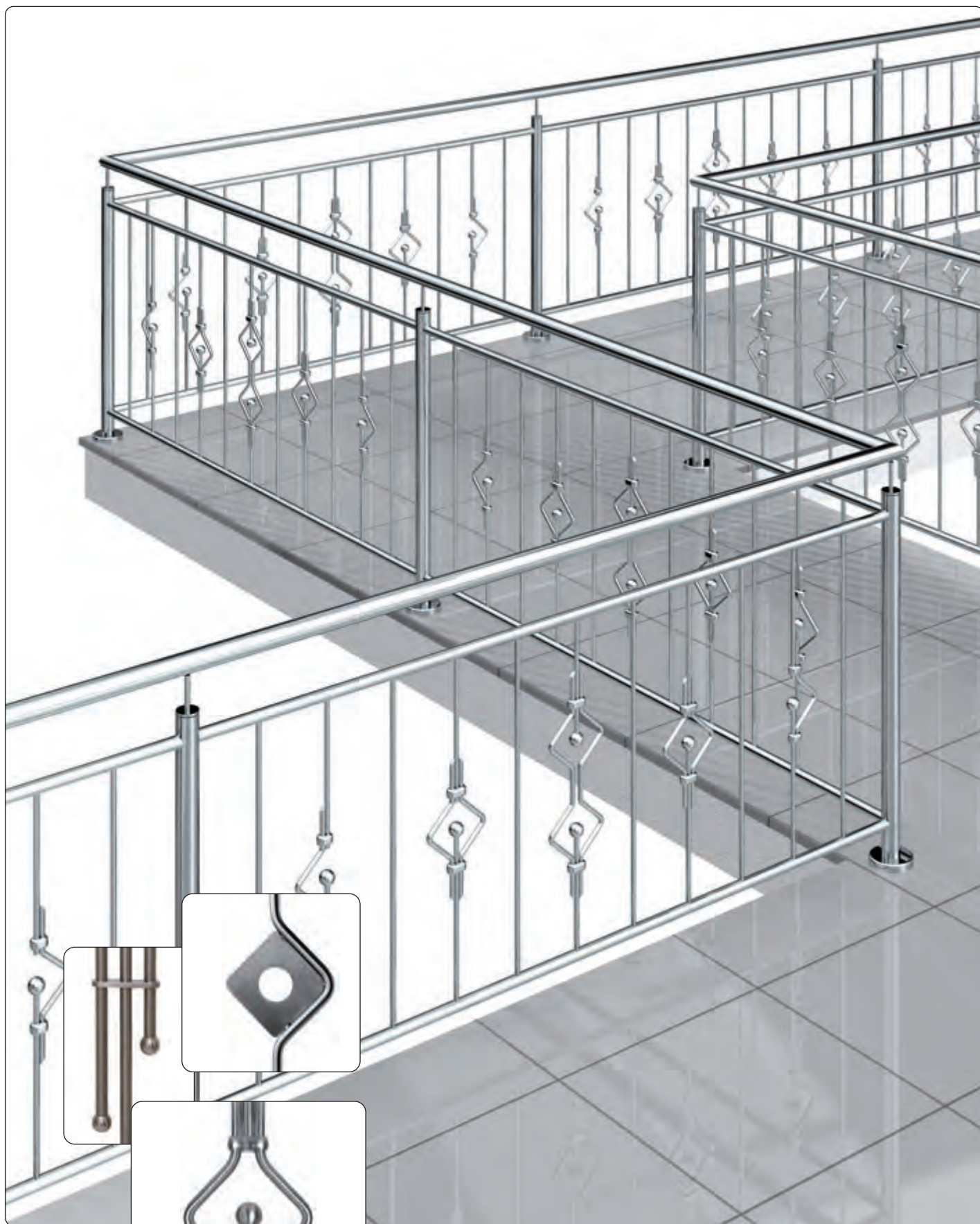

■ Designstäbe
design bar infills

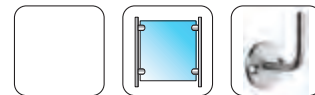

■ Designstäbe „KARO“ | design bar infills "KARO"

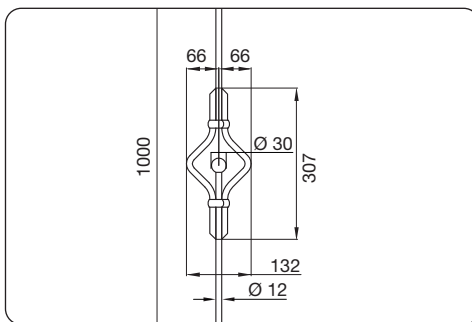
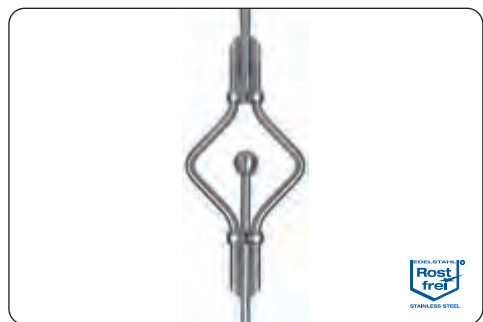

| Art. Nr. item no. | Material material | Kugel ball | Bund ring | Länge length | |
|----------------------|----------------------|---------------|--------------|-----------------|---|
| 10 70 04 00 | V2A (1.4301) | MS | MS | 1000 | 1 |
| 10 70 05 00 | V2A (1.4301) | VA | VA | 1000 | 1 |

■ Designstäbe „KARO“ | design bar infills "KARO"

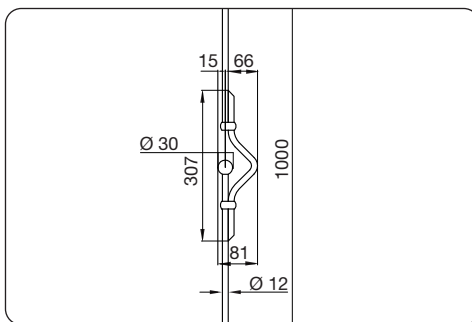

| Art. Nr. item no. | Material material | Kugel ball | Bund ring | Länge length | |
|----------------------|----------------------|---------------|--------------|-----------------|---|
| 10 70 06 00 | V2A (1.4301) | MS | MS | 1000 | 1 |
| 10 70 07 00 | V2A (1.4301) | VA | VA | 1000 | 1 |





■ Designstäbe „KARO“ | design bar infills "KARO"

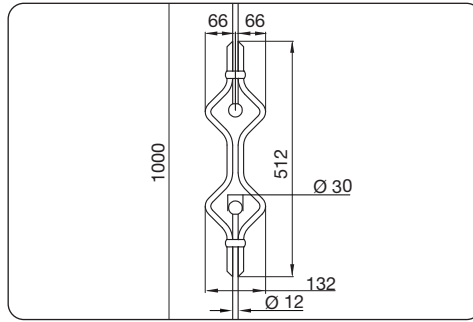
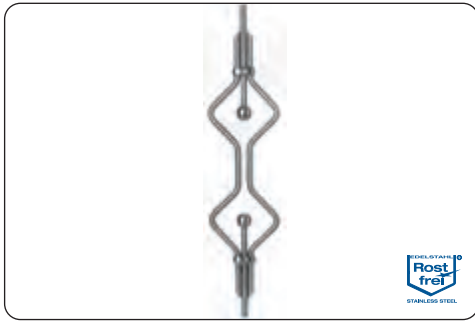

| Art. Nr. item no. | Material material | Kugel ball | Bund ring | Länge length | |
|----------------------|----------------------|---------------|--------------|-----------------|---|
| 10 70 08 00 | V2A (1.4301) | MS | MS | 1000 | 1 |
| 10 70 09 00 | V2A (1.4301) | VA | VA | 1000 | 1 |

■ Designstäbe „KARO“ | design bar infills "KARO"

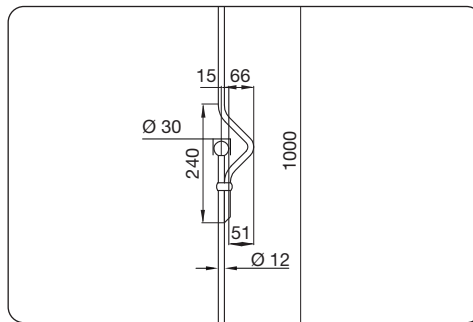
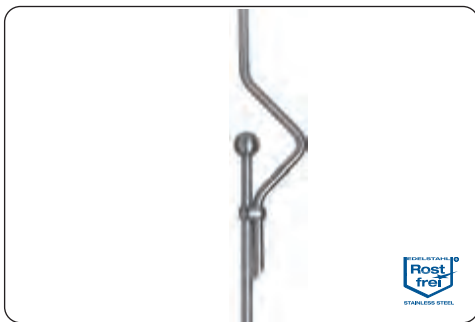

| Art. Nr. item no. | Material material | Kugel ball | Bund ring | Länge length | |
|----------------------|----------------------|---------------|--------------|-----------------|---|
| 10 70 12 00 | V2A (1.4301) | MS | MS | 1000 | 1 |
| 10 70 13 00 | V2A (1.4301) | VA | VA | 1000 | 1 |



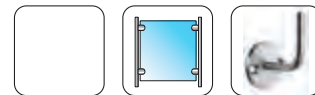

■ Designstäbe „RONDO“ | design bar infills „RONDO“

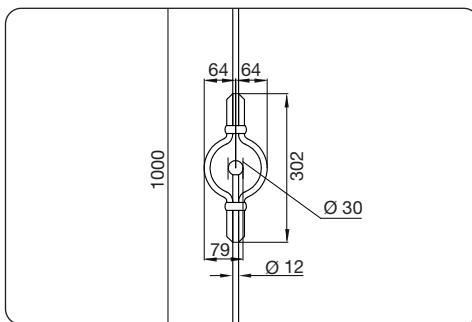

| Art. Nr. item no. | Material material | Kugel ball | Bund ring | Länge length | |
|----------------------|----------------------|---------------|--------------|-----------------|---|
| 10 70 00 00 | V2A (1.4301) | MS | MS | 1000 | 1 |
| 10 70 01 00 | V2A (1.4301) | VA | VA | 1000 | 1 |

■ Designstäbe „RONDO“ | design bar infills „RONDO“

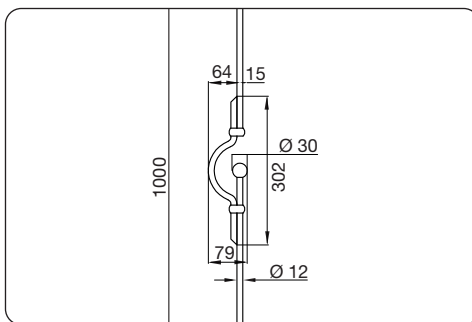

| Art. Nr. item no. | Material material | Kugel ball | Bund ring | Länge length | |
|----------------------|----------------------|---------------|--------------|-----------------|---|
| 10 70 02 00 | V2A (1.4301) | MS | MS | 1000 | 1 |
| 10 70 03 00 | V2A (1.4301) | VA | VA | 1000 | 1 |





■ Designstäbe „PLATTO“ | design bar infills "PLATTO"

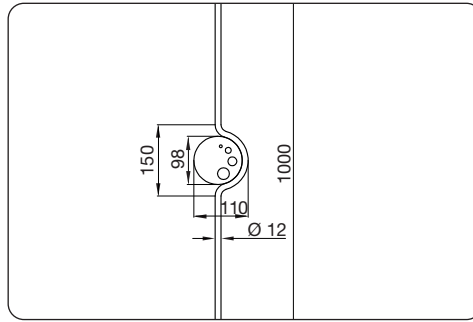

| Art. Nr. item no. | Material material | Länge length | |
|----------------------|----------------------|-----------------|---|
| 10 70 15 00 | V2A (1.4301) | 1000 | 1 |

■ Designstäbe „PLATTO“ | design bar infills "PLATTO"

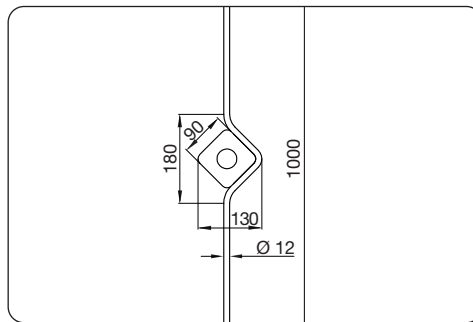

| Art. Nr. item no. | Material material | Länge length | |
|----------------------|----------------------|-----------------|---|
| 10 70 16 00 | V2A (1.4301) | 1000 | 1 |



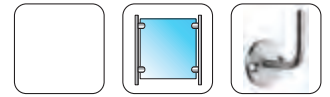

■ Designstäbe „BELLO“ | design bar infills „BELLO“

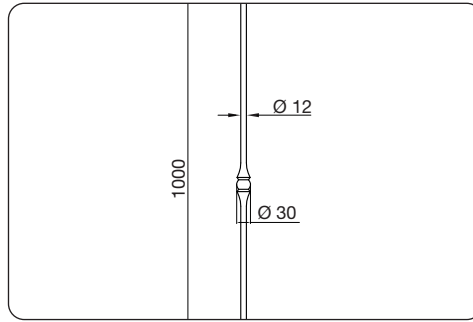

| Art. Nr. item no. | Material material | Kugel ball | Länge length | |
|----------------------|----------------------|---------------|-----------------|---|
| 10 70 10 00 | V2A (1.4301) | VA | 1000 | 1 |
| 10 70 11 00 | V2A (1.4301) | MS | 1000 | 1 |

■ Designstäbe „BELLO“ | design bar infills „BELLO“

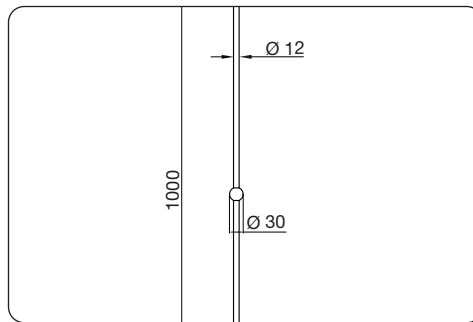

| Art. Nr. item no. | Material material | Kugel ball | Länge length | |
|----------------------|----------------------|---------------|-----------------|---|
| 10 70 14 00 | V2A (1.4301) | VA | 1000 | 1 |

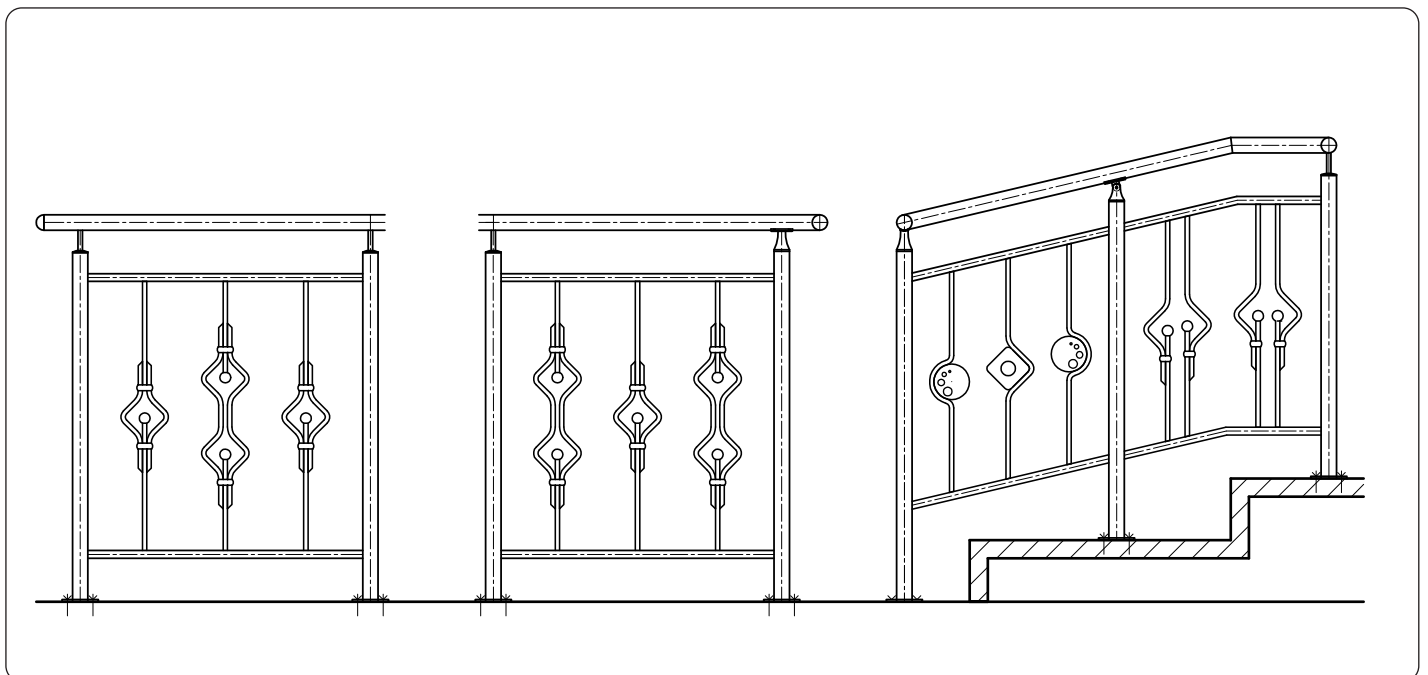



■ Designstäbe „TRIO“ | design bar infills "TRIO"

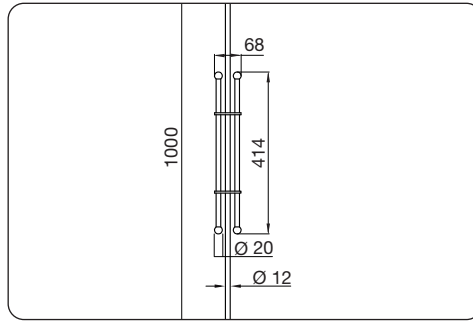

| Art. Nr. item no. | Material material | Kugel ball | Länge length | |
|----------------------|----------------------|---------------|-----------------|---|
| 10 70 17 00 | V2A (1.4301) | VA | 1000 | 1 |

■ Designstäbe „TRIO“ | design bar infills "TRIO"

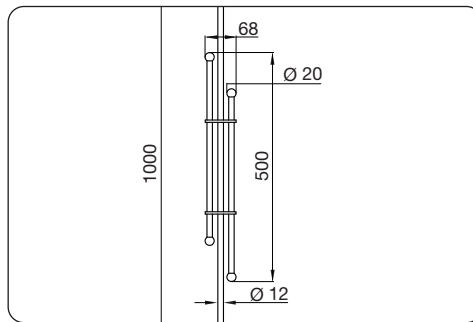

| Art. Nr. item no. | Material material | Kugel ball | Länge length | |
|----------------------|----------------------|---------------|-----------------|---|
| 10 70 18 00 | V2A (1.4301) | VA | 1000 | 1 |

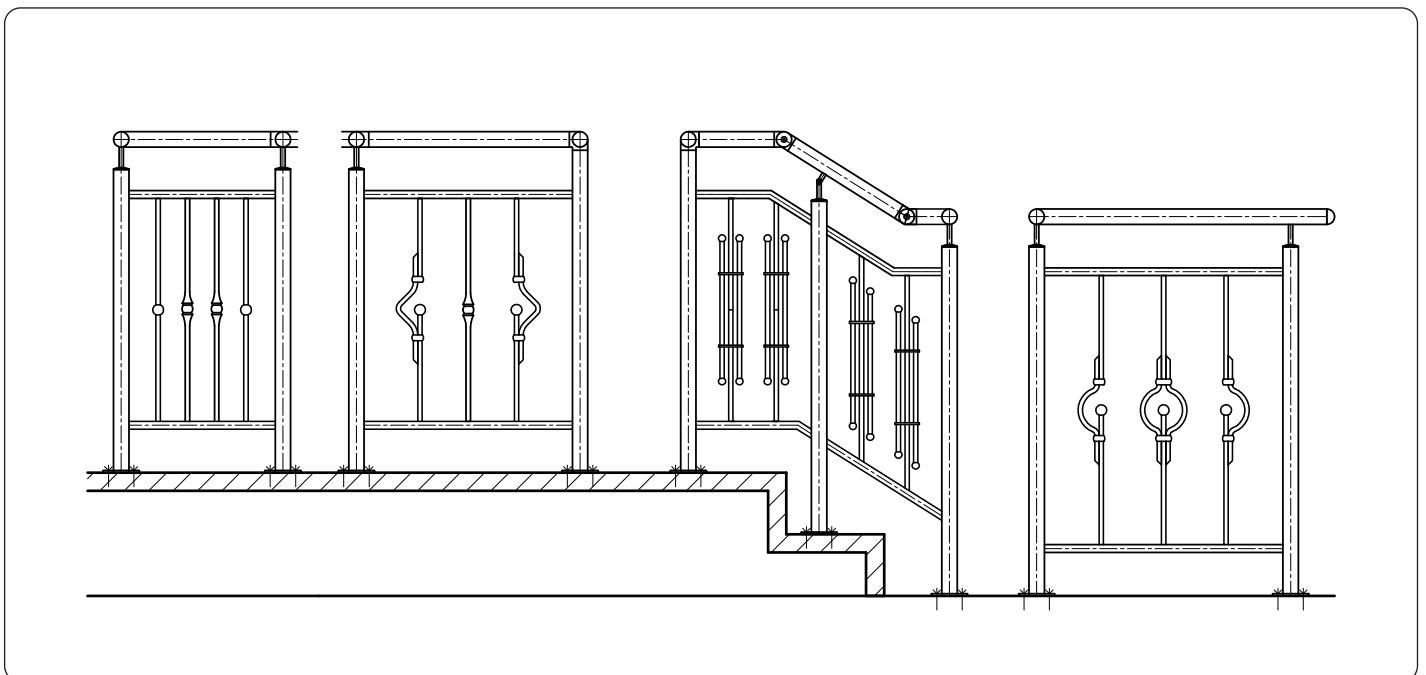

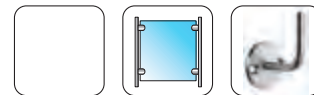

■ Inhalt | content

- Handlauf Biegearbeiten | handrail bending work 194
- Geländer/Rahmen Biegearbeiten 196
bending work / banisters & frames
- Wendeltreppen Biegearbeiten | spiral stair bending work 199

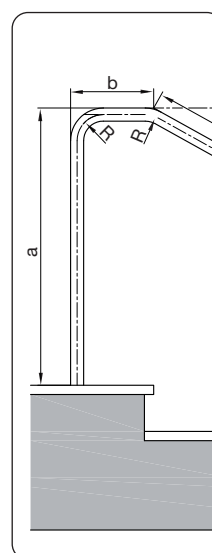
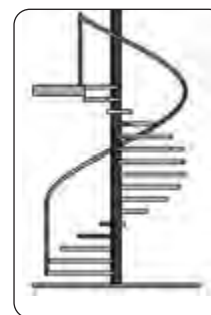
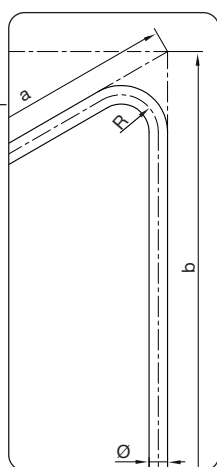

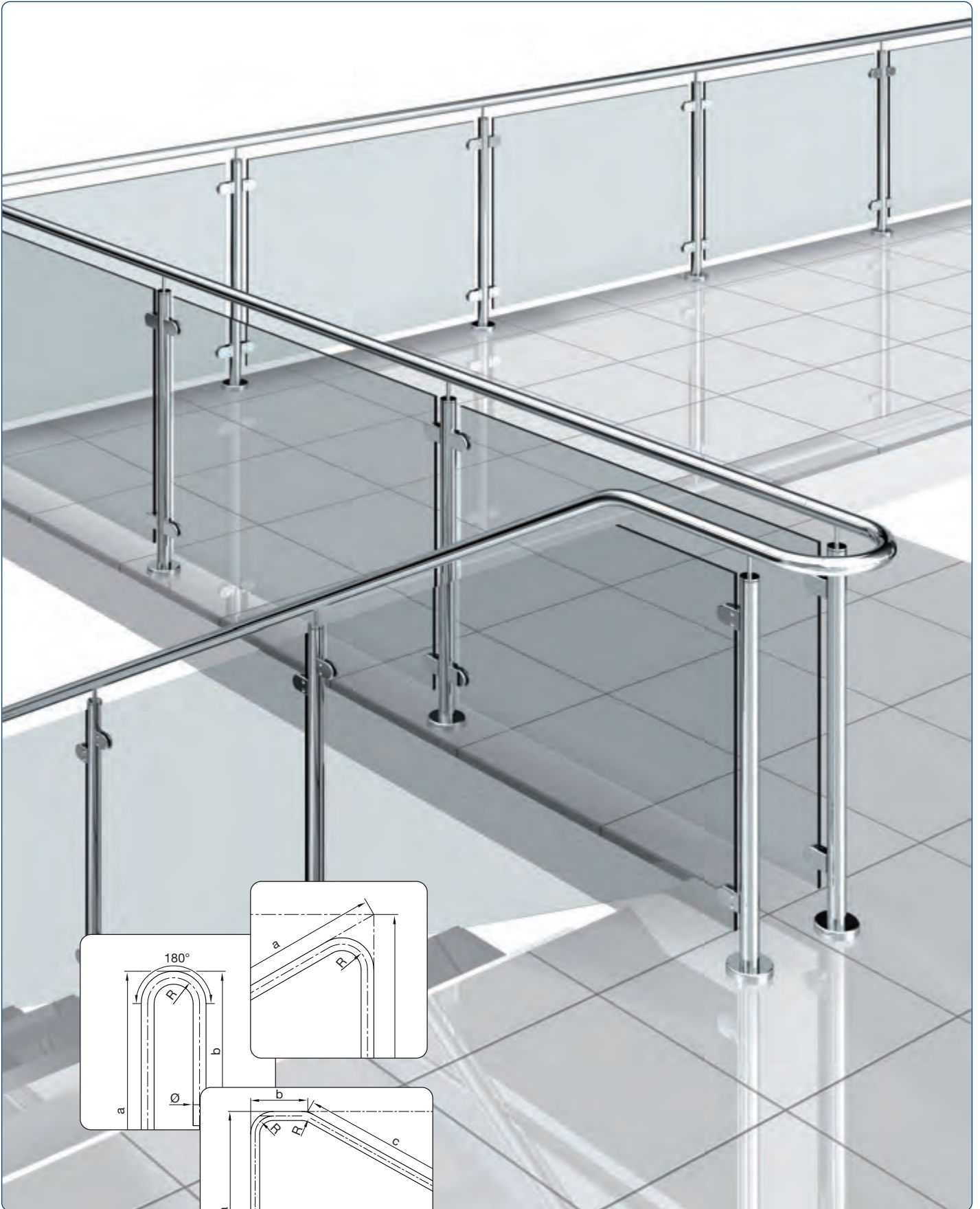

■ Biegearbeiten / Geländer & Rahmen
bending work / banisters & frames





Handlauf Biegearbeiten | handrail bending work

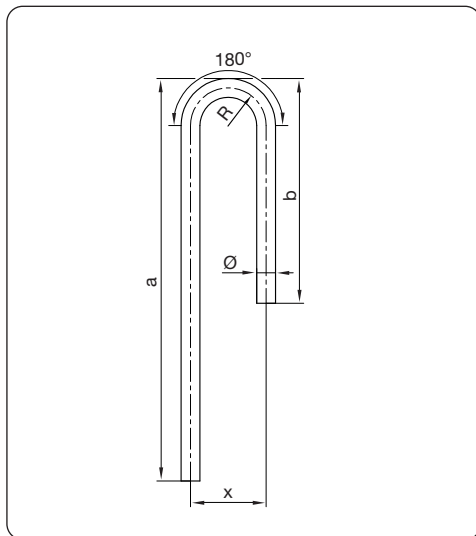

| Ausführung design | Ø | R | X | 304 (V2A) | 316 (V4A) | Stückzahl units |
|-------------------|------------|-----|-----|--------------------------|--------------------------|-----------------|
| | 33,7 x 2,0 | 67 | 134 | <input type="checkbox"/> | <input type="checkbox"/> | |
| a _____ | 42,4 x 2,0 | 85 | 170 | <input type="checkbox"/> | <input type="checkbox"/> | |
| b _____ | 48,3 x 2,0 | 97 | 194 | <input type="checkbox"/> | <input type="checkbox"/> | |
| | 60,3 x 2,0 | 121 | 242 | <input type="checkbox"/> | <input type="checkbox"/> | |

- ungeschliffen, d. h. Rohr wird nach der Bearbeitung nicht nachgeschliffen
unground, i.e. tube is not reworked after processing
- Rohr nach dem Biegen nachschleifen, Korn 240
regrind after bending, 240 grit

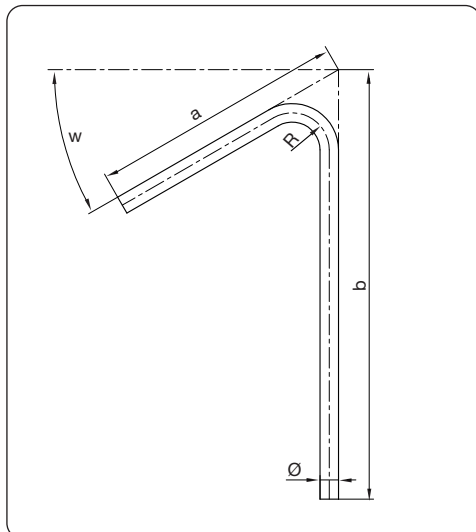

| Ausführung design | Ø | R | 304 (V2A) | 316 (V4A) | Stückzahl units |
|-------------------|------------|-----|--------------------------|--------------------------|-----------------|
| W _____ ° | 33,7 x 2,0 | 67 | <input type="checkbox"/> | <input type="checkbox"/> | |
| a _____ | 42,4 x 2,0 | 85 | <input type="checkbox"/> | <input type="checkbox"/> | |
| b _____ | 48,3 x 2,0 | 97 | <input type="checkbox"/> | <input type="checkbox"/> | |
| | 60,3 x 2,0 | 121 | <input type="checkbox"/> | <input type="checkbox"/> | |

- ungeschliffen, d. h. Rohr wird nach der Bearbeitung nicht nachgeschliffen
unground, i.e. tube is not reworked after processing
- Rohr nach dem Biegen nachschleifen, Korn 240
regrind after bending, 240 grit

Ihre Daten | your data:

Name _____

Telefon | phone _____

Firma | company _____

Fax _____

Straße | street _____

E-Mail _____

PLZ, Ort | city _____

Kundennummer | customer number _____

INFO

Maßangaben in Millimeter. Bitte bei der Bestellung beachten!
Dimensions are in millimetres. Please note when ordering!

Bitte kopieren, ausfüllen und an folgende Nummer faxen:
Please copy, complete and fax at no charge to
Fax: 0800 -3638-255





■ Handlauf Biegearbeiten | handrail bending work

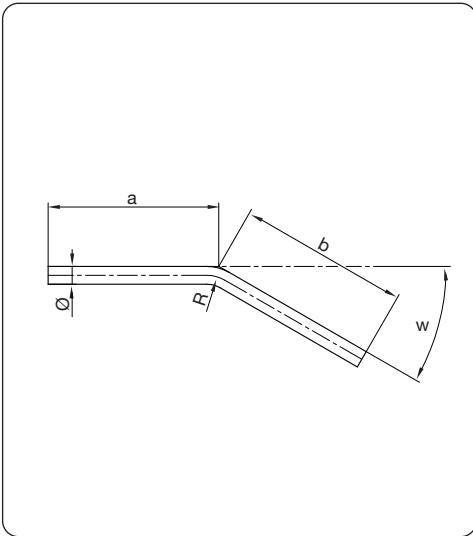

| Ausführung design | Ø | R | 304 (V2A) | 316 (V4A) | Stückzahl units |
|-------------------|------------|-----|--------------------------|--------------------------|-----------------|
| W _____ ° | 33,7 x 2,0 | 67 | <input type="checkbox"/> | <input type="checkbox"/> | |
| a _____ | 42,4 x 2,0 | 85 | <input type="checkbox"/> | <input type="checkbox"/> | |
| b _____ | 48,3 x 2,0 | 97 | <input type="checkbox"/> | <input type="checkbox"/> | |
| | 60,3 x 2,0 | 121 | <input type="checkbox"/> | <input type="checkbox"/> | |

- ungeschliffen, d. h. Rohr wird nach der Bearbeitung nicht nachgeschliffen
unground, i.e. tube is not reworked after processing
- Rohr nach dem Biegen nachschleifen, Korn 240
regrind after bending, 240 grit

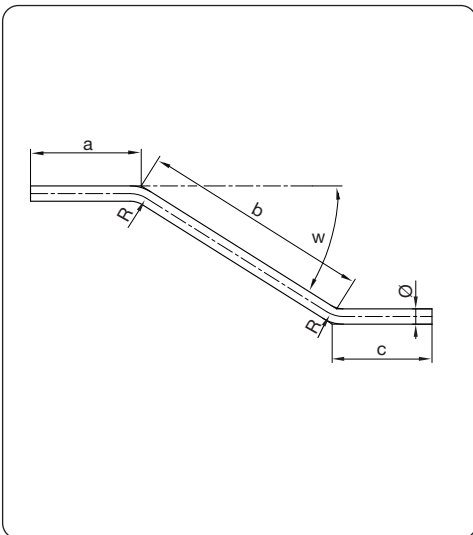

| Ausführung design | Ø | R | 304 (V2A) | 316 (V4A) | Stückzahl units |
|-------------------|------------|-----|--------------------------|--------------------------|-----------------|
| W _____ ° | 33,7 x 2,0 | 67 | <input type="checkbox"/> | <input type="checkbox"/> | |
| a _____ | 42,4 x 2,0 | 85 | <input type="checkbox"/> | <input type="checkbox"/> | |
| b _____ | 48,3 x 2,0 | 97 | <input type="checkbox"/> | <input type="checkbox"/> | |
| c _____ | 60,3 x 2,0 | 121 | <input type="checkbox"/> | <input type="checkbox"/> | |

- ungeschliffen, d. h. Rohr wird nach der Bearbeitung nicht nachgeschliffen
unground, i.e. tube is not reworked after processing
- Rohr nach dem Biegen nachschleifen, Korn 240
regrind after bending, 240 grit

Ihre Daten | your data:

Name _____

Telefon | phone _____

Firma | company _____

Fax _____

Straße | street _____

E-Mail _____

PLZ, Ort | city _____

Kundennummer | customer number _____

Bitte kopieren, ausfüllen und an folgende Nummer faxen:

Please copy, complete and fax at no charge to

Fax: 0 800 -36 38-255

INFO

Maßangaben in Millimeter. Bitte bei der Bestellung beachten!
Dimensions are in millimetres. Please note when ordering!



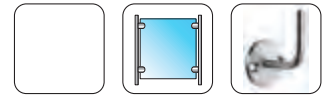

Biegearbeiten | bending work

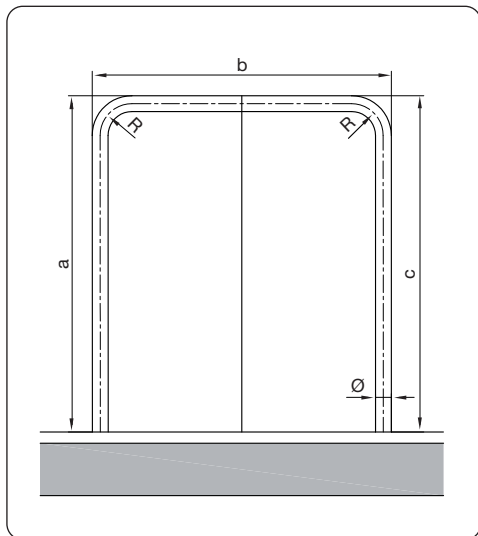

| Ausführung design | Ø | R | 304 (V2A) | 316 (V4A) | Stückzahl units |
|-------------------|------------|-----|--------------------------|--------------------------|-----------------|
| a _____ | 33,7 x 2,0 | 67 | <input type="checkbox"/> | <input type="checkbox"/> | |
| b _____ | 42,4 x 2,0 | 85 | <input type="checkbox"/> | <input type="checkbox"/> | |
| c _____ | 48,3 x 2,0 | 97 | <input type="checkbox"/> | <input type="checkbox"/> | |
| | 60,3 x 2,0 | 121 | <input type="checkbox"/> | | |

- ungeschliffen, d. h. Rohr wird nach der Bearbeitung nicht nachgeschliffen
unground, i.e. tube is not reworked after processing
- Rohr nach dem Biegen nachschleifen, Korn 240
regrind after bending, 240 grit

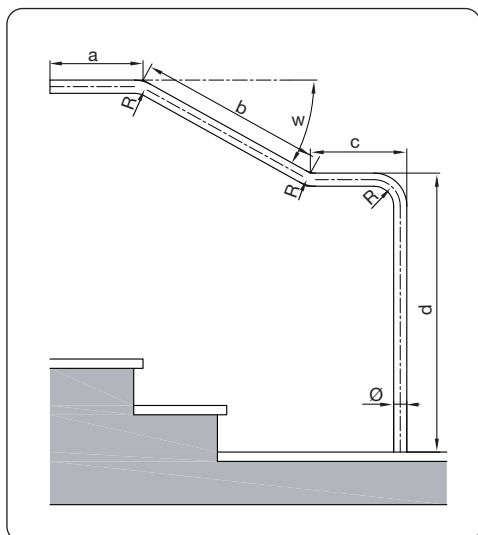

| Ausführung design | Ø | R | 304 (V2A) | 316 (V4A) | Stückzahl units |
|-------------------|------------|-----|--------------------------|--------------------------|-----------------|
| W _____ ° | 33,7 x 2,0 | 67 | <input type="checkbox"/> | <input type="checkbox"/> | |
| a _____ | 42,4 x 2,0 | 85 | <input type="checkbox"/> | <input type="checkbox"/> | |
| b _____ | 48,3 x 2,0 | 97 | <input type="checkbox"/> | <input type="checkbox"/> | |
| c _____ | 60,3 x 2,0 | 121 | <input type="checkbox"/> | | |
| d _____ | | | | | |

- ungeschliffen, d. h. Rohr wird nach der Bearbeitung nicht nachgeschliffen
unground, i.e. tube is not reworked after processing
- Rohr nach dem Biegen nachschleifen, Korn 240 | regrind after bending, 240 grit

Ihre Daten | your data:

Name

Telefon | phone

Firma | company

Fax

Straße | street

E-Mail

PLZ, Ort | city

Kundennummer | customer number

INFO

Maßangaben in Millimeter. Bitte bei der Bestellung beachten!
Dimensions are in millimetres. Please note when ordering!

Bitte kopieren, ausfüllen und an folgende Nummer faxen:
Please copy, complete and fax at no charge to
Fax: 0800 -3638-255





■ Biegearbeiten | bending work

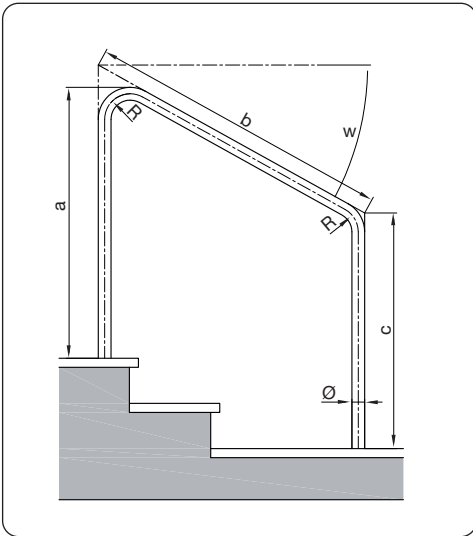

| Ausführung design | Ø | R | 304 (V2A) | 316 (V4A) | Stückzahl units |
|-------------------|------------|-----|--------------------------|--------------------------|-----------------|
| W _____ ° | 33,7 x 2,0 | 67 | <input type="checkbox"/> | <input type="checkbox"/> | |
| a _____ | 42,4 x 2,0 | 85 | <input type="checkbox"/> | <input type="checkbox"/> | |
| b _____ | 48,3 x 2,0 | 97 | <input type="checkbox"/> | <input type="checkbox"/> | |
| c _____ | 60,3 x 2,0 | 121 | <input type="checkbox"/> | | |

- ungeschliffen, d. h. Rohr wird nach der Bearbeitung nicht nachgeschliffen
unground, i.e. tube is not reworked after processing
- Rohr nach dem Biegen nachschleifen, Korn 240
regrind after bending, 240 grit

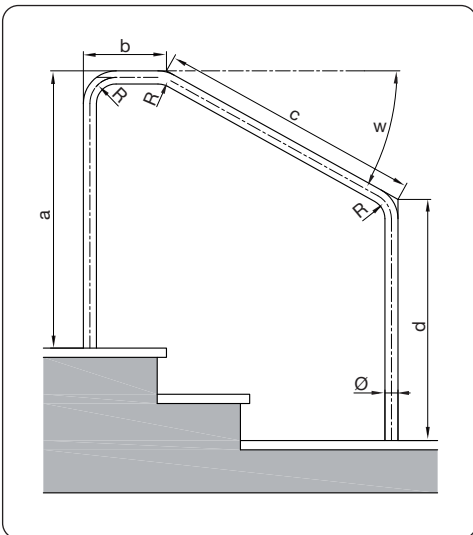

| Ausführung design | Ø | R | 304 (V2A) | 316 (V4A) | Stückzahl units |
|-------------------|------------|-----|--------------------------|--------------------------|-----------------|
| W _____ ° | 33,7 x 2,0 | 67 | <input type="checkbox"/> | <input type="checkbox"/> | |
| a _____ | 42,4 x 2,0 | 85 | <input type="checkbox"/> | <input type="checkbox"/> | |
| b _____ | 48,3 x 2,0 | 97 | <input type="checkbox"/> | <input type="checkbox"/> | |
| c _____ | 60,3 x 2,0 | 121 | <input type="checkbox"/> | | |
| d _____ | | | | | |

- ungeschliffen, d. h. Rohr wird nach der Bearbeitung nicht nachgeschliffen
unground, i.e. tube is not reworked after processing
- Rohr nach dem Biegen nachschleifen, Korn 240 | regrind after bending, 240 grit

Ihre Daten | your data:

Name _____

Telefon | phone _____

Firma | company _____

Fax _____

Straße | street _____

E-Mail _____

PLZ, Ort | city _____

Kundennummer | customer number _____

Bitte kopieren, ausfüllen und an folgende Nummer faxen:
Please copy, complete and fax at no charge to

Fax: 0800 -3638-255

INFO

Maßangaben in Millimeter. Bitte bei der Bestellung beachten!
Dimensions are in millimetres. Please note when ordering!



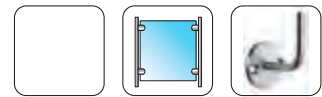

Biegearbeiten | bending work

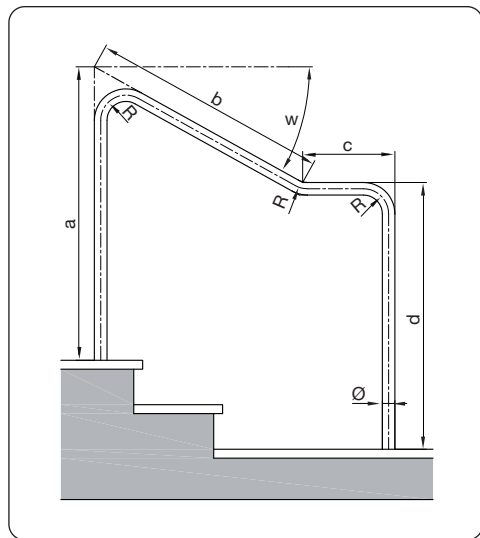

| Ausführung design | Ø | R | 304 (V2A) | 316 (V4A) | Stückzahl units |
|-------------------|------------|-----|--------------------------|--------------------------|-----------------|
| W _____ ° | 33,7 x 2,0 | 67 | <input type="checkbox"/> | <input type="checkbox"/> | |
| a _____ | 42,4 x 2,0 | 85 | <input type="checkbox"/> | <input type="checkbox"/> | |
| b _____ | 48,3 x 2,0 | 97 | <input type="checkbox"/> | <input type="checkbox"/> | |
| c _____ | 60,3 x 2,0 | 121 | <input type="checkbox"/> | | |
| d _____ | | | | | |

ungeschliffen, d.h. Rohr wird nach der Bearbeitung nicht nachgeschliffen
 unsanded i.e. tube is not reworked after processing
 Rohr nach dem Biegen nachschleifen, Korn 240 | sanded after bending, 240 grit

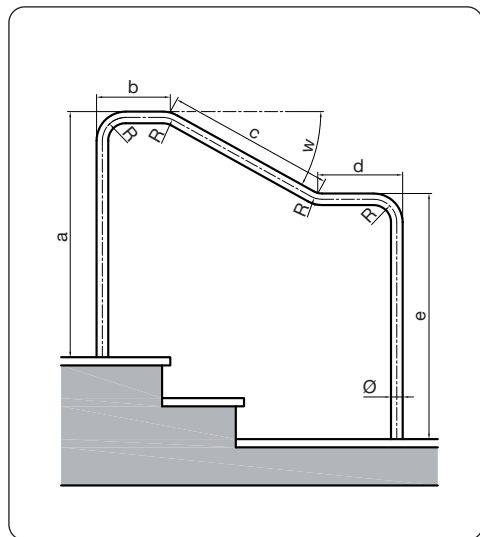

| Ausführung design | Ø | R | 304 (V2A) | 316 (V4A) | Stückzahl units |
|-------------------|------------|-----|--------------------------|--------------------------|-----------------|
| W _____ ° | 33,7 x 2,0 | 67 | <input type="checkbox"/> | <input type="checkbox"/> | |
| a _____ | 42,4 x 2,0 | 85 | <input type="checkbox"/> | <input type="checkbox"/> | |
| b _____ | 48,3 x 2,0 | 97 | <input type="checkbox"/> | <input type="checkbox"/> | |
| c _____ | 60,3 x 2,0 | 121 | <input type="checkbox"/> | | |
| d _____ | | | | | |
| e _____ | | | | | |

ungeschliffen, d.h. Rohr wird nach der Bearbeitung nicht nachgeschliffen
 unsanded i.e. tube is not reworked after processing
 Rohr nach dem Biegen nachschleifen, Korn 240 | sanded after bending, 240 grit

Ihre Daten | your data:

Name _____

Telefon | phone _____

Firma | company _____

Fax _____

Straße | street _____

E-Mail _____

PLZ, Ort | city _____

Kundennummer | customer number _____

INFO

Maßangaben in Millimeter. Bitte bei der Bestellung beachten!
 Dimensions are in millimetres. Please note when ordering!

Bitte kopieren, ausfüllen und an folgende Nummer faxen:
 Please copy, complete and fax at no charge to
Fax: 0800 -3638-255





Formular für Sonderanfertigungen | custom order sheet

Bitte kopieren, ausfüllen und an folgende Nummer faxen:
 Please copy, complete and fax at no charge to
 Fax: 0800 -3638-255

Ihre Daten | your data:

Kundennummer | customer number

Firma | company

Ansprechpartner | contacts

Straße | street

PLZ, Ort | city

Telefon | phone

E-Mail

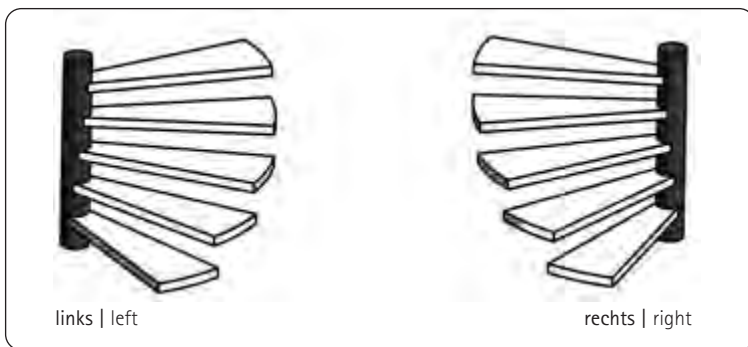
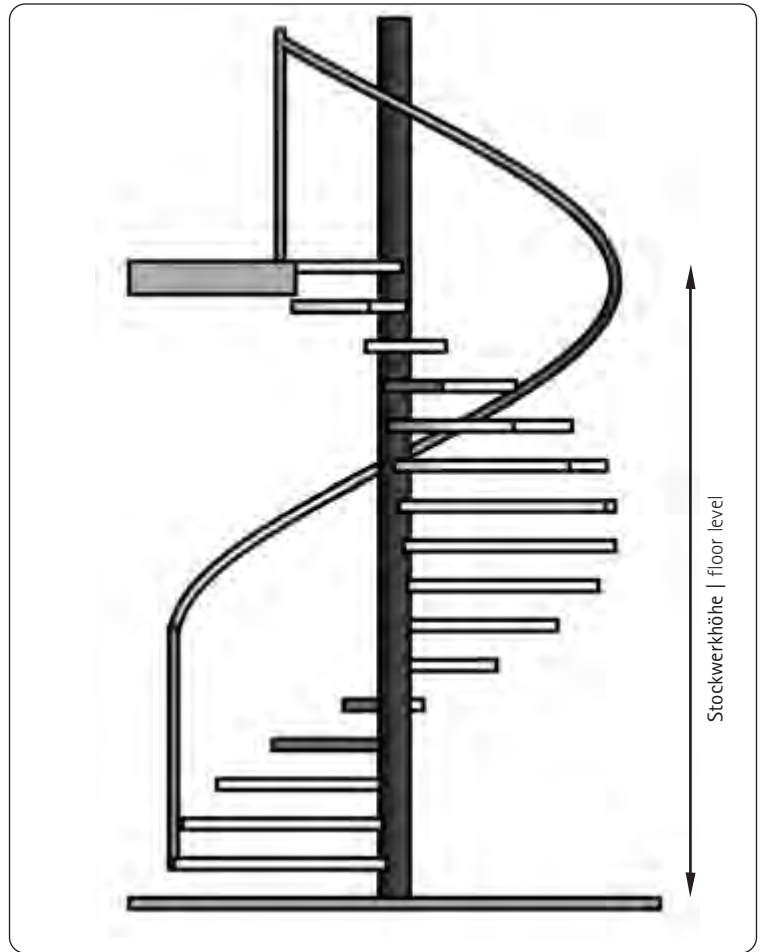

Treppen-Parameter | Stairs parameters:

(Bitte alle Maße in mm eintragen) | (Please indicate all dimensions in mm)

- links | left
- rechts | right

Rohr \emptyset | tube \emptyset

Stockwerkhöhe | floor level

Steigungshöhe | rise

Stufenanzahl | tread quantity

Auftrittsbreite | tread width

Treppenradius | staircase radius

Material | material

Stückzahl | units

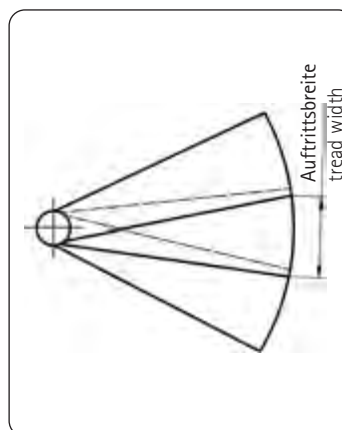
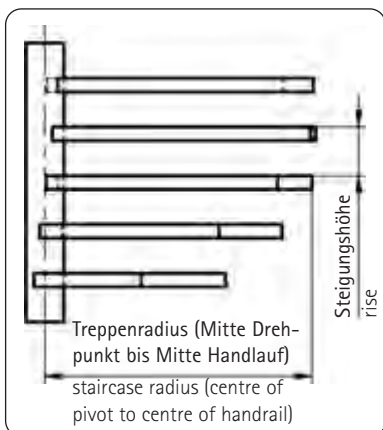





■ Inhalt | content



- Pfostensets mit Glasklemmen 202
post sets with glass clamps
- Pfostensets mit Lochblechhaltern 203
post sets with sheet holders
- Pfostensets mit Klemmen cp-mini 204
post sets with cp-mini clamps
- Pfostensets mit Querstabhaltern 205
post sets with cross bar holders
- Pfostensets mit Banano | post sets with Banano 206
- Pfostensets aus Flachstahl | post sets with flat bar 207

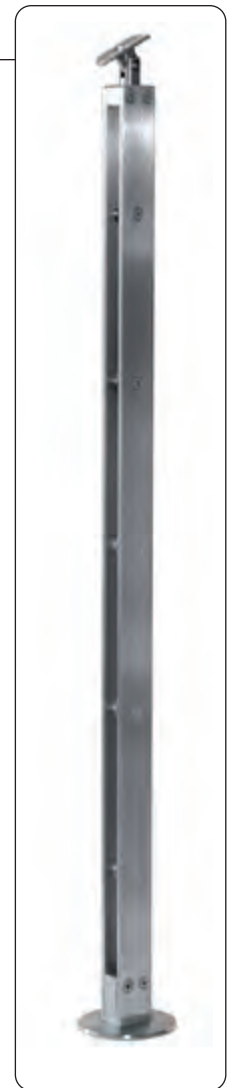

INFO

Pfostensets sind auf Anfrage auch in anderen Abmessungen lieferbar.
Post sets can also be supplied in other dimensions on request.



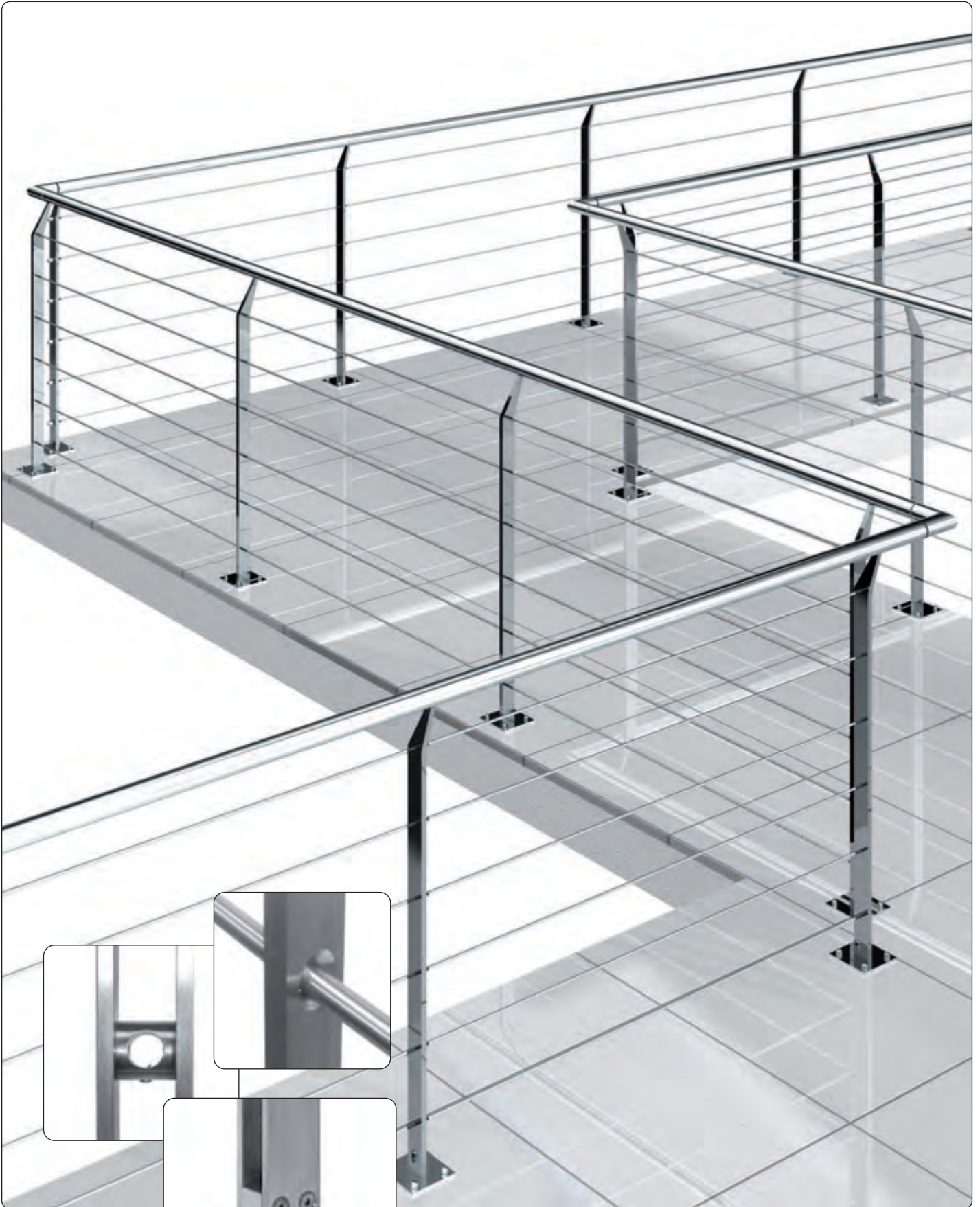

■ Fertigpostenprogramm
prefabricated posts





■ Pfostensets mit Glasklemmen
post sets with glass clamps

VERSCHRAUBUNG
SCREW CONNECTIONS

Ansicht für die Verschraubung.
Dies gilt für alle Rundrohr
Pfostensets. | Screw connection
diagram. Pertains to all round
tube post sets.

INFO

Sämtliche Pfosten können
in Größe, Dimension und
Bestückung auf Kundenan-
forderung angeboten
werden.
All posts can be offered
to customers' requirements
in size, dimension and
assembly.

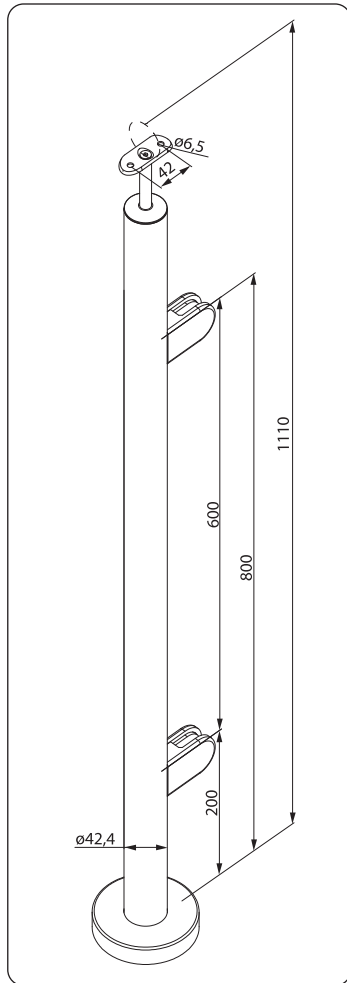

Art. Nr. 11 94 25 00

Pfostenset mit Glasklemmen
Anfangspfosten | post set with
glass clamps, starting post

Material | material V2A (1.4301)
=○ 42,4 x 2,0 mm

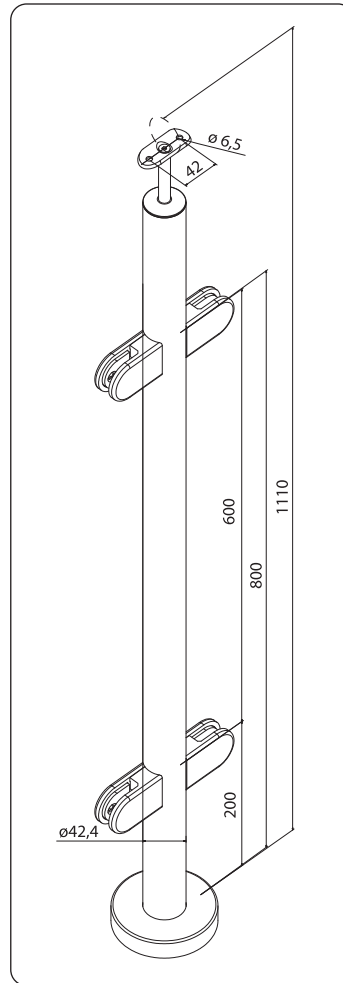

Art. Nr. 11 94 26 00

Pfostenset mit Glasklemmen
Mittelpfosten | post set with glass
clamps, middle post

Material | material V2A (1.4301)
=○ 42,4 x 2,0 mm

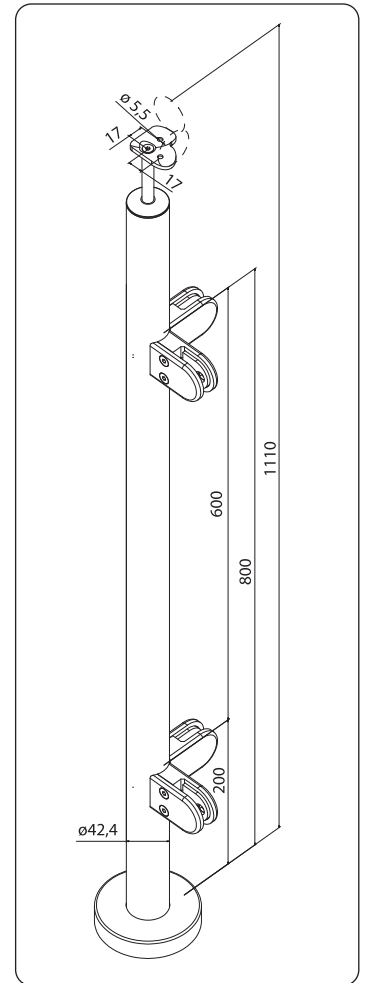

Art. Nr. 11 94 27 00

Pfostenset mit Glasklemmen
Eckpfosten | post set with glass
clamps, corner post

Material | material V2A (1.4301)
=○ 42,4 x 2,0 mm





■ Pfostensets mit Lochblechhaltern
post sets with sheet holders

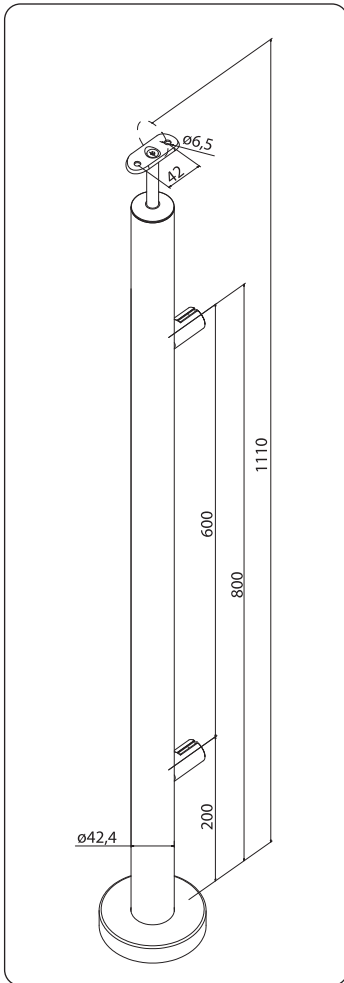

Art. Nr. 11 94 28 00

Pfostenset mit Lochblechhaltern
Anfangspfosten | post set with
sheet holders, starting post

Material | material V2A (1.4301)
=○ 42,4 x 2,0 mm

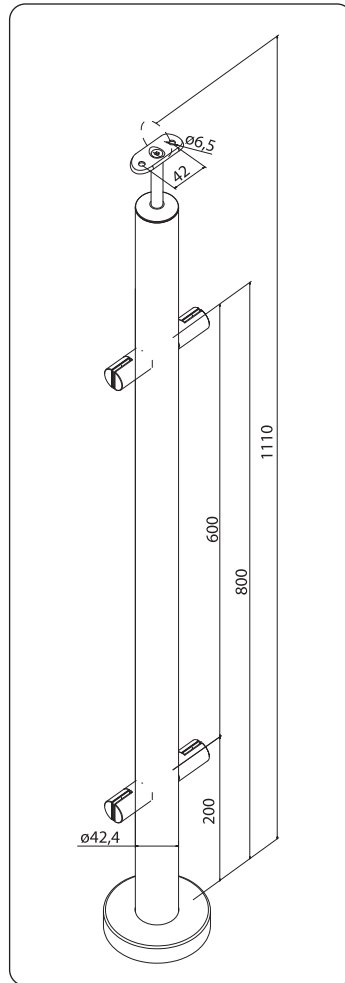

Art. Nr. 11 94 29 00

Pfostenset mit Lochblechhaltern
Mittelpfosten | post set with sheet
holders, middle post

Material | material V2A (1.4301)
=○ 42,4 x 2,0 mm

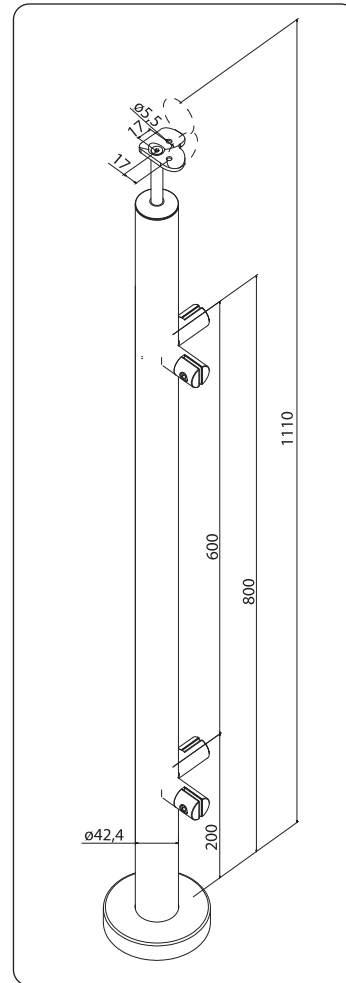

Art. Nr. 11 94 30 00

Pfostenset mit Lochblechhaltern
Eckpfosten | post set with sheet
holders, corner post

Material | material V2A (1.4301)
=○ 42,4 x 2,0 mm

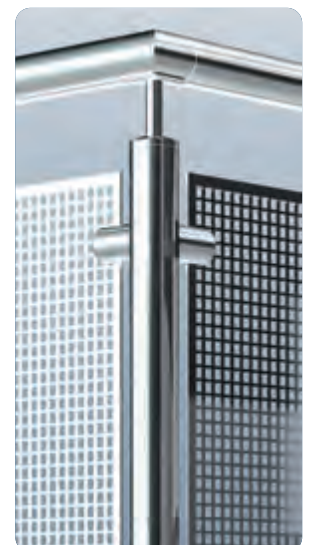
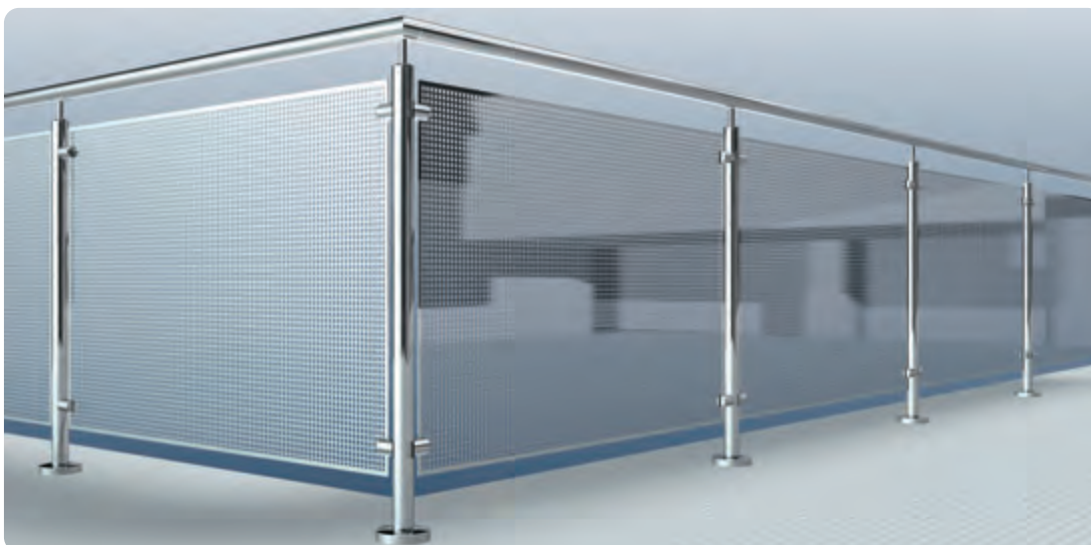



■ Pfostensets mit Klemmen cp-mini
post sets with cp-mini clamps

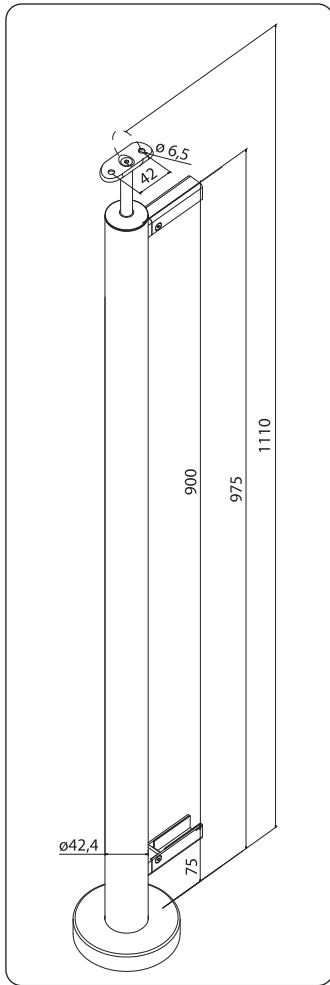

Art. Nr. 11 94 46 00

Pfostenset Ende
end post set,

Material | material V2A (1.4301)
≡○ 42,4 x 2,0 mm

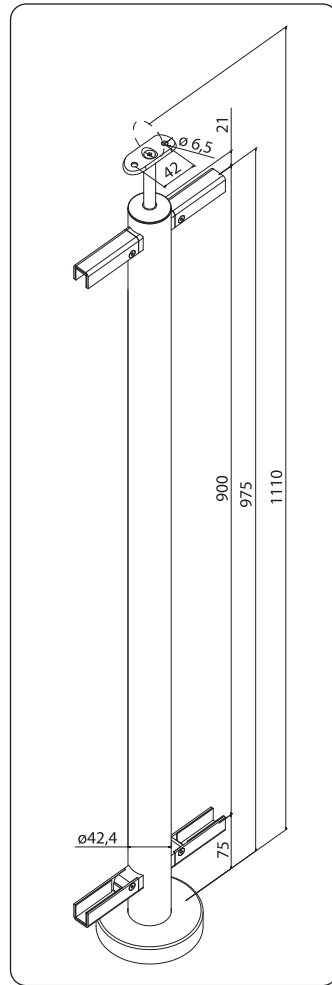

Art. Nr. 11 94 47 00

Pfostenset Mitte
middle post set

Material | material V2A (1.4301)
≡○ 42,4 x 2,0 mm

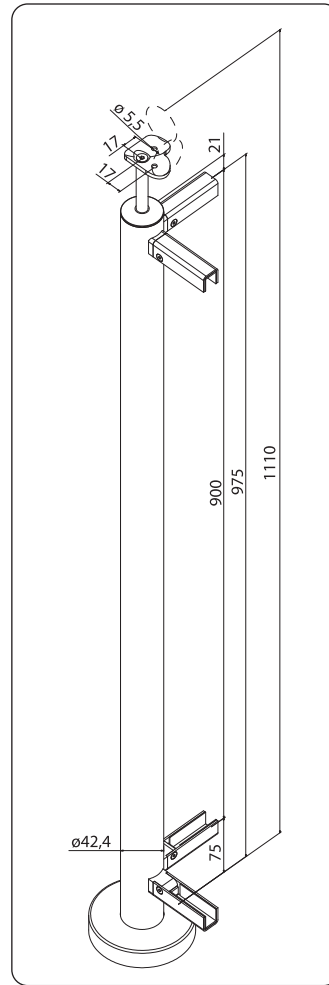

Art. Nr. 11 94 48 00

Pfostenset Ecke
corner post set

Material | material V2A (1.4301)
≡○ 42,4 x 2,0 mm

■ Pfostensets mit
Querstabhaltern

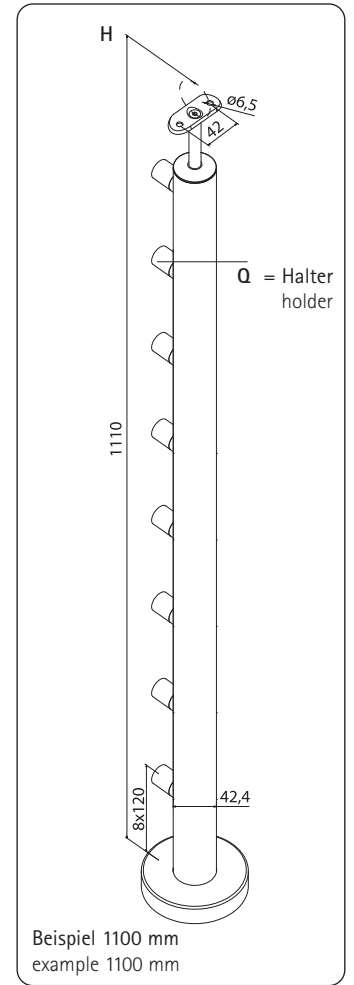

Beispiel 1100 mm
example 1100 mm

Set

Pfostenset Ende links
end post set, left

Material | material V2A (1.4301)
≡○ 42,4 x 2,0 mm

Art. Nr. 11 94 31 00

H 1100 mm

Q 8 Stück | pieces

Art. Nr. 11 94 36 00

H 1000 mm

Q 7 Stück | pieces

Art. Nr. 11 94 41 00

H 900 mm

Q 6 Stück | pieces





■ Pfostensets mit Querstabhaltern
post sets with cross bar holders

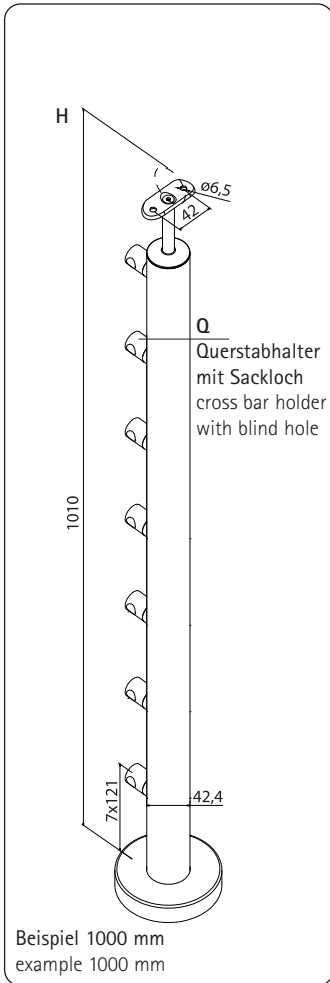

Set
Pfostenset Ende rechts
end post set, right
Material | material V2A (1.4301)
=O 42,4 x 2,0 mm

Art. Nr. 11 94 32 00
H 1100 mm
Q 8 Stück | pieces

Art. Nr. 11 94 37 00
H 1000 mm
Q 7 Stück | pieces

Art. Nr. 11 94 42 00
H 900 mm
Q 6 Stück | pieces

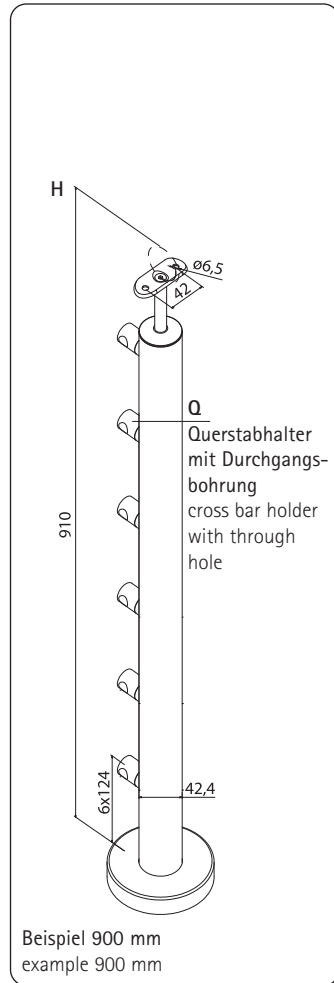

Set
Pfostenset Mitte
middle post set
Material | material V2A (1.4301)
=O 42,4 x 2,0 mm

Art. Nr. 11 94 33 00
H 1100 mm
Q 8 Stück | pieces

Art. Nr. 11 94 38 00
H 1000 mm
Q 7 Stück | pieces

Art. Nr. 11 94 43 00
H 900 mm
Q 6 Stück | pieces

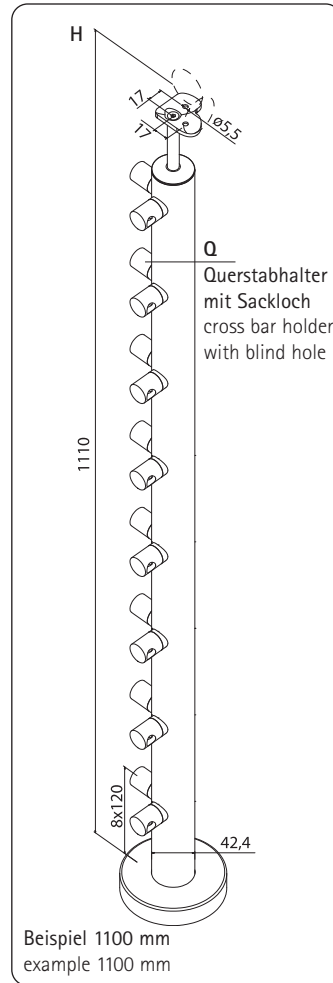

Set
Pfostenset Ecke
corner post set
Material | material V2A (1.4301)
=O 42,4 x 2,0 mm

Art. Nr. 11 94 34 00
H 1100 mm
Q 16 Stück | pieces

Art. Nr. 11 94 39 00
H 1000 mm
Q 14 Stück | pieces

Art. Nr. 11 94 44 00
H 900 mm
Q 12 Stück | pieces

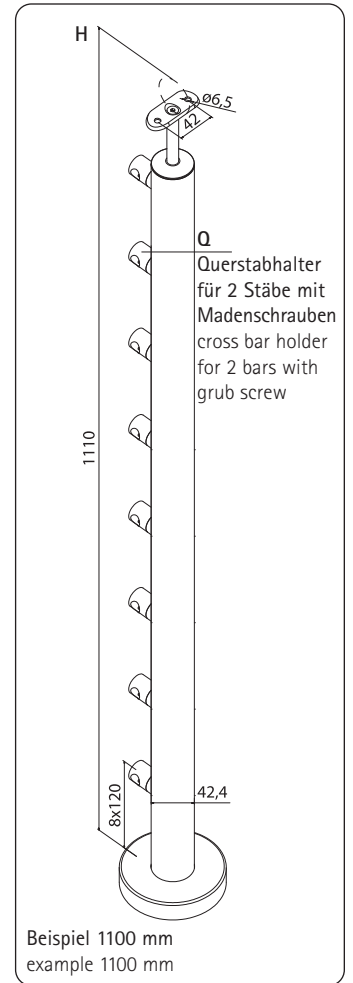

Set
Pfostenset Mitte mit Verbinder
middle post set with connector
Material | material V2A (1.4301)
=O 42,4 x 2,0 mm

Art. Nr. 11 94 35 00
H 1100 mm
Q 8 Stück | pieces

Art. Nr. 11 94 40 00
H 1000 mm
Q 7 Stück | pieces

Art. Nr. 11 94 45 00
H 900 mm
Q 6 Stück | pieces





■ Pfostenets mit Banano
post sets with Banano

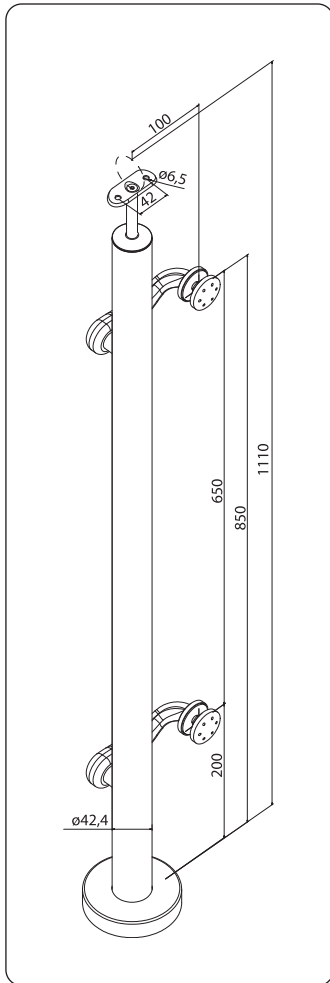

Art. Nr. 11 94 49 00

Pfostenset Ende links
end post set, left

Material | material V2A (1.4301)
≡○ 42,4 x 2,0 mm

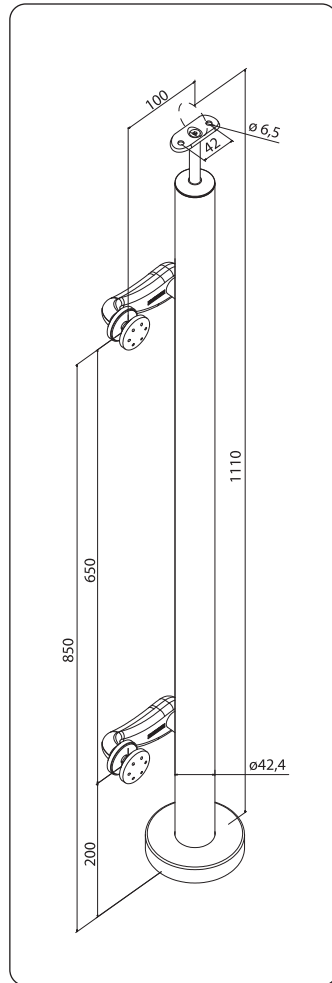

Art. Nr. 11 94 50 00

Pfostenset Ende rechts
end post set, right

Material | material V2A (1.4301)
≡○ 42,4 x 2,0 mm

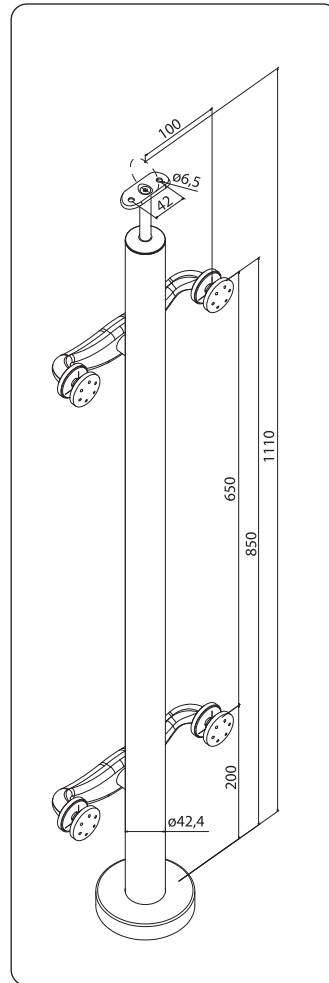

Art. Nr. 11 94 51 00

Pfostenset Mitte
middle post set

Material | material V2A (1.4301)
≡○ 42,4 x 2,0 mm

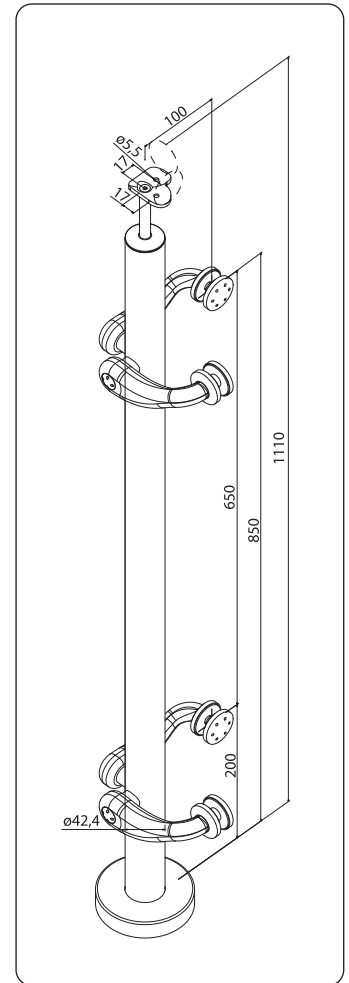

Art. Nr. 11 94 52 00

Pfostenset Ecke
corner post set

Material | material V2A (1.4301)
≡○ 42,4 x 2,0 mm





■ Pfostensets aus Flachstahl
post sets with flat bar



Art. Nr. 11 94 53 00

Pfostenset V2A aus Flachstahl, mit 5 Querstabhaltern Ø 12,2 mm, 964 mm Höhe, Handlaufträger für Ø 42,4 und Bodenanschluss.
post set VA2, flat bar, with 5 cross bar holders Ø12.2 mm, 964 mm high, handrail support for Ø42.4 mm, floor mounting.



Art. Nr. 11 94 54 00

Pfostenset V2A aus Flachstahl, mit 5 Querstabhaltern Ø 12,2 mm, 1333 mm Höhe, Handlaufträger für Ø 42,4 und Wandanschluss.
post set VA2, flat bar, with 5 cross bar holders Ø12.2 mm, 1333mm high, handrail support for Ø42.4 mm and wall mounting.

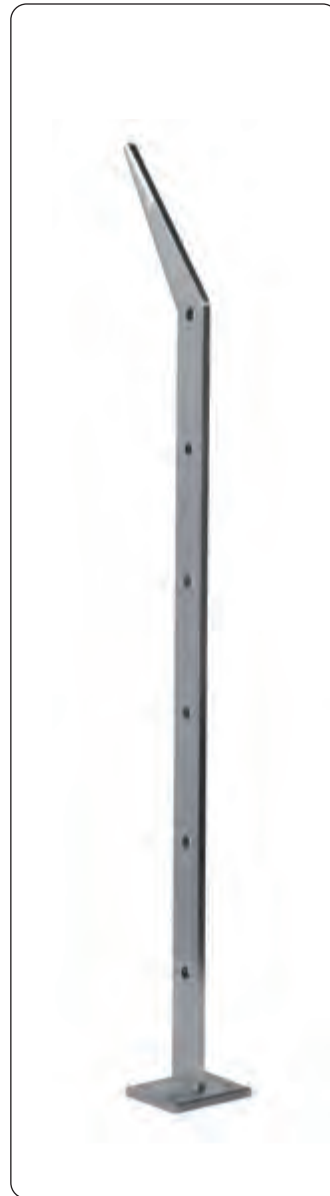

Art. Nr. 11 94 55 00

Pfostenset V2A, 180°, 6-fach gelocht für Rundstab Ø12mm, geknickte Aufnahme, 1000 mm Höhe
post set VA2, flat bar, 6 holes for round bar Ø12.2mm, 1000mm high



Art. Nr. 11 94 57 00

Pfostenset V2A gebeugt, mit Querstabhaltern, Bohrung Ø12,2 mm; Höhe 1000 mm, Aufnahme Ø42,4 mm
post set VA2, curved, with 7 cross bar holders Ø12.2 mm, 1000 mm high, handrail support for Ø42.4 mm.



Art. Nr. 11 94 56 00

Pfostenset V2A gebogen, mit Querstabhaltern mit Bohrung Ø12,2 mm; Höhe 1000 mm, Aufnahme Ø42,4 mm
post set VA2, curved, with 6 cross bar holders with bore Ø12.2 mm, 1000 mm high, handrail support for Ø42.4 mm.



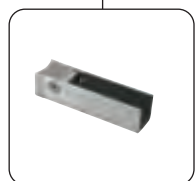
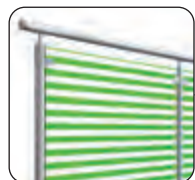

- Bemessung und Sicherheit bei Brüstungen 209-249
design and safety of balustrade
- Brüstungsbaukasten | balustrade building blocks 210-213
- Beispiele | examples 214-215
- Sicherheit bei Geländern | railing safety 216
- Planungsablauf und zeitlicher Aufwand 217
planning process and time required
- Richtig planen | plan correctly 218
- Nachweis Brüstung | balustrade verification 219
- Belastungen | loads 220-221
- Nachweis Pfosten/Handlauf 222
posts/handrail verification
- Nachweis der Klemmen und Füllung AbZ Z-70.2-28 223-229
clamp and infill verification AbZ Z-70.2-28
- Checkliste Klemmbefestigungen für die 230-231
Verbauung im Außenbereich AbZ Z-70.2-28
- Eingeführte technische Baubestimmungen 232
implemented technical building regulations
- ETB mit TRESPA® Füllungen | ETB with TRESPA® panel infills 232
- Einsatzgebiet TRESPA® | TRESPA® applications 233
- Banano mit Prüfzeugnis 234-235
Banano with test certificate
- TRAV (Technische Regeln für die Verwendung absturzsichernder
Verglasungen) | TRAV (technical rules for safety balustrades) 236-237
- Brüstungsverglasung nach TRAV 238-241
balustrade glazing according to TRAV
- Zustimmung im Einzelfall | individual approval 242
- Brüstungen mit cp-mini 242-243
balustrade clamp: cp-mini
- Französischer Balkon ohne Handlauf 243
french balcony without hand rail
- Weitere Alternativen | other alternatives 244-245
- Farbigkeit | colours 246-247
- Anwendungen | applications 248-249



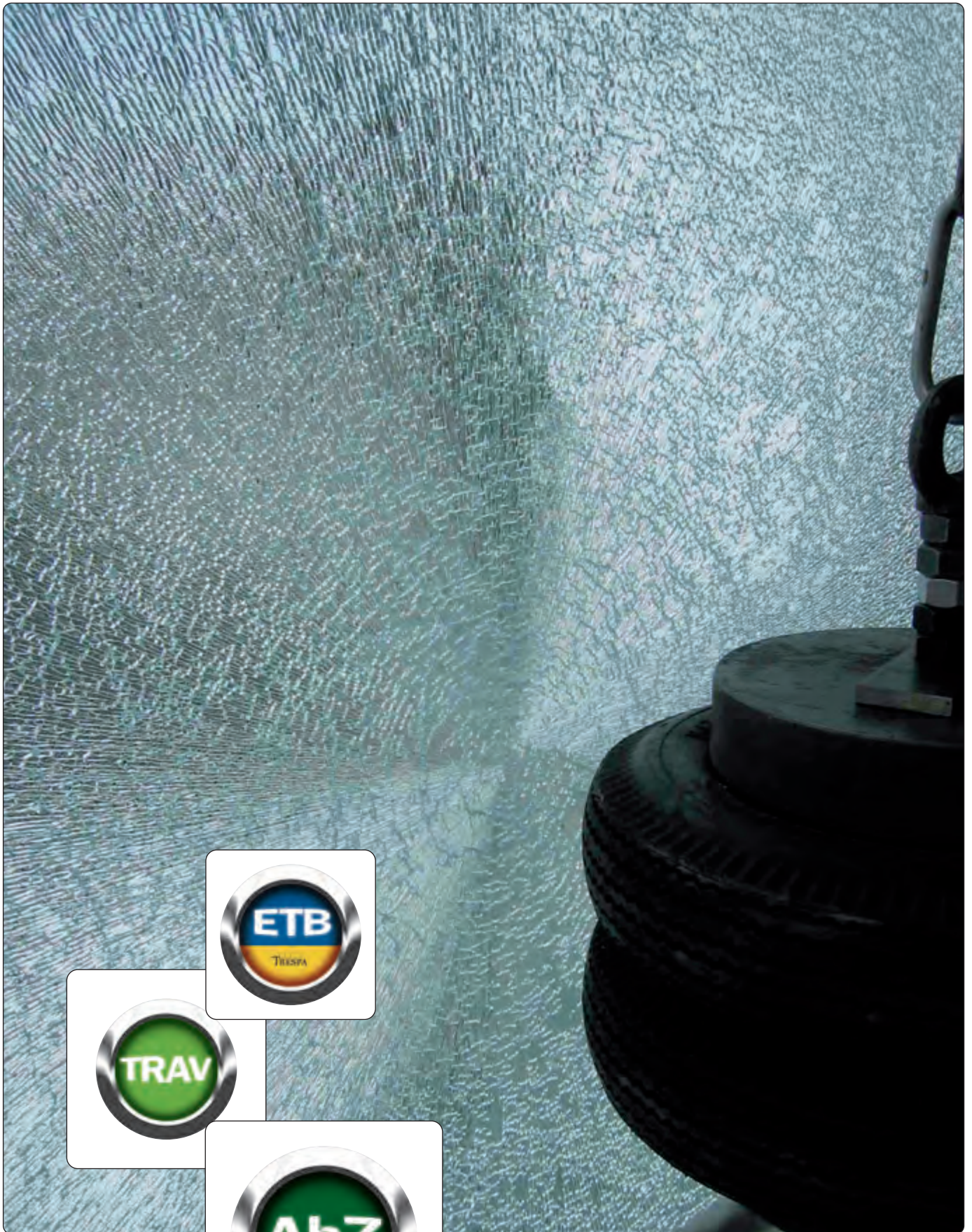

- Bemessung und Sicherheit bei Brüstungen
design and safety of balustrade

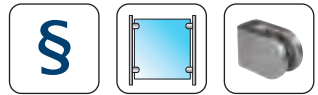



Brüstungsbaukasten | balustrade building blocks

■ Welche Brüstungen sind möglich? | Which balustrades are possible?

Eine Brüstung besteht aus vielen Einzelteilen. Am Anfang dieses Kapitels finden Sie eine Hilfestellung mit einem Überblick über die verschiedenen Bestandteile und welche Anwendungen sich damit realisieren lassen.

A balustrade is made up of many individual parts. This chapter starts with an overview of the various components and the applications which can be realised with them.

3. Witterungseinfluss
effect of the weather

2. Möglichkeiten
possibilities





Vielfältig | multifaceted:

- Galerie | gallery
- Treppe | stairs
- Balkon | balcony
- ...



1. Konstruktionsart
construction types

- absturzsichernd nach TRAV (Kat. C1, B)
safety barrier glazing According to TRAV (Cat. C1, B)
- Französischer Balkon
French balcony
- Windschutz | wind break



4. Befestigung der Füllung
infill attachment





5. Pfosten | posts





6. Anschlusskappen und
Verbinder | terminal caps
and connectors



7. Verankerung am Boden
floor anchoring





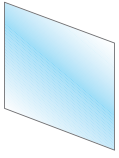

8. Handläufe | handrails

9. Füllung | infill

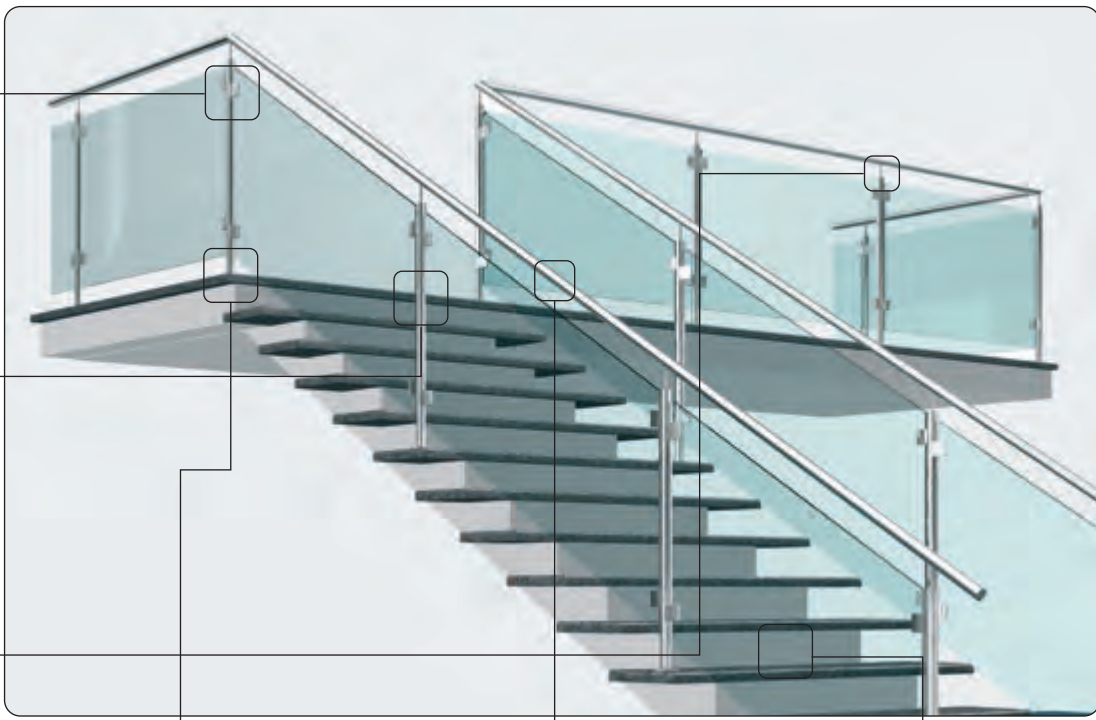



Brüstungsbaukasten | balustrade building blocks

1. Konstruktionsart | construction type

Mit unseren Brüstungssystemen lässt sich eine Vielzahl von Brüstungen realisieren. Hier nur eine kleine Auswahl:
A multitude of balustrades can be realised with our balustrade systems. A small selection is shown below:



Kategorie C1 nach TRAV sowie ausfachende Verglasung mit AbZ
category C1 in accordance with TRAV and infill glazing with national technical approval (AbZ)



Kategorie B nach TRAV, unten eingespannt, aufgesteckter Handlauf | category B in accordance with TRAV, cantilever mounted with attached handrail



Französischer Balkon ohne Handlauf | French balcony without a handrail



Windschutz nicht absturzsichernd, Seite 298
wind break, not effective as a safety barrier, page 298

2. Möglichkeiten | possibilities



Galerie | gallery



Treppe | stairs



Treppenauge | stair well



Balkon | balcony

3. Witterungseinfluss | effect of the weather















Unsere Brüstungen sind sowohl für den Innen- als auch für den Außenbereich einsetzbar.
Our balustrades are suitable for both indoor and outdoor use.



Brüstungsbaukasten | balustrade building blocks





4. Befestigung der Füllung | infill attachment

| | Sicherheit safety | Füllung infill | Produkte ab Seite products from page |
|--|--|------------------|---|
|  Klemmbefestigungen clamp fixtures |  | Glas glass | 16 |
|  Klemmbefestigungen clamp fixtures |  | TRESPA® | 16 |
|  TRAV-Halter TRAV fixtures |  | Glas glass | 52 |
|  Banano |  | Glas glass | 58 |
|  Plattenhalter panel holders |  | Metall metal | 147 |
|  Seilhalter cable supports | | Seile cables | 175 |
|  Querstabträger cross bar holders | | Stäbe bars | 142 |
|  cp-mini cp-mini |  | Glas glass | 46 |



5. Pfosten | posts

| | Durchmesser in mm diameter in mm | Seite page |
|--|-------------------------------------|---------------|
|  Rundrohrpfosten round tube post | d = 33,7 42,4 48,3 60,3 | 72 |
|  Quadratpfosten square post | a x b = 30 x 30 40 x 40 | 73 |
|  Flacheisen flat bars | a x b = 40 x 20 | 207 |



6. Anschlusskappen und Verbinder | terminal caps and connectors



Mehr Kappen auf Seite: 74-79
more caps on page: 74-79



Mehr Verbinder auf Seite: 98-109
more connectors on page: 98-109



Brüstungsbaukasten | balustrade building blocks

7. Verankerung am Boden | floor anchoring



Aufsatzmontage
floor mounting



Vorsatzmontage
fascia mounting



Unterkoffermontage
underside mounting



Bodenanker
standard post anchor



Bodenanker verstärkt
für Rundrohrpfosten
Ø 38 mm | Reinforced
post anchor for round
tube posts Ø 38 mm



Bodenanker verstärkt
für Rundrohrpfosten
Ø 44 mm | Reinforced
post anchor for round
tube posts Ø 44 mm

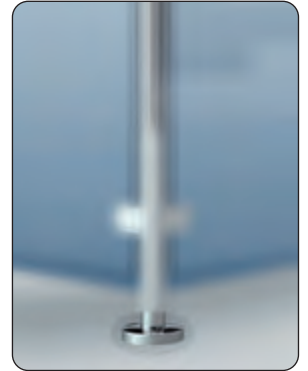

8. Handläufe | handrails

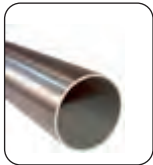

Edelstahl
stainless steel
Seite 72, 126
page 72, 126



Holz
wood
ab Seite 128
from page 128



9. Füllung | infill



AbZ mit Glasfüllung ab Seite 223
AbZ with glass infills from page 223



mit Stäben ab Seite 244-245
with bars from page 244-245



mit Seilen ab Seite 244-245
with cables from page 244-245



ETB mit Lochblechen ab Seite 244-245
ETB with perforated sheets from page
244-245



ETB mit TRESPA® ab Seite 232
ETB with TRESPA® from page 232

SERVICE

Fordern Sie unsere
Aufmaßblätter an!

Request our dimensioning
sheets!

Klemme mit AbZ

Glasaufbau ab Seite 223
Pfostenabstand
siehe Seite 222

clamp with national
technical approval (AbZ)
glass structure, see page 223
post spacing, see page 222

Beispiele | examples

- So wählen Sie Ihre Wunschbrüstung aus | How to choose your desired balustrade

Beispiel 1 | example 1

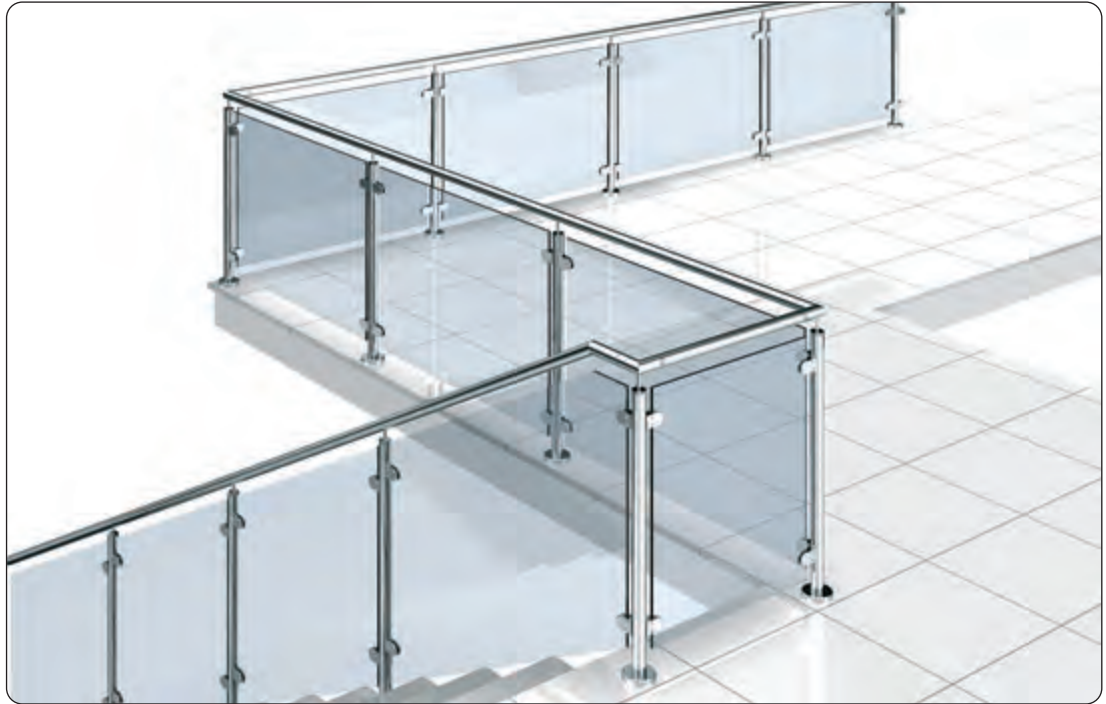

Beispiel 2 | example 2

Banano mit AbP

Glasaufbau siehe Seite 235
Pfostenabstand
siehe Seite 222

Banano with general test
certificate from building
authorities (AbP)
glass structure, see page 235
post spacing, see page 222





Beispiel 3 | example 3

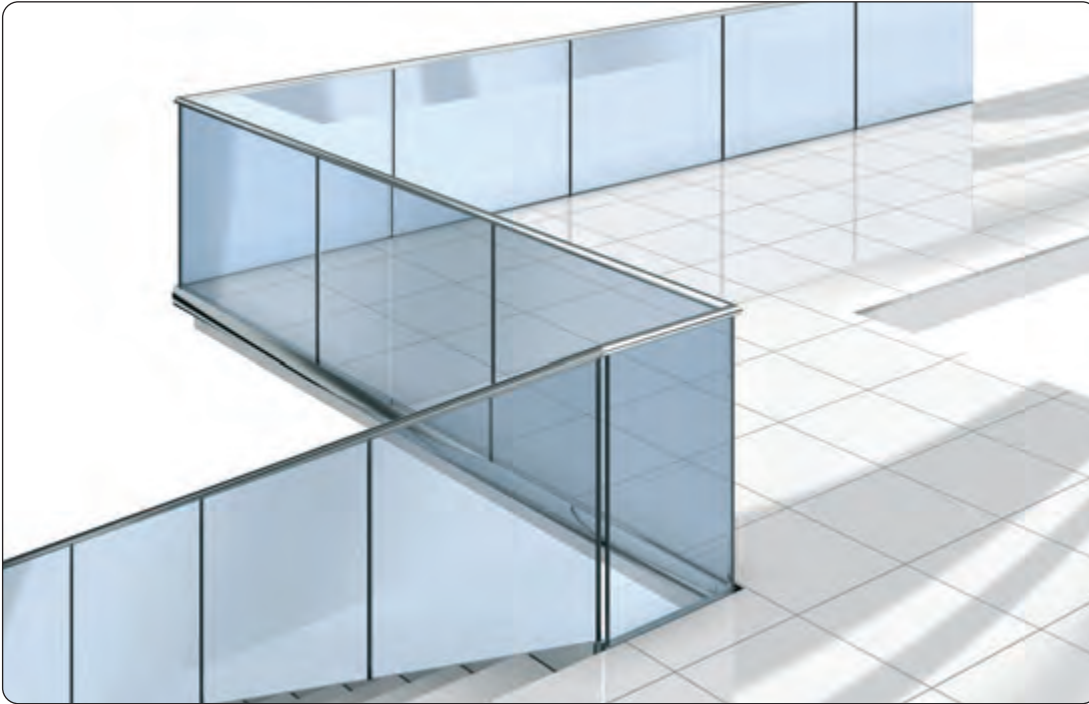

Kategorie B
Glasaufbau siehe Seite 240
Scheibenbreite
siehe Seite 240

category B
glass structure, see page 240
Panel width, see page 240

Beispiel 4 | example 4



TRAV-Halter
Glasaufbau siehe Seite 239
Pfostenabstand
siehe Seite 222

TRAV fixtures
glass structure, see page 239
post spacing, see page 222

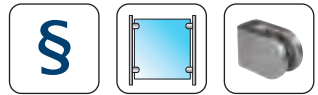

Sicherheit bei Geländern | railing safety

- Verschiedene Richtlinien und Zulassungen im Überblick
 An overview of different guidelines and approvals



Im öffentlichen, aber auch im privaten Bereich werden hohe Anforderungen an die Sicherheit gestellt. Deshalb durchlaufen unsere Produkte sowohl interne Tests als auch Prüfungen durch externe, unabhängige Prüfinstitute. Unsere Brüstungsverglasungen mit Klemmen verfügen über eine AbZ (Z-70.2-28), der Banano-Halter besitzt ein AbP.

There are high demands on safety in public and private areas. That is why our products are tested in-house and by independent external testing institutes. We have national technical approval (AbZ Z-70.2-28) for our glass balustrades with clamps as well as an and a general test certificate from building authorities (AbP) for our Banano fixture system.



Die Technischen Regeln für die Verwendung von absturzsichernden Verglasungen regeln die Verbauung von absturzsichernden Verglasungen. Beispielsweise die Anwendung von punktförmig gelagerten Scheiben (Kategorie C1) beschränkt sich auf den Innenbereich, die Befestigung der Glasfüllung erfolgt über Punkthalter mit verschiedenen Tellerdurchmessern.

The technical rules for the use of glass safety barriers regulate the construction of such barriers. Pointed, installed glass panels (category C1) may only be used indoors. The glass infills are mounted using point fixings with different plate diameters.



Mit der Allgemeinen bauaufsichtlichen Zulassung wird die Verwendbarkeit bzw. Anwendbarkeit von unregulierten Bauarten, wie z. B. Brüstungsverglasungen mit Klemmaltern aus Glas, nachgewiesen. Die Erleichterung für Planer und Handwerker ergibt sich dadurch, dass i. d. R. keine weiteren Statiken und Bauteilversuche mehr benötigt werden. Die AbZ ist für ganz Deutschland gültig.

The usefulness and applicability of unregulated construction types, such as balustrade glazing with glass clamp fixtures, is verified with the national technical approval. This makes it easier for planners and builders because no further statics or component tests are usually required. The AbZ applies across all of Germany.



Das Allgemeine bauaufsichtliche Prüfzeugnis dokumentiert die Übereinstimmung mit den Anforderungen einer technischen Regel. Nachgewiesen wird diese durch Prüfung einer anerkannten Prüfstelle. Für das Beispiel punktförmig gelagerte, ausfachende Verglasung gemäß TRAV (Kategorie C1) gilt das AbP nur für den Innenbereich. AbPs werden beispielsweise für Verglasungen, die in der TRAV geregelt sind, ausgestellt.

The general test certificate from building authorities (AbP) documents compliance requirements of a technical regulation. This is verified by certified inspectorates. In the case of pointed glass infills under TRAV (category C1), for example, the AbP applies to indoor use only. AbP's are issued for glazing regulated by the TRAV, for example.



Die Zustimmung im Einzelfall muss bei der zuständigen Baubehörde beantragt werden, wenn keine anderen Regeln oder Zulassungen vorliegen. Die Zustimmung im Einzelfall gilt nur für das jeweilige Bauvorhaben. Hierbei können Statiken und/oder Bauteilversuche und/oder Resttragfähigkeitsversuche notwendig werden.

An application for individual approval (ZIE) must be submitted to the relevant building authorities in the absence of any other regulations or approvals. The individual approval in each case only applies to that particular building project. Statics and or component testing and or residual load-bearing capacity tests may be required for this.

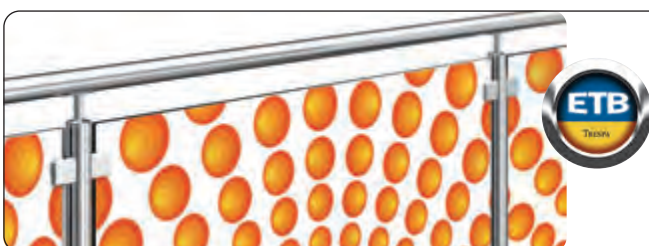

Die ETB Richtlinie (eingeführte technische Baubestimmung) für „Bauteile die gegen Absturz sichern“, ist für alle absturzsichernden Brüstungen anzuwenden, bei denen kein Glas zum Einsatz kommt, wie z. B. TRESPA®-Platten oder Seile.

The ETB (technical regulations introduced for "components that protect against falling") guideline applies to all safety balustrades where no glass infills are used, such as TRESPA® panels or cables.

Planungsablauf und zeitlicher Aufwand | planning process and time required

- Kundennahe und persönliche Planungshilfe | close customer relationship and personal planning assistance



KURZ | IN BRIEF

Als einziges Unternehmen kann Pauli + Sohn Allgemeine bauaufsichtliche Zulassungen in allen relevanten Bereichen des konstruktiven Glasbaus vorweisen.

Pauli + Sohn is the only company to have national technical approvals in all construction-related areas of glazing

Die Anwendbarkeit der Regelungen (z. B. TRAV) bzw. AbZ oder AbP hat einen großen Einfluss auf den Planungsablauf und die Planungssicherheit. So können Sie bei Anwendung mit einer AbZ oder TRAV sofort Beschläge und Glas bestellen. Bei einer Sonderlösung mit der ZiE können für die einzelnen Planungsschritte mindestens einige Wochen bis zu mehreren Monaten Zeit und Zusatzkosten erforderlich werden. Bei nicht wesentlichen Abweichungen zur AbZ oder zu einer technischen Regel kann häufig unbürokratisch und schnell eine Lösung gefunden werden. Kontaktieren Sie uns!

The applicability of the regulations e.g. (TRAV) and AbZ or AbP has a significant influence on the planning and safety process. When building according to an AbZ or TRAV, you can order fittings and glass immediately. Custom solutions with individual approval (ZiE) and their individual planning steps can take anything from several weeks up to several months and there may be additional costs. In certain circumstances where there are insignificant deviations from the AbZ or a technical regulation,, unbureaucratic solutions can often be found quickly. Contact us!

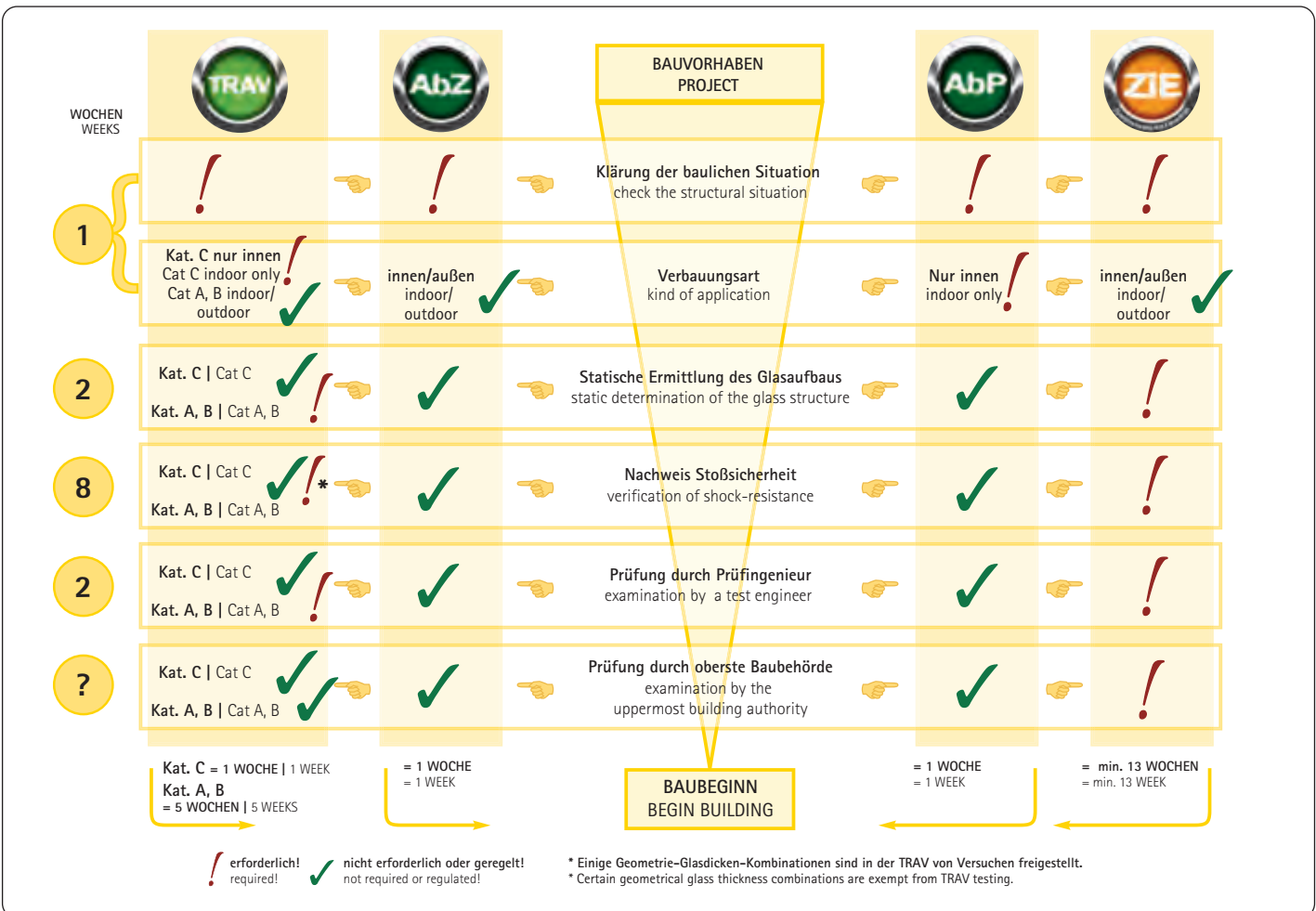

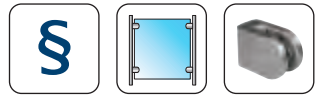

Richtig planen | plan correctly

■ Allgemein | general information



Füllung
infill



Holm
rail



Pfosten
post

1.

Auswahl Pfosten/Handlauf, Befestigungssystem und Füllung
post handrail, fixture system and infill selection

2.

Grundlagen Lasten und Systeme
basic loads and systems

3.

Nachweis Pfosten/Handlauf
-> siehe Seite 222

Bei der Montage von Befestigungssystem und Füllung an anderen Pfosten ist der Nachweis gesondert zu erbringen.

post/handrail verification
-> see page 222

If mounting fixture systems or infills to other posts, separate verification is required.

4.

Nachweis Befestigungssystem und Füllung (Stoß und Statik)
fixture system and infill verification (impact and statics)

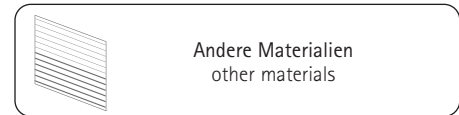
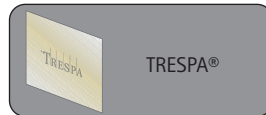

Seite | page 223

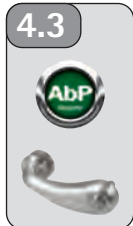

Seite | page 234

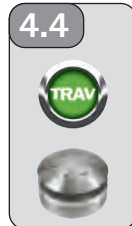

Seite | page 236



Seite | page 232

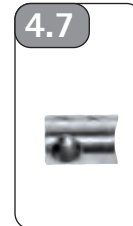

Seite | page 244



Seite | page 244



Seite | page 245



Seite | page 242



Seite | page 236



Seite | page 223



Seite | page 234

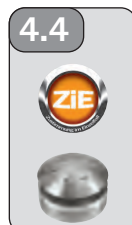

Seite | page 236



Seite | page 232

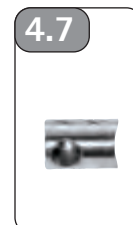

Seite | page 244

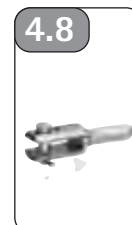

Seite | page 244



Seite | page 245



Seite | page 242



Seite | page 236

Nachweis Brüstung | balustrade verification

2.

■ Grundlagen für die Berechnung von Belastungen | basics for the computation of stress

Für den schnellen und einfachen Nachweis Ihrer Brüstung sind vorab einige Grundlagen – wie auf dieser Seite dargestellt – erforderlich. Als Belastung wirken Holmlast und Windlast. Aus der Montagesituation ergeben sich unterschiedliche Höhen der Pfosten des jeweiligen Anwendungsfalls (z. B. einzelnes Feld, Ecksituation), dieses ist ebenfalls Grundlage für den Nachweis.

This page shows some of the basics required in advance in order to verify your balustrade quickly and simply. The total load consists of wind and rail loads. The installation site determines the different post heights (e.g., single fields, corners). This is also the basis for the verification.

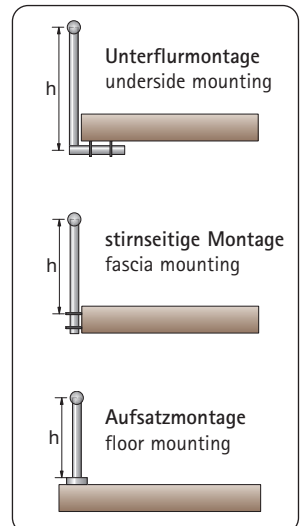
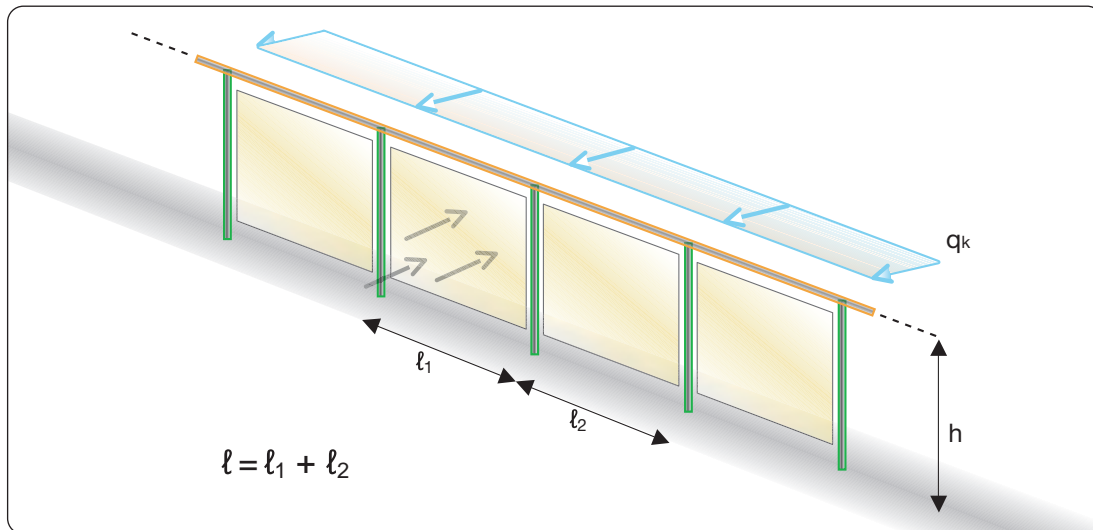

■ Mögliche Anwendungsfälle | possible applications

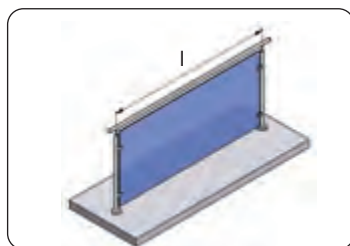

Einzelnes Geländerfeld
individual single railings

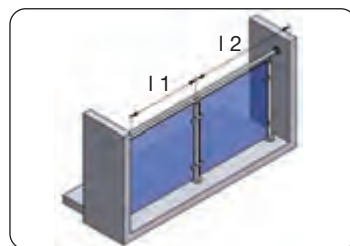

Geländer, gerade und zwischen Wänden
straight railings between walls

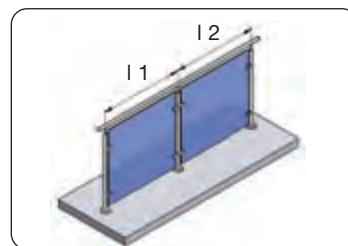

Geländer, gerade und freistehend
straight and free-standing railings

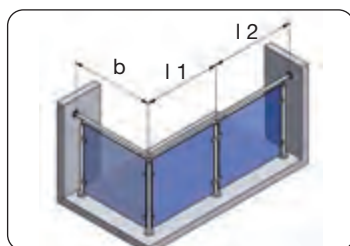

Abgewinkeltes Eckfeld
angled corners

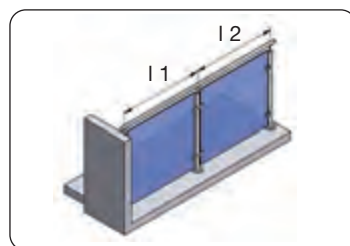

Endfeld ohne Befestigungen an der Wand
end area without wall mounting

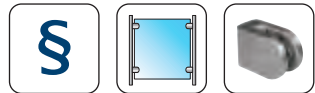

2. ←

Belastungen | loads

SERVICE

Schicken Sie uns die ausgefüllte Checkliste (Seite 230-231) und Sie erhalten von uns den Bemessungswert der veränderlichen Einwirkungen.

- Werte der horizontalen Nutzlast/Holmlast (Auszug aus der DIN 1055-3 3-2006)
values of the horizontal usage/rail load (extract from DIN 1055-3 3-2006)

Bei Brüstungen müssen gemäß DIN 1055-3 verschiedene Lasten berücksichtigt werden. Zum einen sind horizontale Nutzlasten von Personen auf Brüstungen und Geländer zu berücksichtigen. Die Größe der Holmlast q_k (siehe Tabelle unten) ist abhängig von der Nutzung. So ist die Holmlast natürlich unterschiedlich groß bei z.B. Brüstungen in einem Wohnhaus oder in einem Konzertsaal.

Different loads have to be considered according to DIN 1055 when using balustrades. On the one hand, there are the horizontal loads on balustrades and railings from people. The value of the rail load q_k (see table below) depends on usage. Therefore, the rail load in a private home is obviously different to that in a concert hall.

| Werte der Holmlast q_k | Kategorie nach DIN 1055-3, Tabelle 1 | Nutzung | Beispiele |
|--------------------------|--|---|--|
| 0,5 kN/m | A, B1 ohne nennenswerten Publikumsverkehr, T1, Z | A1> Spitzboden A2> Wohn- und Aufenthaltsräume B1> Büroflächen, Arbeitsflächen, Flure T1> Treppen und Treppenpodeste Z> Zugänge, Balkone. | A1> Für Wohnzwecke nicht geeigneter, aber zugänglicher Dachraum bis 1,80 m lichter Höhe. A2> Räume mit ausreichender Querverteilung der Lasten. Räume und Flure in Wohngebäuden, Bettenräume in Krankenhäusern, Hotelzimmer einschl. zugehöriger Küchen und Bäder. B1> Flure in Bürogebäuden, Büroflächen, Arztpraxen, Stationsräume, Aufenthaltsräume einschl. der Flure, Kleinviehställe. T1> Treppen und Treppenpodeste der Kategorie A und B1 ohne nennenswerten Publikumsverkehr. Z> Dachterrassen, Laubengänge, Loggien usw., Balkone, Ausstiegspodeste. |
| 1,0 kN/m | B1 mit nennenswertem Publikumsverkehr, B2, B3, C1 bis C4, E1 und E2, Z | B1-B3> Büroflächen, Arbeitsflächen, Flure C1-C4> Räume, Versammlungsräume und Flächen, die der Ansammlung von Personen dienen können (mit Ausnahme der in A, B, D, E festgelegten Kategorien.) E1-E2> Fabriken und Werkstätten, Ställe, Lagerräume und Zugänge, Flächen mit erheblicher Menschenansammlung Z> Zugänge, Balkone T2> Treppen und Treppenpodeste | B1> Flure in Bürogebäuden, Büroflächen, Arztpraxen, Stationsräume, Aufenthaltsräume einschl. der Flure, Kleinviehställe. B2> Flure in Krankenhäusern, Hotels, Altenheimen, Internaten usw.; Küchen u. Behandlungsräume einschl. Operationsräumen ohne schweres Gerät. B3> wie B2, jedoch mit schwerem Gerät. C1> Flächen mit Tischen; z. B. Schulräume, Cafés, Restaurants, Speisesäle, Empfangsräume. C2> Flächen mit fester Bestuhlung; z. B. Flächen in Küchen, Theatern oder Kinos, Kongresssäle, Hörsäle, Versammlungsräume, Wartesäle. C3> Frei begehbare Flächen; z. B. Museumsflächen, Ausstellungsflächen usw. und Eingangsbereiche in öffentlichen Gebäuden und Hotels, nicht befahrbare Hofkellerdecken. C4> Sport- und Spielflächen; z. B. Tanzsäle, Sporthallen, Gymnastik- und Kraftsporträume, Bühnen. E1> Flächen in Fabriken und Werkstätten mit leichtem Betrieb und Flächen in Großviehställen. E2> Lagerflächen, einschl. Bibliotheken. T2> Treppen und Treppenpodeste der Kategorie B1 mit erheblichem Publikumsverkehr. B2 bis E sowie alle Treppen, die als Fluchtweg dienen. Z> Dachterrassen, Laubengänge, Loggien usw., Balkone, Ausstiegspodeste. |
| 2,0 kN/m | C5, E3, T3 | C5> Räume, Versammlungsräume und Flächen, die der Ansammlung von Personen dienen können (mit Ausnahme der in A, B, D, E festgelegten Kategorien). E3> Fabriken und Werkstätten, Ställe, Lagerräume und Zugänge, Flächen mit erheblicher Menschenansammlung T3> Treppen und Treppenpodeste | C5> Flächen für große Menschenansammlungen; z. B. in Gebäuden wie Konzertsäle, Terrassen und Eingangsbereiche sowie Tribünen mit fester Bestuhlung. E3> Flächen in Fabriken und Werkstätten mit mittlerem oder schwerem Betrieb, Flächen mit regelmäßiger Nutzung durch erhebliche Menschenansammlungen, Tribünen ohne feste Bestuhlung. T3> Zugänge und Treppen von Tribünen ohne feste Sitzplätze, die als Fluchtweg dienen. |



- Stoß | impact

Bei absturzsichernden Verglasungen ist zusätzlich eine Belastung durch Anprall zu berücksichtigen. Der Nachweis kann durch Einhalten der Bedingungen der TRAV (d. h. Tabellen oder Pendelschlagversuche) erfolgen. Eine AbZ ist gleichwertig mit der TRAV, die Nachweise gegen Stoß sind hier bereits erbracht.

Impact forces must also be considered for safety barrier glazing. Verification can be ensured by abiding to the terms of the TRAV (i.e. tables or pendulum impact tests). An AbZ is equivalent to the TRAV, verification against impact is already provided here.



Belastungen | loads

2. →

Windlast | wind load

Neben Schnee werden Gebäude und Bauteile durch Wind belastet. Die Windlast gehört – wie der Schnee – zu den klimatisch bedingten, veränderlichen Einwirkungen. Auch hier hängt es natürlich davon ab, wo die Brüstung montiert wird: Die Windlast auf einer Nordseeinsel wird größer sein, als mitten in der Großstadt.

Besides snow, buildings and construction elements are also subject to wind loads. The wind load – as with snow – is a climatic factor with variable effects. Of course, a lot depends on, where the balustrade built: the wind load on an island in the North Sea will be greater than in a large city.

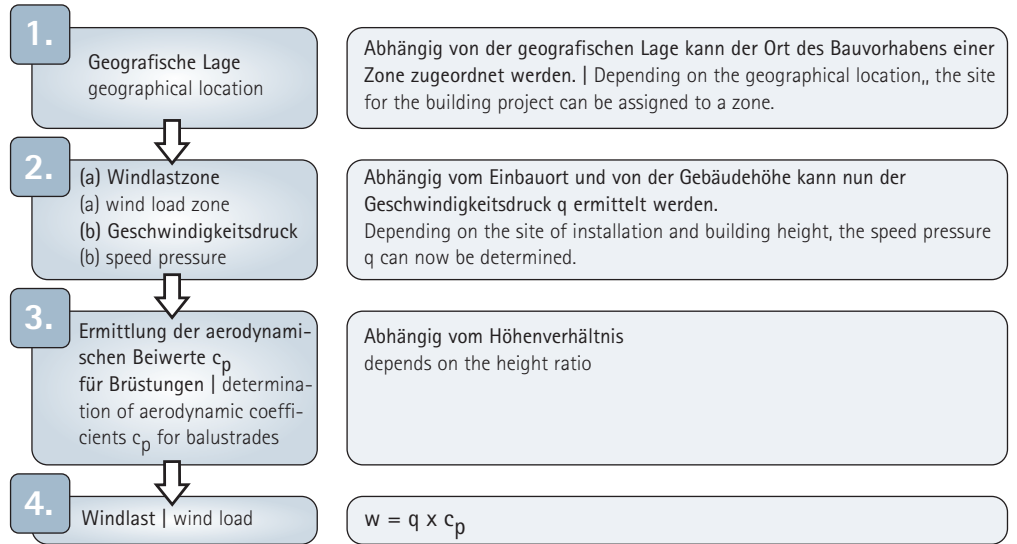
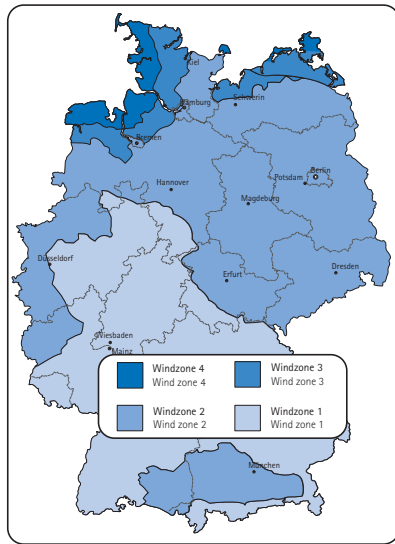

Vereinfachte Geschwindigkeitsdrücke für Bauwerke bis 25 m Höhe
simplified speed pressures for buildings of up to 25 m in height

| Windzone wind zone | Geschwindigkeitsdruck in q in kN/m ² bei einer Gebäudehöhe q in den Grenzen von speed pressure in q in kN/m ² at a building height q to a limit of | | |
|--|---|-------------------|-------------------|
| | h < 10 m | 10 m < h ≤ 18 m | 18 m < h ≤ 25 m |
| 1 Binnenland inland | 0,50 | 0,65 | 0,75 |
| 2 Binnenland inland Küste und Inseln der Ostsee Baltic Sea coast and islands | 0,65 0,85 | 0,80 1,00 | 0,90 1,10 |
| 3 Binnenland inland Küste und Inseln der Ostsee Baltic Sea coast and islands | 0,80 1,05 | 0,95 1,20 | 1,10 1,30 |
| 4 Binnenland inland Küste der Ost- und Nordsee Baltic and North Sea coasts Inseln der Ostsee Baltic Sea islands Inseln der Nordsee North Sea islands | 0,95 1,25 1,40 | 1,15 1,40 - | 1,30 1,55 - |

INFO

Ein statischer Nachweis oder eine Lastermittlung darf nur durch einen anerkannten Statiker erbracht werden. Daher lassen Sie bitte die ermittelten Lastwerte überprüfen!

Static verification or load determination may only be performed by recognised structural engineers. Therefore, please have the load values determined checked!

Aerodynamische Beiwerte c_p für Brüstungen | aerodynamic coefficients c_p for balustrades

| Bereich zone | A | B | C | D | |
|---|---------------|-----------|-----------|-----------|-----|
| gerade Wand straight wall | $l/h \leq 3$ | 2,3 | 1,4 | 1,2 | 1,2 |
| | $l/h = 5$ | 2,9 | 1,8 | 1,4 | 1,2 |
| | $l/h \geq 10$ | 3,4 | 2,1 | 1,7 | 1,2 |
| abgewinkelte Wand \geq mit Schenkellänge $\geq h$ angled wall \geq with side length $\geq h$ | $\pm 2,1$ | $\pm 1,8$ | $\pm 1,4$ | $\pm 1,2$ | |

Auszug aus der DIN 1055-4 | extract from DIN 1055-4

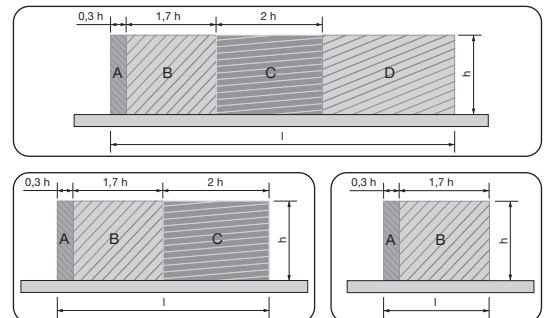

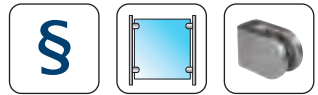

3.

Nachweis Pfosten/Handlauf | posts handrail verification

- Werte der maximalen Pfostenabstände | maximum post spacing values

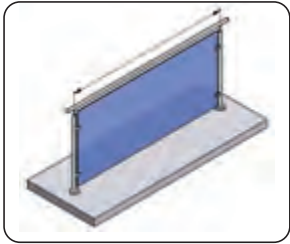

Bodenanker Standard Ø 38 mm
floor anchor standard Ø 38 mm



Art. Nr. | item no.:
10500700 ⁽¹⁾

Bodenanker verstärkt Ø 38 mm
floor anchor reinforced Ø 38 mm



Art. Nr. | item no.:
10502000 ⁽²⁾
10502100 ⁽³⁾

Bodenanker verstärkt Ø 44 mm
floor anchor reinforced Ø 44 mm



Art. Nr. | item no.:
10502200 ⁽⁴⁾
10502300 ⁽⁵⁾

Pfostenabstände, einzelnes Geländerfeld | post spacings, individual railing

| Pfostenhöhe post height | Querschnitt d x t cross section d x t | horizontale Nutzlast horizontal payload qk | | |
|---|--|--|----------|----------|
| | | 0,5 kN/m | 1,0 kN/m | 2,0 kN/m |
| 1000 mm, Art. Nr. item no.: 10502000 ⁽²⁾ | 42,4 x 2 mm | 3522 mm | 1761 mm | 880 mm |
| 1000 mm, Art. Nr. item no.: 10502100 ⁽³⁾ | | 2721 mm | 1360 mm | 680 mm |
| 1000 mm, Art. Nr. item no.: 10500700 ⁽¹⁾ | | 2041 mm | 1020 mm | 510 mm |
| 1100 mm, Art. Nr. item no.: 10502000 ⁽²⁾ | | 3522 mm | 1761 mm | 880 mm |
| 1100 mm, Art. Nr. item no.: 10502100 ⁽³⁾ | | 2401 mm | 1200 mm | 600 mm |
| 1100 mm, Art. Nr. item no.: 10500700 ⁽¹⁾ | 1855 mm | 928 mm | 464 mm | |
| 1200 mm, Art. Nr. item no.: 10500700 ⁽¹⁾ | 1701 mm | 850 mm | 425 mm | |
| 1000 mm, Art. Nr. item no.: 10502200 ⁽⁴⁾ | 48,3 x 2 mm | 4736 mm | 2368 mm | 1184 mm |
| 1000 mm, Art. Nr. item no.: 10502300 ⁽⁵⁾ | | 3593 mm | 1797 mm | 898 mm |
| 1100 mm, Art. Nr. item no.: 10502200 ⁽⁴⁾ | | 4736 mm | 2368 mm | 1184 mm |
| 1100 mm, Art. Nr. item no.: 10502300 ⁽⁵⁾ | | 3170 mm | 1585 mm | 793 mm |

- Multiplikator für Tabellenwerte bei anderen Anwendungen
multiplier for table values in other applications

Geländer, gerade und zwischen Wänden | straight railings between walls

für Innenpfosten | for inner posts
Faktor | factor 0,5

Geländer, gerade und freistehend straight and free-standing railings

für Innenpfosten | for inner posts
Faktor | factor 0,5

Endfeld ohne Befestigungen an der Wand end area without wall mounting

für Randpfosten | for outside posts
Faktor | factor 1,0

Abgewinkeltes Eckfeld angled corners

für Eckpfosten | for corner posts
Faktor | factor 1,0

Bei anderen Einbausituationen sind die Tabellenwerte mit dem jeweiligen Faktor zu multiplizieren.

For other mounting conditions, the table values should be multiplied by the respective factor.

- Beispiel: durchlaufendes Geländer, Holmlast 0,5 kN/m
example: continuous railing, rail load 0.5 kN/m

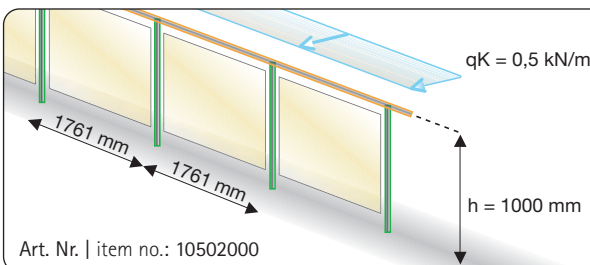

h = 1000 mm
Pfosten | post = 42,4 x 2 mm
maximal möglicher Pfostenabstand
maximum possible distance between posts
3522 mm x 0,5 = 1761 mm

Nachweis Füllung noch nicht beinhaltet!
Confirmation for infill is not yet included!



Nachweis der Klemmen und Füllung AbZ Z-70.2-28 clamps infill verification according to AbZ Z-70.2-28

Einfache Anwendung der AbZ | simple application of the AbZ

Die auf den folgenden Seiten bestimmten Klemmen sind nach AbZ zugelassen. Wie Sie die Tabellen der AbZ lesen können und die Auswahl der Klemmen richtig vornehmen, zeigen wir auf dieser Seite. Gerne stehen wir Ihnen bei der Auswahl zur Verfügung.

The following pages show the approved clamps according to the AbZ. We will show briefly on this page how to choose the correct clamps by reading the AbZ tables. We would be happy to assist you with your selection.

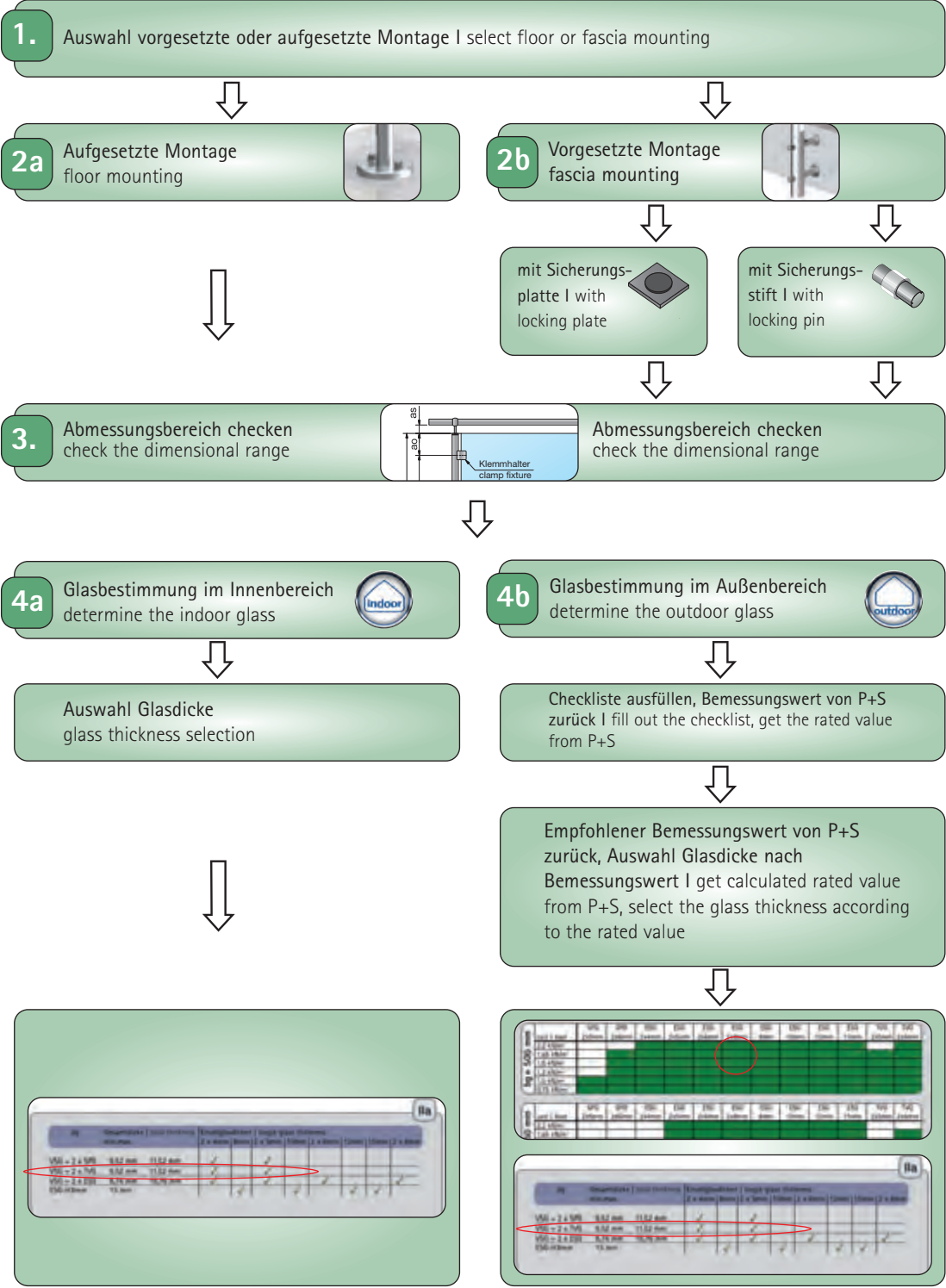

| AbZ | |
|---|---|
| Tragfähigkeit load-bearing capacity | Glasstatik vorhanden glass statics available ✓ |
| Resttragfähigkeit residual load-bearing capacity | Durch AbZ abgedeckt covered by AbZ ✓ |
| ZiE bei Baubehörde ZiE from building authority | Antrag nicht erforderlich application not required ✓ |
| Wir unterstützen Sie! We can support you! | |

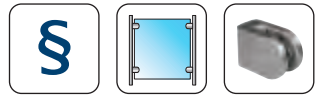

Nachweis der Klemmen und Füllung | clamp infill verification

- Klemmen nach AbZ Z-70.2-28 mit Glasfüllung | Clamps according to AbZ Z-70.2-28 with glass infills

Diese Doppelseite zeigt Ihnen die Abmessungen der Geländerfüllungen für die Klemmen ohne Sicherungsstift und ohne Sicherungsplatte.

These two pages show the dimensions of the railing infills for clamps without locking pins and without locking plates.

Vorgehensweise | procedure:

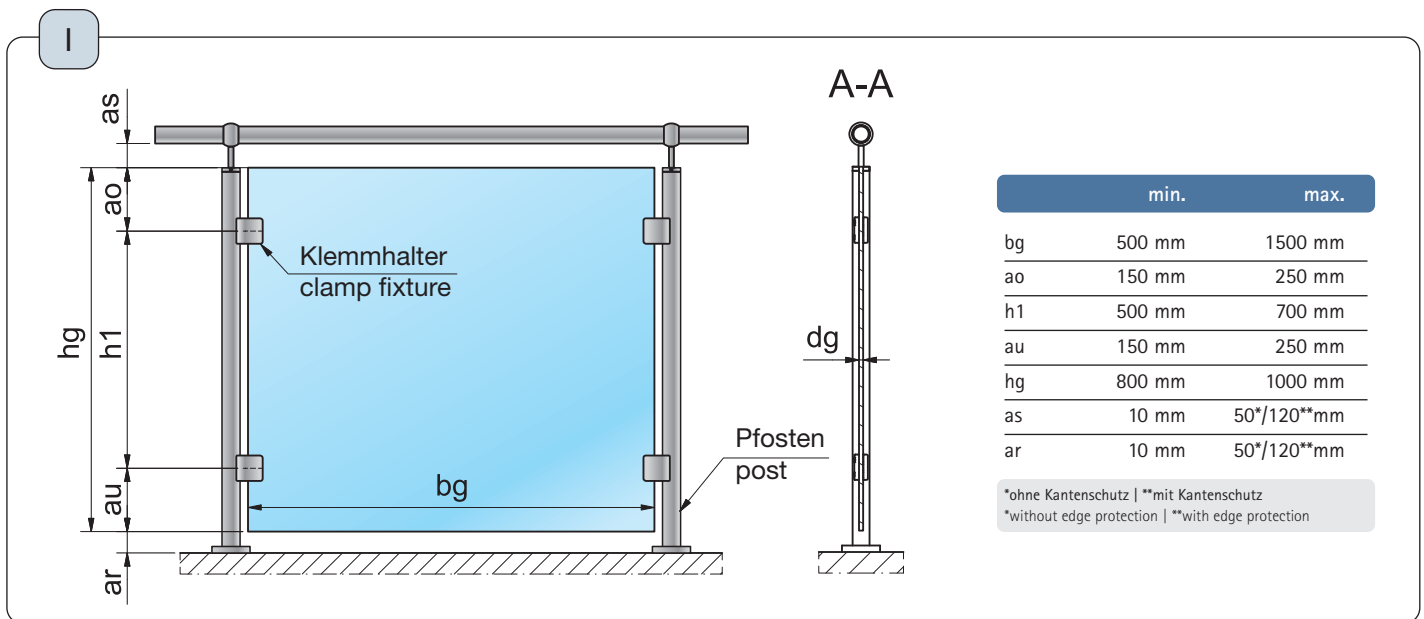
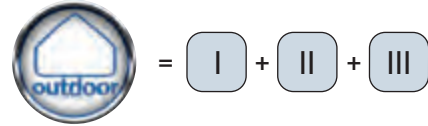
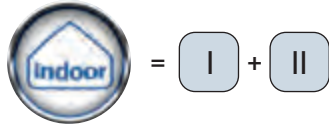

- Alle Klemmen mit der Verwendung nach AbZ ohne Sicherungsstift und Sicherungsplatte
all clamps according to the AbZ without locking pins or locking plates



Anwendung ohne Sicherungsstift und ohne Sicherungsplatte
application without locking pins and without locking plates

| Art. Nr. item no. | Art. Nr. item no. |
|---|---|
| 4800 4801 4802 | 4808 4809 4810 4811 4812 4842 4843 4852 4853 4854 9300 9301 9302 9303 9304 9305 9306 9307 9308 9309 |
| 4804 4805 4806 4807 9002 9006 | 4813 4814 4816 4817 4821 4827 9013 9014 9016 9017 9320 9321 9322 9323 9324 9325 9326 9327 9328 9329 |
| 4841 4845 4846 4847 4848 4859 9044 9045 9047 9048 9341 9343 9344 9347 9348 9349 | 11110 11112 11113 11117 11118 11119 |
| 4890 4891 4893 4894 4896 4897 9082 9086 | 9511 9512 9513 9521 9522 9523 9711 9712 9713 9721 9722 9723 |
| 9330 9331 9332 9333 9334 9335 9336 9337 9338 9339 | 4831 4832 4836 4837 |



Nachweis der Klemmen und Füllung | clamp infill verification

- Klemmen ohne Sicherungsstift + ohne Sicherungsplatte für den Innenbereich
clamps without locking pins and without locking plates for indoor use

II

| dg | Gesamtdicke total thickness | | Einzelglasdicken single glass thickness | | | | | | | | | |
|---------------|-------------------------------|----------|---|-----|---------|------|---------|------|------|---------|---|---|
| | min. | max. | 2 x 4mm | 8mm | 2 x 5mm | 10mm | 2 x 6mm | 12mm | 15mm | 2 x 8mm | | |
| VSG = 2 x SPG | 9,52 mm | 11,52 mm | ✓ | | ✓ | | | | | | | |
| VSG = 2 x TVG | 9,52 mm | 11,52 mm | ✓ | | ✓ | | | | | | | |
| VSG = 2 x ESG | 8,76 mm | 16,76 mm | ✓ | | ✓ | | | ✓ | | ✓ | ✓ | ✓ |
| ESG-H | 8 mm | 15 mm | | ✓ | | | ✓ | | ✓ | ✓ | | |

Glasdickenbestimmung
defining the
glass thickness

- Klemmen ohne Sicherungsstift + ohne Sicherungsplatte. Diese Tabelle ist zusätzlich für den Außenbereich anzuwenden (Windlast). | clamps without locking pins + without locking plates. This table is also applicable for outdoor use (wind load).

III

Mögliche Glasdicken für die Anwendungen im Außenbereich, abhängig von Windlast und Scheibenbreite (bg) ohne Sicherungsstift, ohne Sicherungsplatte (grüne Felder sind möglich)

possible glass thickness for outdoor applications, depending on the wind load and glass width (bg) without locking pins, without locking plates (green fields are possible)

| bg = 500 mm | Last load | SPG 2x5mm | SPG 2x6mm | ESG 2x4mm | ESG 2x5mm | ESG 2x6mm | ESG 2x8mm | ESG 8mm | ESG 10mm | ESG 12mm | ESG 15mm | TVG 2x5mm | TVG 2x6mm |
|------------------------|-----------------------|-----------|-----------|-----------|-----------|-----------|-----------|---------|----------|----------|----------|-----------|-----------|
| | 2,2 kN/m ² | | | | | | | | | | | | |
| 1,65 kN/m ² | | | | | | | | | | | | | |
| 1,6 kN/m ² | | | | | | | | | | | | | |
| 1,2 kN/m ² | | | | | | | | | | | | | |
| 1,0 kN/m ² | | | | | | | | | | | | | |
| 0,75 kN/m ² | | | | | | | | | | | | | |

| bg = 750 mm | Last load | SPG 2x5mm | SPG 2x6mm | ESG 2x4mm | ESG 2x5mm | ESG 2x6mm | ESG 2x8mm | ESG 8mm | ESG 10mm | ESG 12mm | ESG 15mm | TVG 2x5mm | TVG 2x6mm |
|------------------------|-----------------------|-----------|-----------|-----------|-----------|-----------|-----------|---------|----------|----------|----------|-----------|-----------|
| | 2,2 kN/m ² | | | | | | | | | | | | |
| 1,65 kN/m ² | | | | | | | | | | | | | |
| 1,6 kN/m ² | | | | | | | | | | | | | |
| 1,2 kN/m ² | | | | | | | | | | | | | |
| 1,0 kN/m ² | | | | | | | | | | | | | |
| 0,75 kN/m ² | | | | | | | | | | | | | |

| bg = 1000 mm | Last load | SPG 2x5mm | SPG 2x6mm | ESG 2x4mm | ESG 2x5mm | ESG 2x6mm | ESG 2x8mm | ESG 8mm | ESG 10mm | ESG 12mm | ESG 15mm | TVG 2x5mm | TVG 2x6mm |
|------------------------|-----------------------|-----------|-----------|-----------|-----------|-----------|-----------|---------|----------|----------|----------|-----------|-----------|
| | 2,2 kN/m ² | | | | | | | | | | | | |
| 1,65 kN/m ² | | | | | | | | | | | | | |
| 1,6 kN/m ² | | | | | | | | | | | | | |
| 1,2 kN/m ² | | | | | | | | | | | | | |
| 1,0 kN/m ² | | | | | | | | | | | | | |
| 0,75 kN/m ² | | | | | | | | | | | | | |

| bg = 1250 mm | Last load | SPG 2x5mm | SPG 2x6mm | ESG 2x4mm | ESG 2x5mm | ESG 2x6mm | ESG 2x8mm | ESG 8mm | ESG 10mm | ESG 12mm | ESG 15mm | TVG 2x5mm | TVG 2x6mm |
|------------------------|-----------------------|-----------|-----------|-----------|-----------|-----------|-----------|---------|----------|----------|----------|-----------|-----------|
| | 2,2 kN/m ² | | | | | | | | | | | | |
| 1,65 kN/m ² | | | | | | | | | | | | | |
| 1,6 kN/m ² | | | | | | | | | | | | | |
| 1,2 kN/m ² | | | | | | | | | | | | | |
| 1,0 kN/m ² | | | | | | | | | | | | | |
| 0,75 kN/m ² | | | | | | | | | | | | | |

| bg = 1500 mm | Last load | SPG 2x5mm | SPG 2x6mm | ESG 2x4mm | ESG 2x5mm | ESG 2x6mm | ESG 2x8mm | ESG 8mm | ESG 10mm | ESG 12mm | ESG 15mm | TVG 2x5mm | TVG 2x6mm |
|------------------------|-----------------------|-----------|-----------|-----------|-----------|-----------|-----------|---------|----------|----------|----------|-----------|-----------|
| | 2,2 kN/m ² | | | | | | | | | | | | |
| 1,65 kN/m ² | | | | | | | | | | | | | |
| 1,6 kN/m ² | | | | | | | | | | | | | |
| 1,2 kN/m ² | | | | | | | | | | | | | |
| 1,0 kN/m ² | | | | | | | | | | | | | |
| 0,75 kN/m ² | | | | | | | | | | | | | |

Glasdickenbestimmung
defining the
glass thickness



Nachweis der Klemmen und Füllung | clamp infill verification

- Klemmen nach AbZ Z-70.2-28 mit Glasfüllung | Clamps according to AbZ Z-70.2-28 with glass infills

Diese Doppelseite zeigt Ihnen die Abmessungen der Geländerfüllungen für die Klemmen mit Sicherungsstift.

These two pages show the dimensions of railing infills for clamps with locking pins.

Vorgehensweise | procedure:

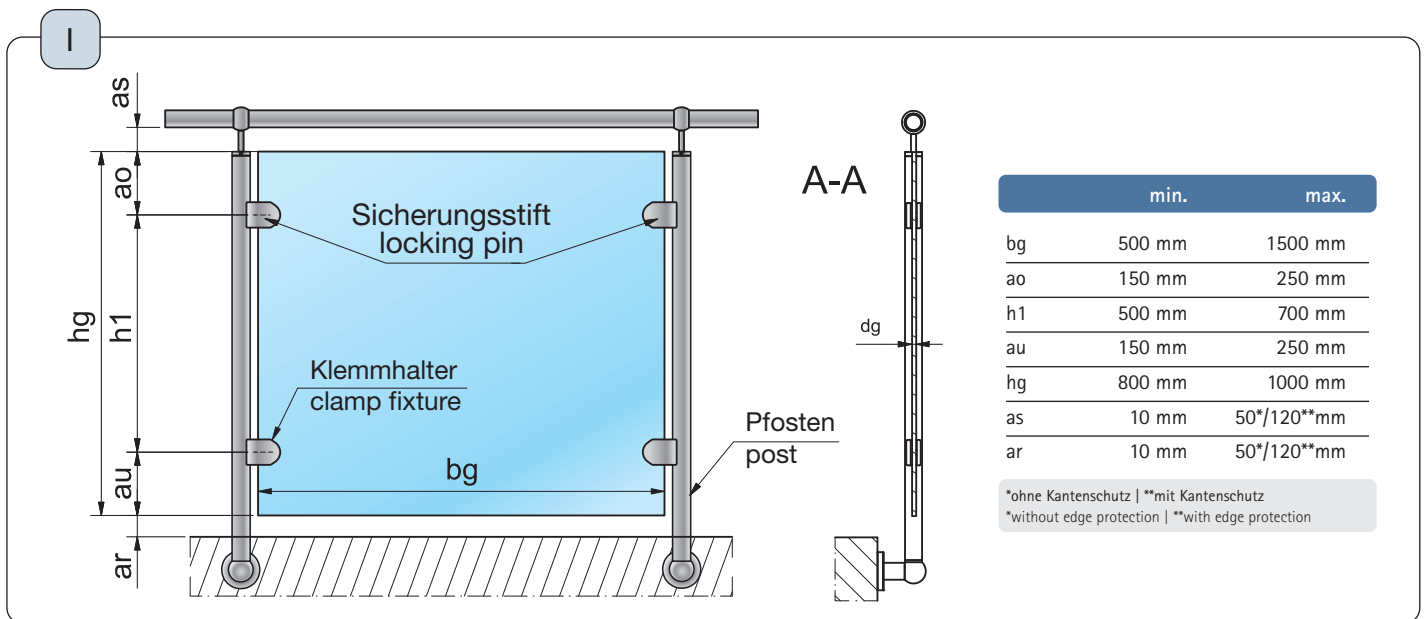
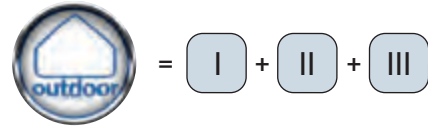
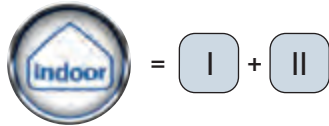

- Alle Klemmen mit der Verwendung nach AbZ mit Sicherungsstift
all clamps according to the AbZ with locking pins



Anwendung mit Sicherungsstift z. B. 17010600 | application with locking pin e. g. 17010600

Sicherungsstift bei oberen und unteren Klemmbefestigungen erforderlich | locking pin is required with upper and lower clamp fixtures

Art. Nr. | item no.



4821 4827 9013 9014 9016 9017



9320 9321 9324 9325 9328 9329

Das heißt vier Bohrungen im Glas, die Lage der Bohrung richtet sich nach der verwendeten Klemme. Ab Seite 18.

This means four holes are required in the glass, the location of the hole depends on the used clamp. From page 18 onwards.

Sicherungsstift nur bei oberen Klemmbefestigungen erforderlich | locking pin is required in the case of upper clamp fixtures only

Art. Nr. | item no.



9511 9512 9513 9711 9712 9713



9521 9522 9523 9721 9722 9723

Das heißt zwei Bohrungen im Glas, die Lage der Bohrung richtet sich nach der verwendeten Klemme. Ab Seite 29.

This means two holes are required in the glass, the location of the hole depends on the clamp used. From page 29 onwards.



Nachweis der Klemmen und Füllung | clamp infill verification

- Klemmen mit Sicherungstift für den Innen- und Außenbereich
clamps with locking pins for indoor and outdoor use

II

| dg | Gesamtdicke total thickness | | Einzelglasdicken single glass thickness | | | | | |
|---------------|-------------------------------|----------|---|-----|---------|------|---------|------|
| | min. | max. | 2 x 4mm | 8mm | 2 x 5mm | 10mm | 2 x 6mm | 12mm |
| VSG = 2 x SPG | 9,52 mm | 11,52 mm | ✓ | | ✓ | | | |
| VSG = 2 x TVG | 9,52 mm | 11,52 mm | ✓ | | ✓ | | | |
| VSG = 2 x ESG | 8,76 mm | 16,76 mm | ✓ | | ✓ | | ✓ | |
| ESG-H | 8 mm | 15 mm | | ✓ | | ✓ | ✓ | ✓ |



Glasdickenbestimmung
defining the
glass thickness

- Klemmen mit Sicherungstift. Diese Tabelle ist zusätzlich für den Außenbereich anzuwenden (Windlast). | clamps with locking pins. This table is also applicable for outdoor use (wind load).

III

Mögliche Glasdicken für die Anwendungen im Außenbereich, abhängig von Windlast und Scheibenbreite (bg) mit Sicherungstift (grüne Felder sind möglich)

possible glass thickness for outdoor applications, depending on the wind load and glass width (bg) with locking pins (green fields are possible)

| Last load | ESG | ESG | ESG | ESG | ESG | ESG |
|------------------------|-------|-------|-------|-----|------|------|
| | 2x4mm | 2x5mm | 2x6mm | 8mm | 10mm | 12mm |
| 2,2 kN/m ² | | | | | | |
| 1,65 kN/m ² | | | | | | |
| 1,6 kN/m ² | | | | | | |
| 1,2 kN/m ² | | | | | | |
| 1,0 kN/m ² | | | | | | |
| 0,75 kN/m ² | | | | | | |

| Last load | ESG | ESG | ESG | ESG | ESG | ESG |
|------------------------|-------|-------|-------|-----|------|------|
| | 2x4mm | 2x5mm | 2x6mm | 8mm | 10mm | 12mm |
| 2,2 kN/m ² | | | | | | |
| 1,65 kN/m ² | | | | | | |
| 1,6 kN/m ² | | | | | | |
| 1,2 kN/m ² | | | | | | |
| 1,0 kN/m ² | | | | | | |
| 0,75 kN/m ² | | | | | | |

| Last load | ESG | ESG | ESG | ESG | ESG | ESG |
|------------------------|-------|-------|-------|-----|------|------|
| | 2x4mm | 2x5mm | 2x6mm | 8mm | 10mm | 12mm |
| 2,2 kN/m ² | | | | | | |
| 1,65 kN/m ² | | | | | | |
| 1,6 kN/m ² | | | | | | |
| 1,2 kN/m ² | | | | | | |
| 1,0 kN/m ² | | | | | | |
| 0,75 kN/m ² | | | | | | |

| Last load | ESG | ESG | ESG | ESG | ESG | ESG |
|------------------------|-------|-------|-------|-----|------|------|
| | 2x4mm | 2x5mm | 2x6mm | 8mm | 10mm | 12mm |
| 2,2 kN/m ² | | | | | | |
| 1,65 kN/m ² | | | | | | |
| 1,6 kN/m ² | | | | | | |
| 1,2 kN/m ² | | | | | | |
| 1,0 kN/m ² | | | | | | |
| 0,75 kN/m ² | | | | | | |

| Last load | ESG | ESG | ESG | ESG | ESG | ESG |
|------------------------|-------|-------|-------|-----|------|------|
| | 2x4mm | 2x5mm | 2x6mm | 8mm | 10mm | 12mm |
| 2,2 kN/m ² | | | | | | |
| 1,65 kN/m ² | | | | | | |
| 1,6 kN/m ² | | | | | | |
| 1,2 kN/m ² | | | | | | |
| 1,0 kN/m ² | | | | | | |
| 0,75 kN/m ² | | | | | | |



Glasdickenbestimmung
defining the
glass thickness

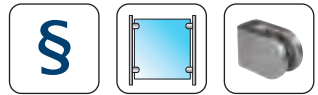

Nachweis der Klemmen und Füllung | clamp infill verification

- Klemmen nach AbZ Z-70.2-28 mit Glasfüllung | clamps according to AbZ Z-70.2-28 with glass infills

Diese Doppelseite zeigt Ihnen die Abmessungen der Geländerfüllungen für die Klemmen mit Sicherungsplatte.

These two pages show the dimensions of railing infills for using clamps with locking plates.



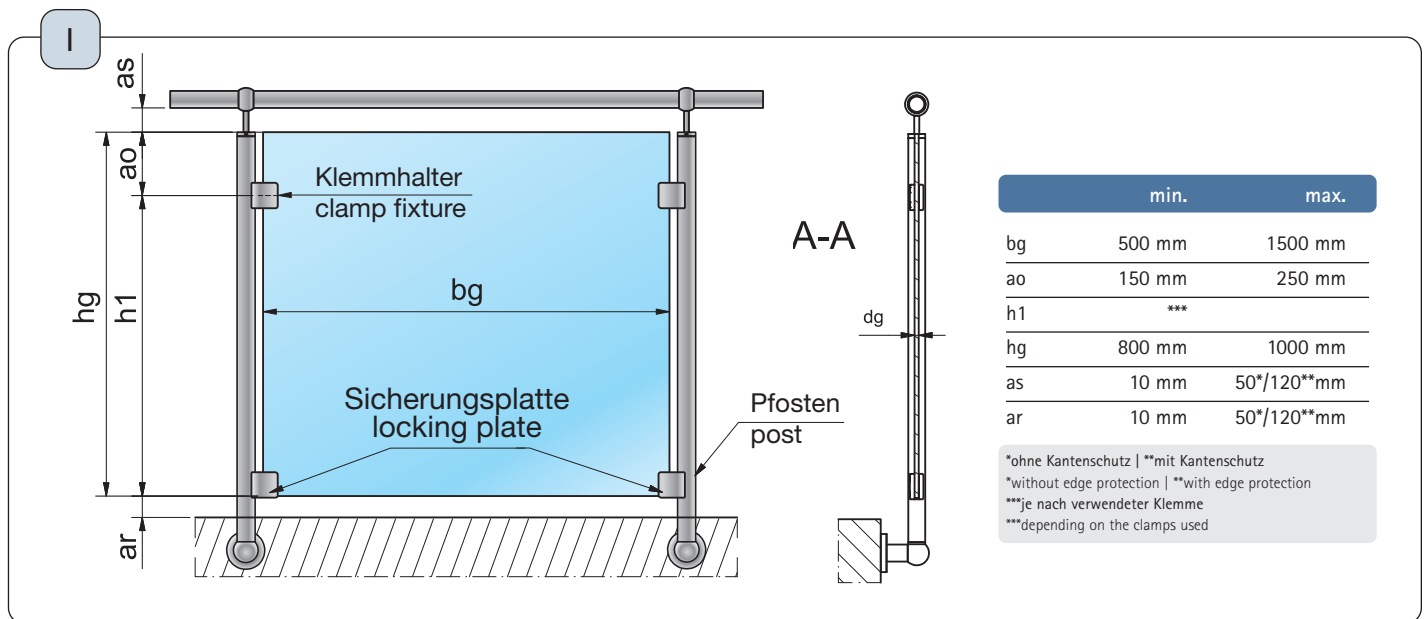
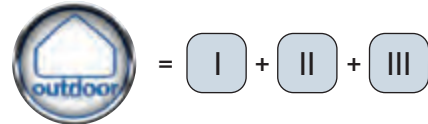
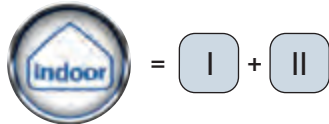

Vorgehensweise | procedure:



- Alle Klemmen mit der Verwendung nach AbZ mit Sicherungsplatte
all clamps according to the AbZ with locking plates



Anwendung mit Sicherungsplatte
z. B. 17011000 | application with
locking plate e. g. 17011000

| Art. Nr. item no. | Art. Nr. item no. |
|---|--|
|  4800 4801 4802 |  4890 4891 4893 4894 4896 4897 9082 9086 |
|  4804 4805 4806 4807 9002 9006 |  9330 9331 9332 9333 9334 9335 9336 9337 9338 9339 |
|  4841 4845 4846 4847 4848 4859 9044 9045 9047 9048 9341 9343 9344 9347 9348 9349 | |



Nachweis der Klemmen und Füllung | clamp infill verification

- Klemmen mit Sicherungsplatte für den Innenbereich
Clamps with locking plates for indoor use

II

| dg | Gesamtdicke total thickness | | Einzelglasdicken single glass thickness | | | | | | | |
|---------------|-------------------------------|----------|---|-----|---------|------|---------|------|------|---------|
| | min. | max. | 2 x 4mm | 8mm | 2 x 5mm | 10mm | 2 x 6mm | 12mm | 15mm | 2 x 8mm |
| VSG = 2 x ESG | 8,76 mm | 16,76 mm | ✓ | | ✓ | | ✓ | | ✓ | |
| ESG-H | 8 mm | 15 mm | | ✓ | | ✓ | | ✓ | ✓ | ✓ |



Glasdickenbestimmung
defining the
glass thickness

- Klemmen mit Sicherungsplatte. Diese Tabelle ist zusätzlich für den Außenbereich anzuwenden (Windlast). | clamps with locking plates. This table is also applicable for outdoor use (wind load).

III

Mögliche Glasdicken für die Anwendungen im Außenbereich, abhängig von Windlast und Scheibenbreite (bg) mit Sicherungsplatte (grüne Felder sind möglich)

possible glass thickness for outdoor applications, depending on the wind load and glass width (bg) with locking plates (green fields are possible)

| bg | Last load | ESG | ESG | ESG | ESG | ESG | ESG | ESG | ESG |
|---------|------------------------|-------|-------|-------|-------|-----|------|------|------|
| | | 2x4mm | 2x5mm | 2x6mm | 2x8mm | 8mm | 10mm | 12mm | 15mm |
| 500 mm | 2,2 kN/m ² | | | | | | | | |
| | 1,65 kN/m ² | | | | | | | | |
| | 1,6 kN/m ² | | | | | | | | |
| | 1,2 kN/m ² | | | | | | | | |
| | 1,0 kN/m ² | | | | | | | | |
| | 0,75 kN/m ² | | | | | | | | |
| 750 mm | 2,2 kN/m ² | | | | | | | | |
| | 1,65 kN/m ² | | | | | | | | |
| | 1,6 kN/m ² | | | | | | | | |
| | 1,2 kN/m ² | | | | | | | | |
| | 1,0 kN/m ² | | | | | | | | |
| | 0,75 kN/m ² | | | | | | | | |
| 1000 mm | 2,2 kN/m ² | | | | | | | | |
| | 1,65 kN/m ² | | | | | | | | |
| | 1,6 kN/m ² | | | | | | | | |
| | 1,2 kN/m ² | | | | | | | | |
| | 1,0 kN/m ² | | | | | | | | |
| | 0,75 kN/m ² | | | | | | | | |
| 1250 mm | 2,2 kN/m ² | | | | | | | | |
| | 1,65 kN/m ² | | | | | | | | |
| | 1,6 kN/m ² | | | | | | | | |
| | 1,2 kN/m ² | | | | | | | | |
| | 1,0 kN/m ² | | | | | | | | |
| | 0,75 kN/m ² | | | | | | | | |
| 1500 mm | 2,2 kN/m ² | | | | | | | | |
| | 1,65 kN/m ² | | | | | | | | |
| | 1,6 kN/m ² | | | | | | | | |
| | 1,2 kN/m ² | | | | | | | | |
| | 1,0 kN/m ² | | | | | | | | |
| | 0,75 kN/m ² | | | | | | | | |



Glasdickenbestimmung
defining the
glass thickness

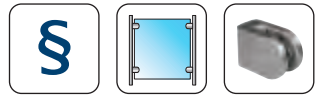

Richtig planen | Plan correctly

- Checkliste Klembefestigungen für die Verbauung im Außenbereich AbZ Z-70.2-28



1. Brüstungstyp und Abmessungen: Bitte gewünschten Montagetyp auswählen

Aufsatzmontage:

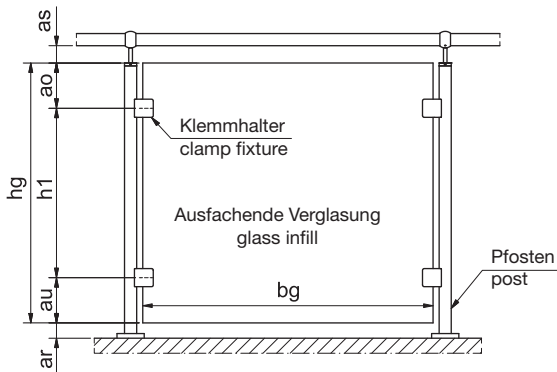

Vorsatzmontage mit Sicherungsstift:

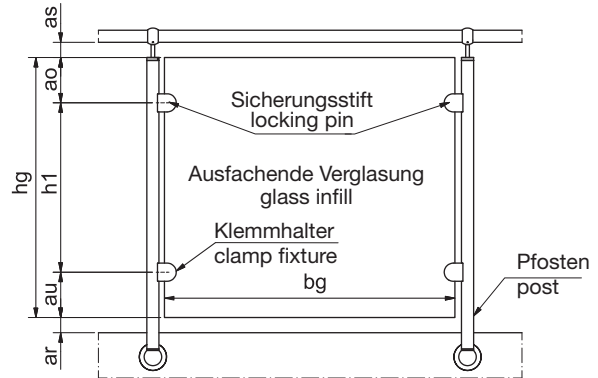

Vorsatzmontage mit Sicherungsplatte:

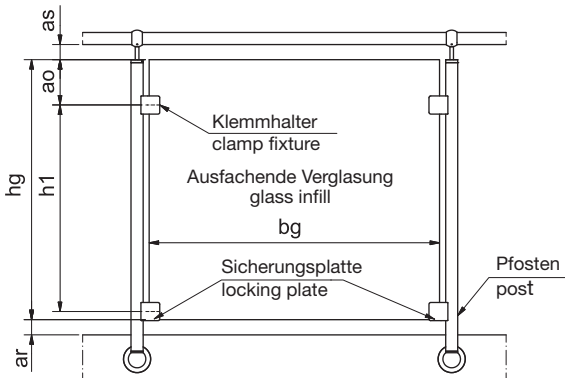

Abmessungen:

bg = _____
 h1 = _____
 hg = _____
 ao = _____

Bei Modellscheiben bitte Zeichnung beilegen!

Gewünschte Glasart:

ESG-H, t= 8mm 10mm 12mm 15mm
 VSG aus 2 x ESG, t= 4mm 5mm 6mm 8mm 0,76 mm
 VSG aus 2 x TVG, t= 4mm 5mm 6mm 1,52 mm
 VSG aus 2 x SPG, t= 4mm 5mm 6mm

PVB-Folie:

SERVICE

Füllen Sie diese Checkliste einfach aus und faxen Sie uns diese zu! Danach bekommen Sie alle Angaben zu Ihrer Brüstung.

2. Beschläge

Welche Beschläge sollen verwendet werden für

- Klemmen: Art. Nr. oder Bezeichnung _____, Anzahl _____
- Pfosten und Handlauf: Art. Nr. oder Bezeichnung _____, Anzahl _____



Richtig planen | Plan correctly

- Checkliste Klemmbefestigungen für die Verbauung im Außenbereich AbZ Z-70.2-28



3. Belastung (charakteristischer Wert der Einwirkung)

Es liegen keine Angaben zu Last oder Gebäudegeometrie vor.
Wir möchten darauf hinweisen, dass infolge der neuen Lastannahmennorm DIN 1055 die anzusetzenden Lasten sehr variieren. Daher ist ohne entsprechende Angaben keine

Glasdickenermittlung möglich und somit auch keine Planungssicherheit vorhanden. Wir können daher nur Glasdickenermittlungen für ausgewählte Laststufen durchführen.

Charakteristischer Wert der Einwirkungen (i. d. R. Windlast)

q = _____ kN/m²

Die Ermittlung des charakteristischen Wertes der Einwirkungen soll durch DM erfolgen.
Durch die neue Lastnorm DIN 1055 ist die Ermittlung der Last komplizierter geworden. Diese Lastnorm ist für alle AbZs und alle technischen Regeln (d. h. z. B. auch TRLV) anzuwenden. Deutsche Metall unterstützt Sie bei der Ermittlung der anzusetzenden Lasten.

Wir möchten Sie darauf hinweisen, dass ein statischer Nachweis oder auch eine Lastermittlung nur durch einen anerkannten Statiker erbracht werden kann. Daher ist der durch DM ermittelte Wert nur als Anhaltswert zu verstehen und nicht verbindlich!

Für die Ermittlung des Bemessungswertes der veränderlichen Einwirkung sind folgende Angaben zwingend erforderlich:

Einbauort: _____ **PLZ:** _____

Binnenland Küste der Nord- und Ostsee und Inseln der Ostsee Inseln der Nordsee

Einbauhöhe über Oberkante Gelände h = _____ Gebäudehöhe H = _____

Länge der Brüstung l = _____ Breite der Brüstung b = _____

Brüstungstyp:

Gerade und freistehend: Gerade u. zwischen Wänden: Abgewinkeltes Eckfeld: Einzelnes Geländerfeld: Endfeld ohne Wandbefestigung:

Für die Ermittlung des Bemessungswertes der veränderlichen Einwirkung sind folgende Angaben für uns hilfreich, aber nicht erforderlich:

Windlastzone = _____

Charakteristischer Wert der Holmlast q_k = _____ kN/m



Eingeführte technische Baubestimmungen | implemented technical building regulations

■ Allgemeines | general information

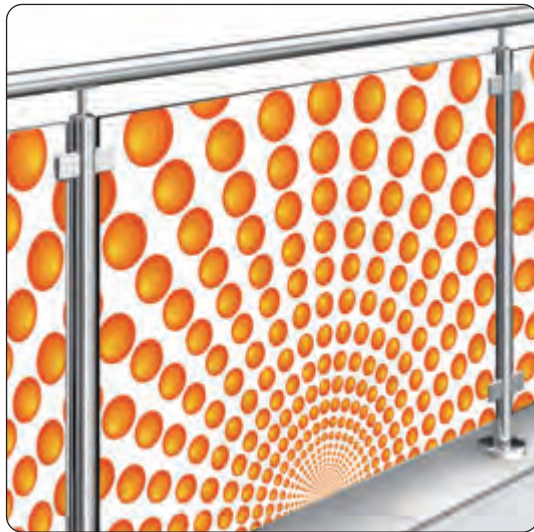

ETB - Eingeführte technische Baubestimmungen

Um sicher zu stellen, dass bauliche Anlagen nicht die öffentliche Sicherheit oder Ordnung gefährden, existieren unter anderem technische Baubestimmungen. Sie sind in der Bauregelliste aufgeführt. Die ETB-Richtlinien „Bauteile, die gegen Absturz sichern“ (1995-06) regeln Absturzsicherungen - Füllungen aus Glas sind ausgenommen. Für einige unserer Produkte gelten die ETB-Richtlinien.

ETB - implemented technical building regulations

In order to ensure that structural works do not endanger public safety, technical building regulations have been drawn up, amongst other things. They are specified in the building regulation code. The ETB guidelines for "components that protect against falling" (1995-06) regulate safety barriers - glass infills are exempted. Certain P+S products are covered by the ETB guidelines.

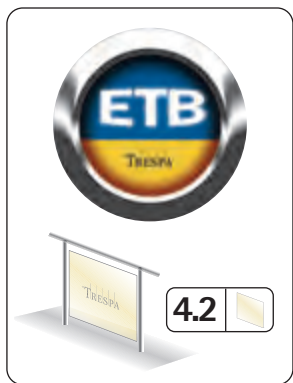

■ ETB mit TRESPA® Füllungen | ETB with TRESPA® panel infills

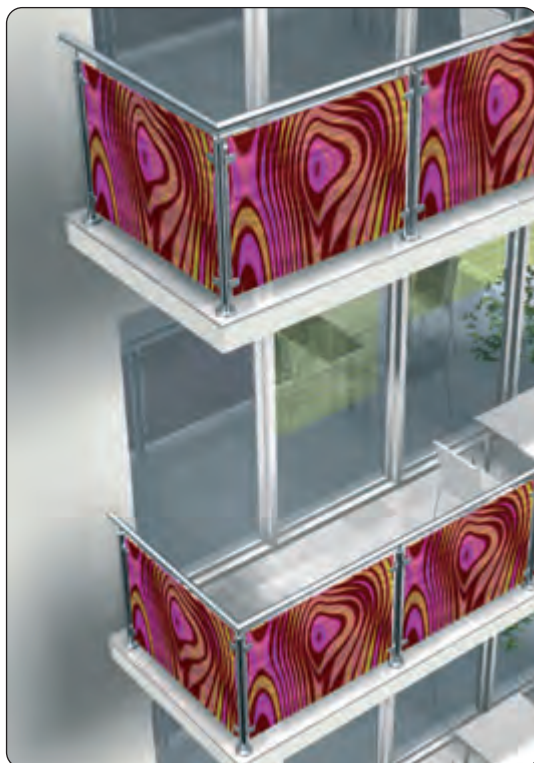

Pauli + Sohn hat in Zusammenarbeit mit der Fa. TRESPA® den Nachweis nach ETB-Richtlinie, „Bauteile, die gegen Absturz sichern“ von P+S Klemmsystemen in Kombination mit TRESPA®-Schichtstoffplatten erbracht.

Damit erschließt sich für den Verbauer von Balkon- und Treppengeländern eine neue Anwendungsmöglichkeit von geprüften Systemen.

Pauli + Sohn, in cooperation with the company TRESPA®, has provided certification according to ETB guidelines for "components that protect against falling" using P+S clamp system and TRESPA® laminated panels.

This opens up new ways for builders of balconies and stair railings to use tested systems.

Prüfzeugnisse: auf Wunsch
lieferbar
test certificates: available
on request





Einsatzgebiet TRESPA® | TRESPA® applications

■ Material, Füllungen | material infills

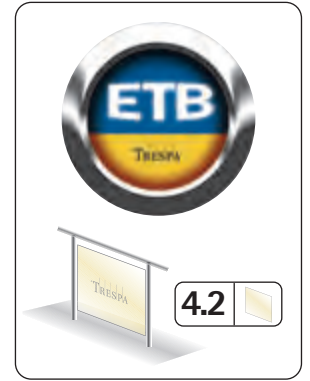
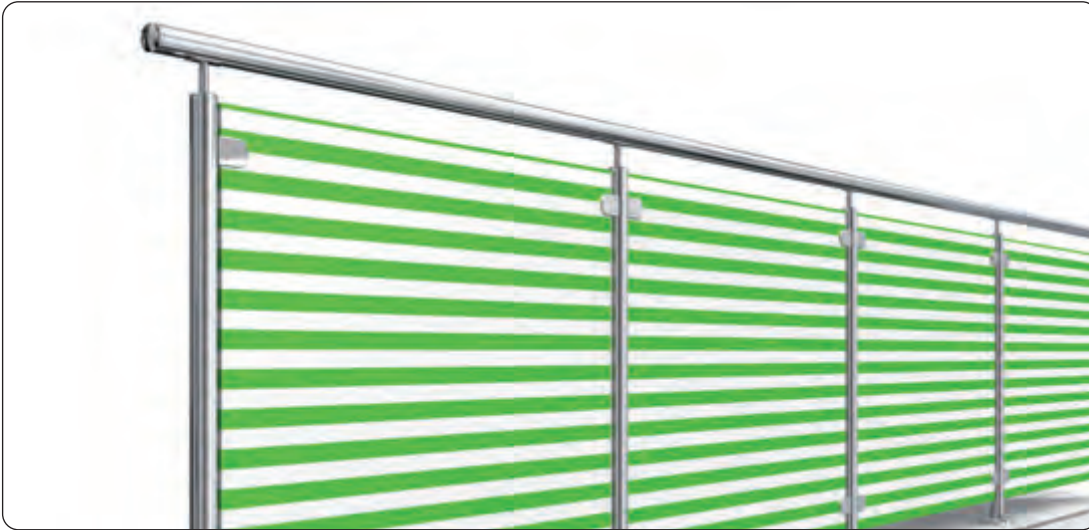

Die Anforderungen der Klemmen (siehe Tabelle) genügen der Richtlinie „Bauteile, die gegen Absturz sichern“ hinsichtlich ihrer Widerstandsenergie bei Beanspruchung durch weichen Stoß und harten Stoß (3.2.2 und 3.2.3). Die geprüften Befestigungsmittel haben bei einer Prüfkraft größer 2,8 kN keine Schädigungen gezeigt, obwohl die Klemmbefestigungen bereits durch die Testreihen vorbelastet waren. Alle Anforderungen wurden somit erfüllt.

The clamp requirements (see table) fulfil the "components which protect against falling" guideline, with regard their to resistance in the case of hard or soft impacts (3.2.2 and 3.2.3). The tested fastening components have shown no damage when subjected to a testing load of 2,8 kN, although the clamp fixtures were prestressed in the test series. All requirements have thereby been fulfilled.

| Art. Nr. item no. | Material | Abmessungen dimensions | | | | *bestanden mit passed with |
|---------------------|----------|--------------------------|---------|---------|--|------------------------------|
| 4804 | ZN | 8 mm | 1000 mm | 750 mm | | 4 Klemmen clamps |
| 4806 | ZN | 8 mm | 1000 mm | 750 mm | | 4 Klemmen clamps |
| 4805 | ZN | 10 mm | 1500 mm | 1100 mm | | 6 Klemmen clamps |
| 4807 | ZN | 10 mm | 1500 mm | 1100 mm | | 6 Klemmen clamps |
| 9333 | VA | 10 mm | 1500 mm | 1100 mm | | 6 Klemmen clamps |
| 9337 | VA | 10 mm | 1500 mm | 1100 mm | | 6 Klemmen clamps |
| 11112 | ZN | 8 mm | 1006 mm | 756 mm | | 4 Klemmen clamps |
| 11117-R15 | ZN | 8 mm | 1006 mm | 756 mm | | 4 Klemmen clamps |
| 11117-R20 | ZN | 8 mm | 1006 mm | 756 mm | | 4 Klemmen clamps |
| 9343 | VA | 8 mm | 1002 mm | 752 mm | | 4 Klemmen clamps |
| 9347 | VA | 8 mm | 1002 mm | 752 mm | | 4 Klemmen clamps |
| 9344 | VA | 10 mm | 1502 mm | 1102 mm | | 6 Klemmen clamps |
| 9348 | VA | 10 mm | 1502 mm | 1102 mm | | 6 Klemmen clamps |
| 4808 | ZN | 8 mm | 994 mm | 744 mm | | 4 Klemmen clamps |
| 4842 | ZN | 8 mm | 994 mm | 744 mm | | 4 Klemmen clamps |
| 9303 | VA | 10 mm | 1494 mm | 1094 mm | | 6 Klemmen clamps |
| 9307 | VA | 10 mm | 1494 mm | 1094 mm | | 6 Klemmen clamps |

| ETB TRESPA | |
|--|--|
| Tragfähigkeit Füllung load-bearing capacity | Nur im Außenbereich erforderlich only necessary in outdoor applications |
| Resttragfähigkeit residual load- bearing capacity | Versuchsbericht nicht erforderlich test report not necessary |
| ZiE bei Baube- hörde ZiE from building authority | Antrag nicht erforder- lich application not required |
| Wir unterstützen Sie! We can support you! | |

*Ergebnis der ETB-Prüfung (E min. = 125Nm) bestanden mit | result of the ETB testing (E min. = 125Nm) passed with



Banano mit Prüfzeugnis | Banano with test certificate

■ Anwendung und Richtlinien | application and regulation



Der Verbinder Banano weicht in einigen Punkten von den Randbedingungen der TRAV Kategorie C ab. Daher ist für dieses Bauprodukt ein Allgemeines bauaufsichtliches Prüfzeugnis erforderlich. Das AbP ist gleichwertig mit einer AbZ und in ganz Deutschland gültig.

The connector Banano differs in some respects from the framework conditions in the TRAV category C. Therefore, a general test certificate (AbP) from building authorities is required for this construction product. This is equivalent to an AbZ and is valid throughout Germany.

| | |
|---|--|
| | |
| Tragfähigkeit load-bearing capacity | Glasstatik im Innenbereich nicht erforderlich glass statics not required indoors |
| Resttragfähigkeit residual load-bearing capacity | Versuchsbericht nicht erforderlich test report not necessary |
| ZiE bei Baubehörde ZiE from building authority | Im Innenbereich Antrag nicht erforderlich application not required for indoor use |
| Wir unterstützen Sie! We can support you! | |

■ Der einfache Weg mit dem AbP | The easy way with an AbP

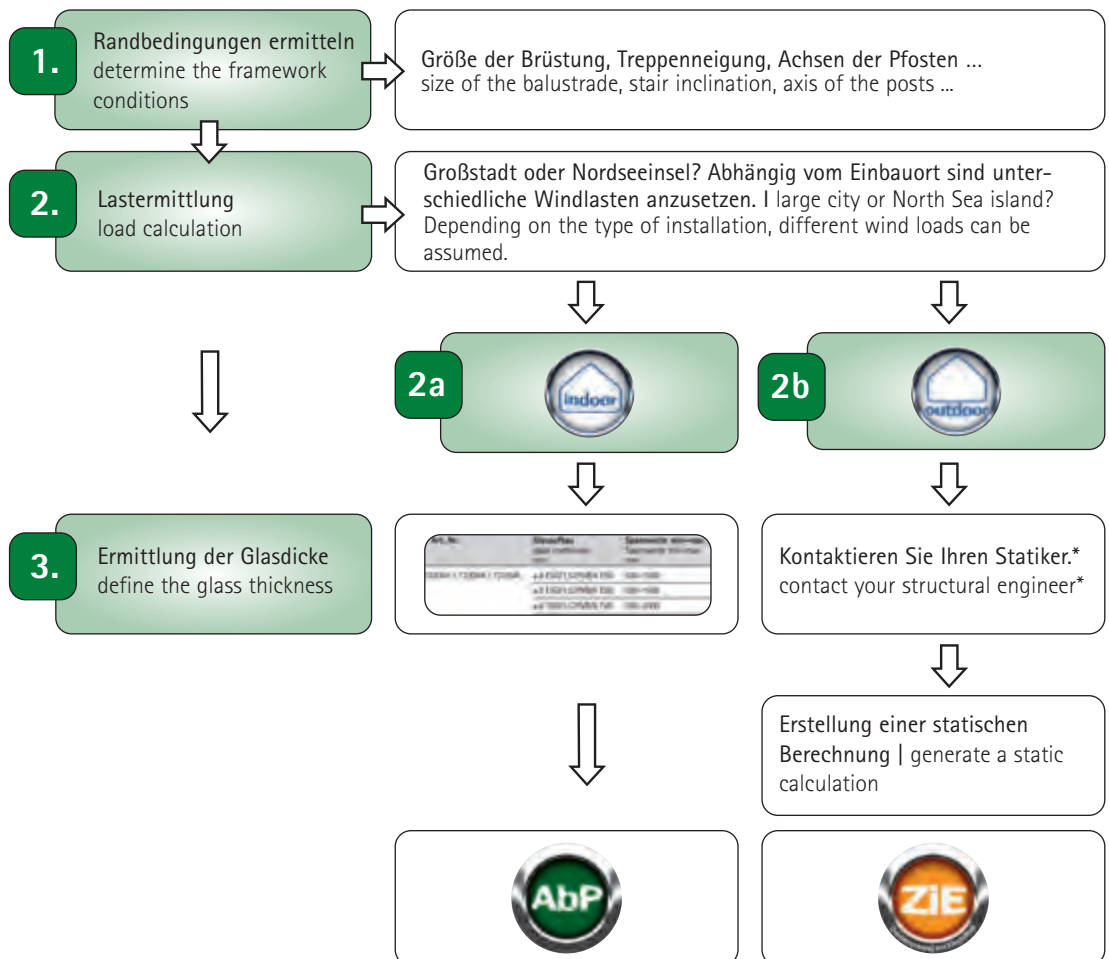

SERVICE

*Wir können Ihnen gerne ein Ingenieurbüro vermitteln

*Of course we can give you the contact data of our recommended engineers office.



Banano mit Prüfzeugnis | Banano with test certificate

■ Anwendung und Richtlinien | application and regulation

Bevor unsere Halter zum Verkauf angeboten werden, erproben wir sie auf Herz und Nieren. So werden die Halter von unabhängigen Instituten auf die verschiedenen Beanspruchungen praxisnah geprüft. Die Nachweise werden entsprechend den Normen geführt.

Before our fixtures go on sale, we test them from A to Z. Our fixtures are tested for different practical demands by independent institutes. Verifications are provided according to the standards.



Der Nachweis der Tragfähigkeit unter stoßartigen Einwirkungen wurde sowohl von der Vorderseite als auch von der Rückseite erbracht. Es gelten die Anforderungen an die Versuche gemäß TRAV. Der Nachweis der Tragfähigkeit unter stoßartigen Einwirkungen der Verglasung und ihrer unmittelbaren Befestigung (Halterung, Verschraubung) ist für den Anwendungsbereich mit dem AbP erbracht.

The verification of the load-bearing capacity under impact has been provided from the front the rear. The requirements of the TRAV in respect of testing have to be met. The load-bearing capacity of the glazing and its immediate fixing (fixtures, screw connections) under impact has been verified for the application area covered by the general certificate from building authorities (AbP).

Für das VSG gelten die Bestimmungen der Bauregelliste A Teil1 lfd. Nr. 11.8. Die VSG-Scheiben müssen, je nach Scheibenabmessungen, aus zwei Scheiben ESG der in der Tabelle angegebenen Dicken bestehen. Die Scheiben können eine Rechteck- oder Parallelogrammform analog der TRAV haben.

For LSG, the regulations of building regulation code A part 1 sequential number 11.8 have to be applied. Depending on the dimensions of the panels, the LSG panels have to be made up of two tempered safety glass panels with the thicknesses stated in the table. The panels can be rectangular or parallelogram in shape, similar to the TRAV.

Banano hat ein allgemeines bauaufsichtliches Prüfzeugnis, somit sind keine weiteren Versuche und keine Zustimmung im Einzelfall erforderlich!

Banano has a general test certificate from building authorities, so no additional tests or individual approvals are required!

| Art. Nr. item no. | Glasaufbau glass structure mm | Spannweite min. - max. min. - max. span width mm | Höhe min. - max. min. - max. height mm |
|--------------------------|-------------------------------------|--|--|
| 7220VA 7230VA 7235VA | ≥ 4 ESG/1,52 PVB/4 ESG | 500 - 1500 | 800 - 1000 |
| | ≥ 5 ESG/1,52 PVB/5 ESG | 500 - 1500 | 800 - 1000 |
| | ≥ 6 TVG/1,52 PVB/6 TVG | 500 - 2000 | 800 - 1000 |

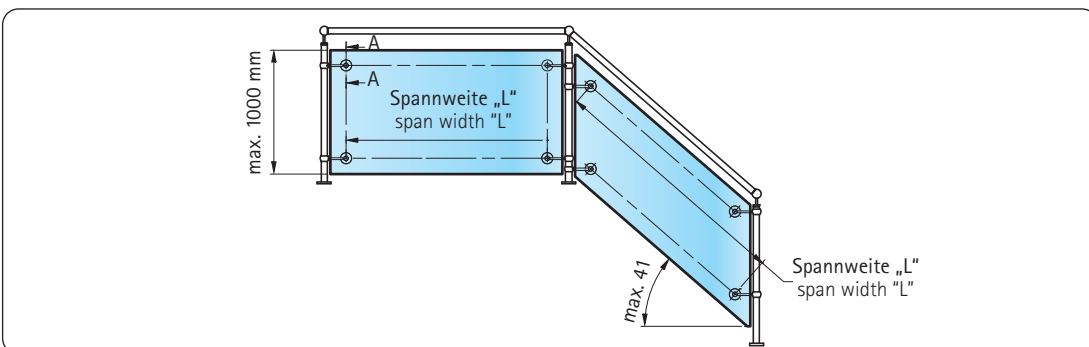



TRAV (Technische Regeln für die Verwendung absturzsichernder Verglasungen)
TRAV (technical rules for safety balustrades)

Der einfache Weg mit TRAV | the easy way with TRAV

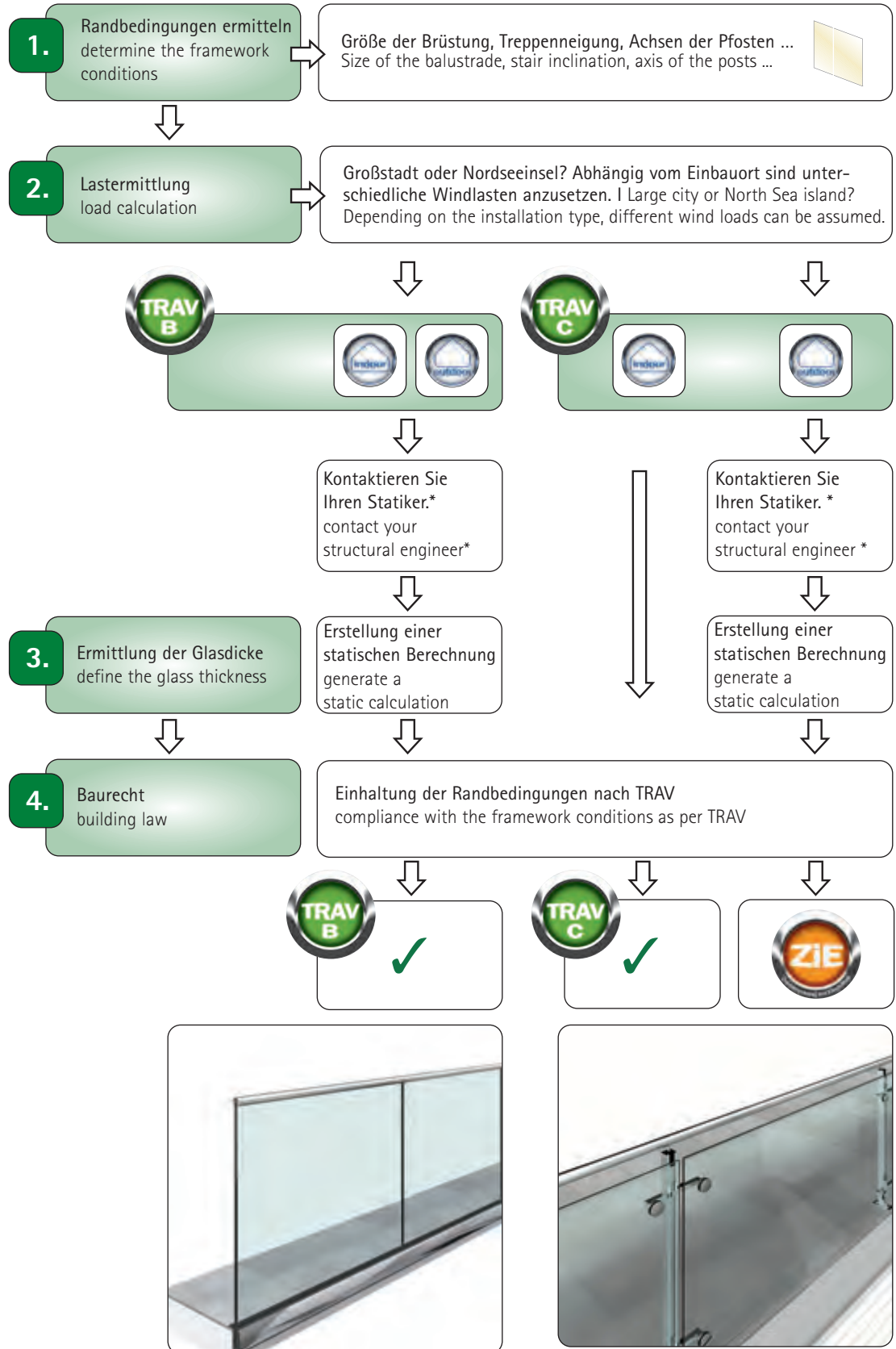

SERVICE
*Wir können Ihnen gerne ein Ingenieurbüro vermitteln
*Of course we can give you the contact data of our recommended engineers office.

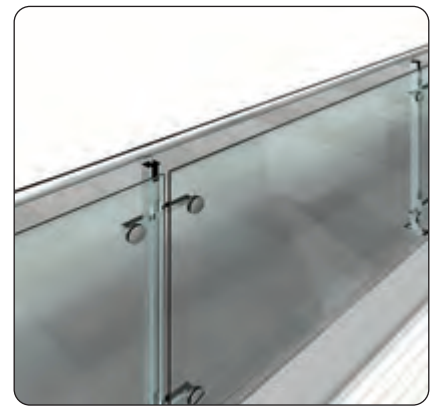



TRAV (Technische Regeln für die Verwendung absturzsichernder Verglasungen) TRAV (technical rules for safety balustrades)

TRAV

Geltungsbereich:

Die technischen Regeln gelten für die nachfolgend beschriebenen mechanisch gelagerten Verglasungen, wenn diese auch dazu dienen, Personen auf Verkehrsflächen gegen seitlichen Absturz zu sichern.

Geregelt werden:

- Vertikalverglasungen nach den TRLV, an die, wegen ihrer absturzsichernden Funktion, die zusätzlichen Anforderungen der TRAV gestellt werden;
- tragende Glasbrüstungen mit durchgehendem Handlauf;
- Geländerausfachungen aus Glas, die entweder Anforderungen nach TRLV und nach TRAV erfüllen müssen, oder Geländerausfachungen aus Glas, die ausschließlich Anforderungen nach TRAV erfüllen müssen, z. B. punktförmig gelagerte Geländerausfachungen in Innenräumen.

Kategorien nach TRAV | TRAV categories

Kategorie B: an ihrem unteren Rand in einer Klemmkonstruktion linienförmig gelagerte tragende Glasbrüstung, deren einzelne Scheiben durch einen aufgesteckten durchgehenden Handlauf verbunden sind. Neben dem Schutz der oberen Kante der Glasbrüstung, muss der Handlauf die sichere Abtragung der planmäßigen Horizontallasten in Holmhöhe (Holmlast) auch beim Ausfall eines Brüstungselements gewährleisten.

Kategorie C: absturzsichernde Verglasungen, die nicht zur Abtragung von Horizontallasten in Holmhöhe dienen und einer der folgenden Gruppen entsprechen:

- C1: an mindestens zwei gegenüberliegenden Seiten linienförmig und/oder punktförmig gelagerte Geländerausfachungen.
- C2: Unterhalb eines in Holmhöhe angeordneten, lastabtragenden Querriegels befindliche und an min. zwei gegenüberliegenden Seiten linienförmig gelagerte Vertikalverglasungen im Sinne der TRLV.
- C3: Verglasungen der Kategorie A mit vorgesetztem lastabtragendem Holm in baurechtlich erforderlicher Höhe.

Scope:

The technical rules apply mechanically installed glazing described below if it is also used to safeguard persons in circulation areas from sideward falls.

The regulations cover:

- vertical glazing according to the TRLV which must also comply with the requirements of the TRAV due to its function to protect against falling.
- load-bearing glass balustrades with continuous hand-rails and
- glass railing infills which must either meet the requirements of TRLV and the TRAV or glass railing infills which must only meet the requirements of the TRAV, e.g. pointed railing infills in indoor areas.

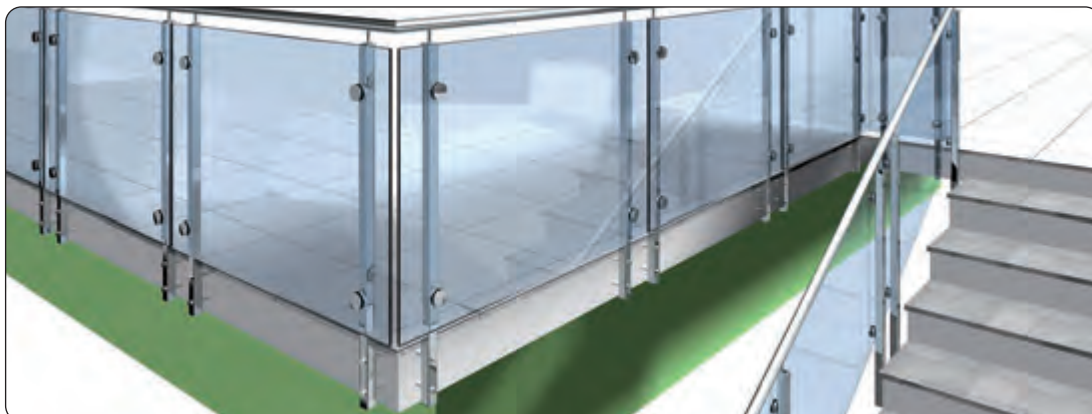

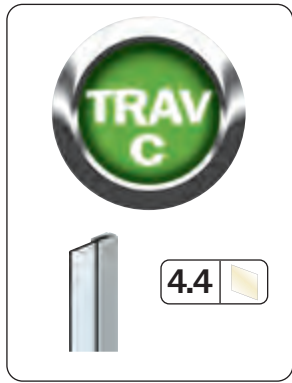

Brüstungsverglasung nach TRAV | balustrade glazing according to TRAV

- Linienförmige Lagerung nach TRAV | linear mounting according to TRAV



Klemmprofil | clamping profile
Art. Nr.: | item no. 198884__



Mehr technische Informationen auf Seite 521 | more technical information page 521

Mit unserem Klemmprofil können Sie sehr einfach Brüstungen mit linienförmiger Lagerung gemäß TRAV Kategorie C ausführen. Bitte beachten Sie das der Abstand der Klemmbacken maximal 300 mm betragen darf.

Balustrades with linear mounting according to TRAV category C can be realized quite easily, thanks to our clamp profiles. Please consider that the maximum distance between the brackets is about 300 mm.

- Auszug aus Tabelle 2 TRAV | extract from table 2 TRAV

| Kat. cat. | Typ type | Linienförmige Lagerung linear application | Breite width (mm) | | Höhe height (mm) | | Glasaufbau (mm) von innen nach außen glass build-up (mm) from inside to outside |
|-----------|----------------|---|---------------------|------------|--------------------|------|---|
| | | | min. | max. | min. | max. | |
| C1 und C2 | einfach single | Allseitig allseitig | 500 | 2000 | 500 | 1000 | 5 SPG/0,76 PVB/5 SPG |
| | | zweiseitig, oben und unten double sided, top and bottom | 1000 | bel. any | 500 | 800 | 6 SPG/0,76 PVB/6 SPG |
| C2 | | zweiseitig, links und rechts double sided, left and right | 800 | bel. any | 500 | 1000 | 5 ESG/0,76 PVB/5 ESG |
| | | | 800 | bel. any | 500 | 1000 | 8 SPG/1,52 PVB/8 SPG |
| | | | 500 | 800 | 1000 | 1100 | 6 SPG/0,76 PVB/6 SPG |
| | | | 500 | 1000 | 800 | 1100 | 6 ESG/0,76 PVB/6 ESG |
| | | | 500 | 1000 | 800 | 1100 | 8 SPG/1,52 PVB/8 SPG |



- Punkthalter nach TRAV | point fixings according to TRAV

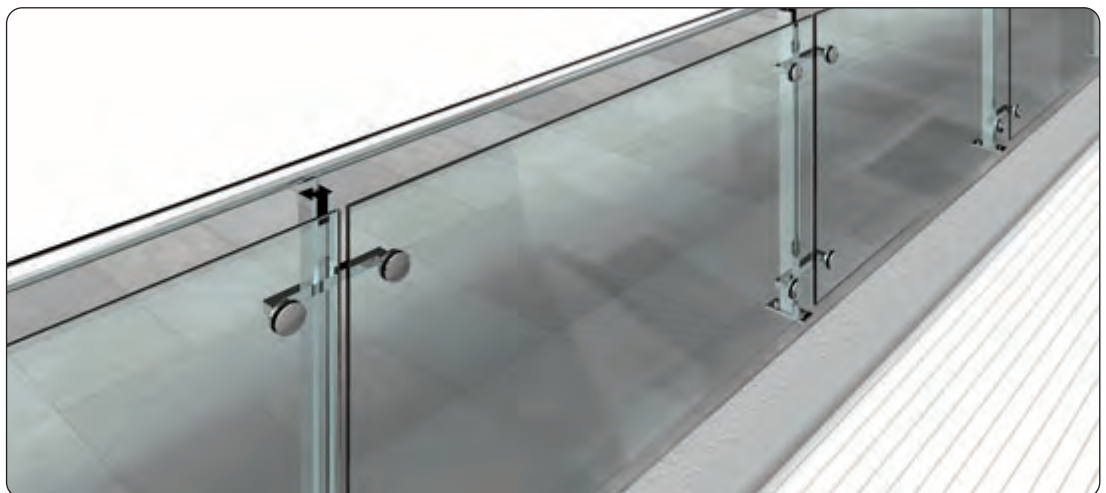

Viele Punkthalter können Sie nach den TRAV-Richtlinien verbauen. Für die Kategorie C1 müssen bestimmte Abmessungen eingehalten werden. Diese finden Sie auf dieser Seite.

Many point fixings can be installed according to the TRAV guidelines. For category C1, specific dimensions must be adhered to. These can be found on this page.



Brüstungsverglasung nach TRAV | balustrade glazing according to TRAV

■ Kategorie C1 | category C1

Punktförmig gelagerte Verglasungen der Kategorie C1 (Abschnitt 6.3.3) sind definiert wie folgt:

- Mit durchgehender Verschraubung und beidseitigen kreisförmigen Klemmtellern, jeweils im Eckbereich befestigte rechteckige Geländerfüllung (max. Höhe: 1000 mm), im Innenbereich aus VSG.
- Der Abstand der Glasbohrungsränder von den Glaskanten muss zwischen 80 und 250 mm liegen. Die Klemmteller müssen die Glasbohrungsränder min. 10 mm überdecken.
- Der direkte Kontakt zwischen Klemmtellern, Verschraubung und Glas ist durch geeignete Zwischenlagen (Zulagen bzw. Schlauchstücke aus Weich-PVC) zu verhindern. Jede Glashalterung muss eine statische Last von min. 2,8 kN aufnehmen können. Unsere TRAV-Halter sind natürlich für diese Last nachgewiesen.
- Werte zur Vordimensionierung können Sie aus unserer Tabelle entnehmen. Fordern Sie unsere Statik an.

Pointed category C1 fixed glazing (paragraph 6.3.3) is defined as:

- With continuous screw connections and circular clamping plates on both sides. The plates must be mounted in the corner areas. Rectangular attached LSG railing infill with a maximum height of 1000mm in the indoor area.
- The distance between the glass boring edges and glass edges must be 80 mm to 250 mm. The clamping plates must extend beyond the glass boring edges by at least 10 mm.
- Direct contact between clamping plates, screw connections and the glass should be prevented using suitable intermediate layers (inserts or soft PVC tube pieces). Each glass fixing must have a static load-bearing capacity of at least 2,8kN. Of course, our TRAV fixtures are verified for such a load.
- Values for pre-dimensioning can be taken from our table, request our static calculation.

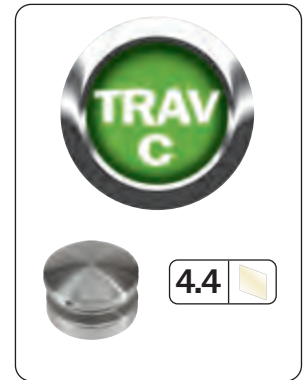

■ Kategorie C1 | category C1

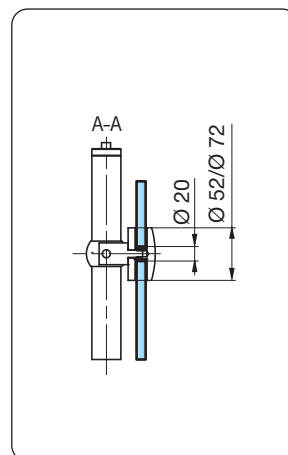
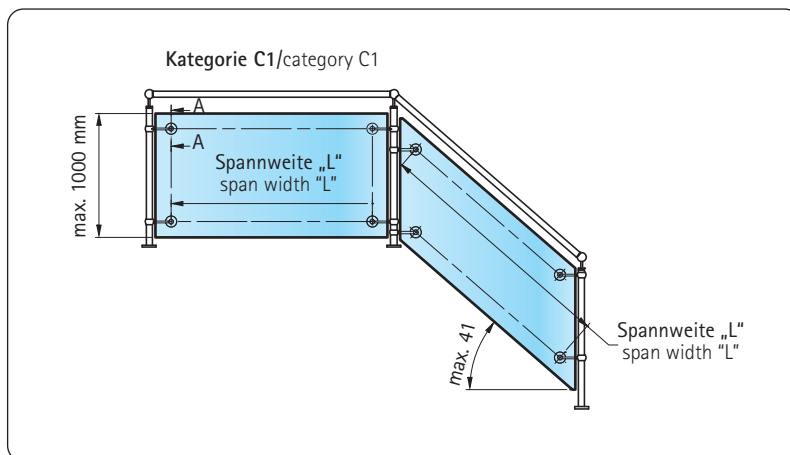

Die Ausführung von trapezförmigen Scheiben ist gemäß obiger Zeichnung nach TRAV möglich.

The execution of trapezoidal panels is possible according to the drawing above in accordance with the TRAV.

| TRAV C | |
|---|---|
| Tragfähigkeit load-bearing capacity | Glasstatik im Innenbereich nicht erforderlich glass statics not required in indoor area ✓ |
| Resttragfähigkeit residual load-bearing capacity | Versuchsbericht nicht erforderlich test report not necessary ✓ |
| ZiE bei Baubehörde ZiE from building authority | Im Innenbereich Antrag nicht erforderlich application not required in indoor area ✓ |
| Wir unterstützen Sie! We can support you! | |

■ Die in der Tabelle genannten Vorgaben für VSG-Scheiben sind einzuhalten. Für Rechteckscheiben bei maximaler Spannweite. | The details in the table for LSG panels must be adhered to. For rectangular panels with the maximum span width.

| Art. Nr. item no. | Teller Durchmesser plate diameter | Glasaufbau in mm glass structure in mm | Spannweite in mm span width in mm | | *max. Windlast *max. wind load |
|-----------------------------------|--------------------------------------|---|--------------------------------------|------|-----------------------------------|
| 7072VA 7076VA 7078VA 7016VA | ≥ 50 mm | ≥ 6 ESG/1,52 PVB/6 ESG | 500 | 1200 | 1,5 kN/m ² |
| 7073VA 7077VA | ≥ 70 mm | ≥ 8 ESG/1,52 PVB/8 ESG | 500 | 1600 | 1,5 kN/m ² |
| 7073VA 7077VA | ≥ 70 mm | ≥ 10 TVG/1,52 PVB/10 TVG | 500 | 1600 | 2,2 kN/m ² |
| 7072VA 7076VA 7078VA 7016VA | ≥ 50 mm | ≥ 8 ESG/1,52 PVB/8 ESG | 500 | 1200 | 2,8 kN/m ² |
| 7073VA 7077VA | ≥ 70 mm | ≥ 10 ESG/1,52 PVB/10 ESG | 500 | 1600 | 2,5 kN/m ² |

*Nur bei Anwendungen im Außenbereich zu berücksichtigen. Dadurch wird zusätzlich eine Zustimmung im Einzelfall erforderlich. Fordern sie unsere Statik an. | *Solely in respect of outdoor use. For applications in outdoor areas, an additional individual approval (ZiE) is required. Request our static calculation.

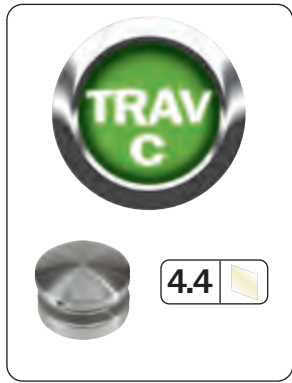

Brüstungsverglasung nach TRAV | balustrade glazing according to TRAV

- Brüstungsverglasung nach TRAV Kategorie C1 | balustrade glazing according to TRAV category C1



Gemäß TRAV müssen auch die Laschen, an denen die TRAV-Punkthalter befestigt sind, für eine Last von 2,8 kN ausgelegt sein. Unsere TRAV-Laschen erfüllen natürlich diese Anforderungen. (Nachweis versuchs-technisch, Versuchsbericht in Vorbereitung)

According to TRAV must the mounting links, which fasten the TRAV point fixtures, also be appropriate for a load of 2.8kN. Our TRAV - mounting links do of course meet this demand. (test-confirmed, test report in preparation)



Brüstungsverglasung nach TRAV | balustrade glazing according to TRAV

- Brüstungsverglasung nach TRAV Kategorie B | balustrade glazing according to TRAV category B



Bei der Brüstungsverglasung nach TRAV Kategorie B handelt es sich um eine an ihrem unteren Rand in einer Klemmkonstruktion linienförmig gelagerte, tragende Glasbrüstung, deren einzelnen Scheiben durch einen aufgesteckten durchgehenden Handlauf verbunden sind.

Glazing according to TRAV category B involve: load-bearing glass balustrades that are linearly installed with a clamp construction on their lower edge and have an attached handrail linking their panels.

| | |
|---|--|
| Tragfähigkeit load-bearing capacity | Statik erforderlich static calculation required |
| → | ✗ |
| Resttragfähigkeit residual load-bearing capacity | TRAV |
| → | ✓ |
| ZiE bei Baubehörde ZiE from building authority | Antrag nicht erforderlich application not required |
| → | ✓ |

Wir unterstützen Sie!
We can support you!

| Breite in mm width in mm | | Höhe in mm height in mm | | Glasaufbau in mm glass structure in mm |
|-----------------------------|------|----------------------------|------|---|
| min. | max. | min. | max. | |
| 500 | 2000 | 900 | 1100 | ≥ (10 ESG/1,52 PVB/10 ESG) |
| 500 | 2000 | 900 | 1100 | ≥ (10 TVG/1,52 PVB/10 TVG) |

Da die Holmlast direkt in die Glasscheibe eingeleitet wird, ist eine statische Berechnung des Glases erforderlich.

Since the rail load will pass into the glass panel, a static calculation of the glass is required.

Brüstungsverglasung nach TRAV | balustrade glazing according to TRAV

■ Kategorie B | category B



Bei der Brüstungsverglasung nach TRAV Kategorie B gibt es unterschiedliche Möglichkeiten der Anwendung. Wir stellen Ihnen zwei Systeme vor. Die links dargestellte Brüstung mit einer linienförmigen Einspannung entspricht der TRAV Kategorie B. Bei dem rechten System ist wegen der punktuellen Lagerung unten eine Zustimmung im Einzelfall erforderlich.



There are different application possibilities in respect of balustrade glazings under TRAV category B. Two systems are shown here. On the left is a linear supported system according to TRAV category B. On the right is a system that requires individual approval due to the point fixings in the lower area.

■ Nutrohr Handlauf | Slotted tube handrail



Bei diesem Produkt handelt es sich um ein TRAV-konformen Handlauf nach Kategorie B, für VSG 20 mm mit PVB 1,52 mm und mit einem Glaseinstand von mindestens 15mm. Es darf VSG aus 2x10 mm ESG oder 2x10 mm TVG verwendet werden. Der Kontakt zwischen Glas und Metall wird durch das Aufstecken von einem Elastomer-Profil (Abstand ca. 200-300 mm) auf die Scheibe verhindert. Die Verbindung des Handlaufes mit den Scheiben erfolgt durch die Füllung des verbleibenden Hohlraumes im U-Profil mit Dichtstoffen nach DIN 18 545-2 Gruppe E.



This product is a TRAV-compliant category B handrail for 20 mm laminated safety glass with 1,52 mm PVB and a glass mounting depth of at least 15 mm. Laminated safety glass with 2 x 10 mm tempered or heat-strengthened safety glass may be used. Glass/metal contact is prevented by attaching an elastomeric profile (with a gap of approx. 200-300 mm to the glass panel). The handrail is connected to the handrail with the glass panel by filling the remaining cavity in the U-profile with sealants in accordance with DIN 18 545-2 Group E.

| | | |
|--|--|------------|
| | | 4.6 |
| Tragfähigkeit load-bearing capacity | Statik erforderlich static calculation required | ✗ |
| Resttragfähigkeit residual load- bearing capacity | TRAV | ✓ |
| ZiE bei Baube- hörde ZiE from building authority | Antrag nicht erforder- lich application not required | ✓ |
| Wir unterstützen Sie! We can support you! | | |

| | | |
|--|--|---|
| | | |
| Tragfähigkeit load-bearing capacity | Statik erforderlich static calculation required | ✗ |
| Resttragfähigkeit residual load- bearing capacity | Versuchsbericht in Vorbereitung test report in preparation | ✓ |
| ZiE bei Baube- hörde ZiE from building authority | Antrag erforderlich application required | ✗ |
| Wir unterstützen Sie! We can support you! | | |

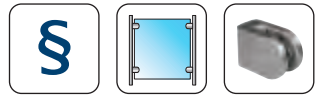

Zustimmung im Einzelfall | individual approval

Der einfache Weg zur ZiE | The easy way to obtain a ZiE

KURZ | IN BRIEF

„Zustimmung im Einzelfall“ ist für viele Planer zunächst sehr abschreckend. Wenn aber alle erforderlichen Unterlagen, wie z. B. Versuchsberichte oder Statiken bereits vorliegen, ist eine ZiE in der Regel sehr schnell und günstig zu erwirken.

„Approval for individual case“ (ZiE) seems very daunting to many planners. But if all necessary documents are on hand, like test-reports or statics, then it is quite simple to get a ZiE.

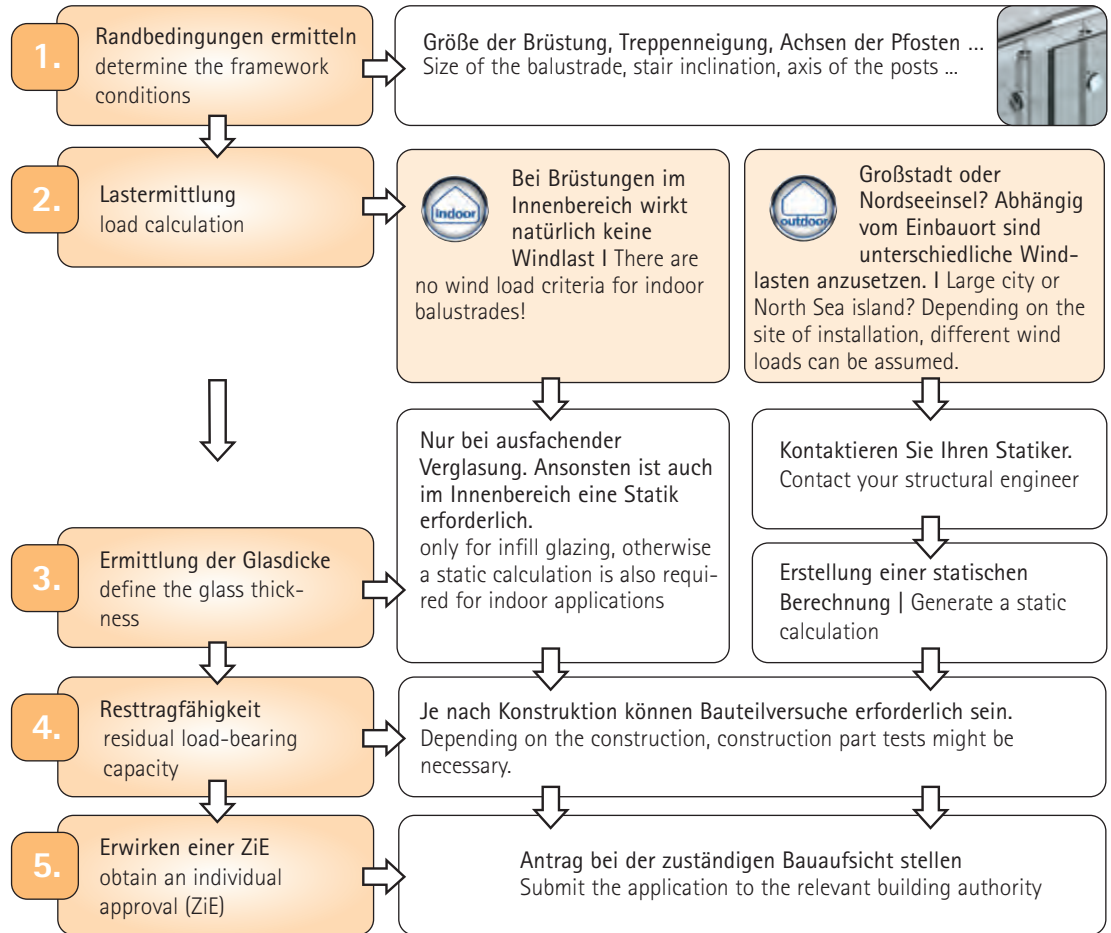

Brüstungen mit cp-mini | balustrades with cp-mini

Klar, einfach und zeitlos | precise, simple and timeless

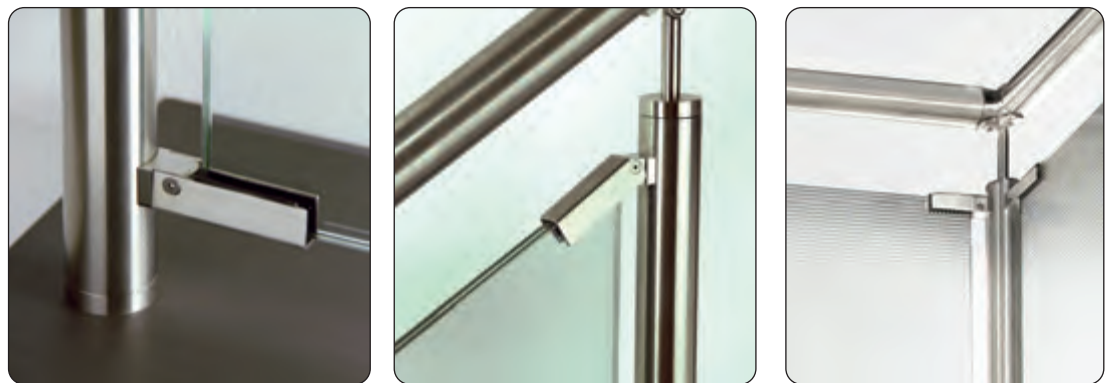

Bei cp-mini wurde konsequent der Grundsatz von hohem architektonischen Anspruch und Transparenz bei maximaler Sicherheit verwirklicht. Der filigrane Edelstahlhalter ist kaum sichtbar und hat ein durchdachtes Innenleben. cp-minis sind einsetzbar für Brüstungsverglasungen mit Glasbreiten von 500 bis zu 1400 mm. Die Halter sind abgestimmt auf rechtwinklige Scheiben sowie auf Parallelogramme wie z. B. bei Treppenläufen. Zudem sind sie einsetzbar für die Befestigung an geraden und runden Pfosten.

With cp-mini, we have brought to life the principle of intricate architectural standards and transparency, together with the maximum safety. The filigree stainless steel fixing is hardly visible and has the sophisticated inner workings. cp-minis can be used for balustrade glazing with glass widths of up to 1400 mm. The fixings are designed for right-angled panels and parallelograms such as flights of stairs. The fixings can also be used for attachment to straight and round posts.

| | |
|--|---|
| Tragfähigkeit load-bearing capacity | Glasstatik im Innenbereich nicht erforderlich glass statics not required for indoor use ✓ |
| Resttragfähigkeit Glas residual load-bearing capacity of the glass | Versuchsbericht vorhanden test report available ✓ |
| ZiE bei Baubehörde ZiE from building authority | Antrag erforderlich application required ✗ |

Wir unterstützen Sie! We can support you!



Brüstungen mit cp-mini | balustrades with cp-mini

- Anwendungsbedingungen cp-mini gemäß Versuchsbericht
application conditions according to test report

| Art. Nr. item no. | Rohr tube | Glasaufbau glass structure in mm | Spannweite min. - max. min. - max. span width in mm |
|---|--------------|--|---|
| 9410VA 9411VA 9412VA 9413VA 9414VA | | ≥ 6 ESG/1,52 PVB/6 ESG | 500 - 1400 |
| 9420VA 9421VA 9422VA 9423VA 9424VA | | ≥ 6 ESG/1,52 PVB/6 ESG | 500 - 1400 |

Französischer Balkon ohne Handlauf | french balcony without hand rail

- Mit TRAV-Haltern | with TRAV fixtures

Unsere TRAV-Halter sind auch für die Anwendungen als französischer Balkon ohne Handlauf geeignet. Eine Beispielabmessung sehen Sie hier. Die erforderlichen Bauteilversuche wurden erfolgreich durchgeführt.

Our TRAV fixtures are also suitable for applications with a French balcony without a handrail. An example is shown here. The necessary parts testing was successfully performed.

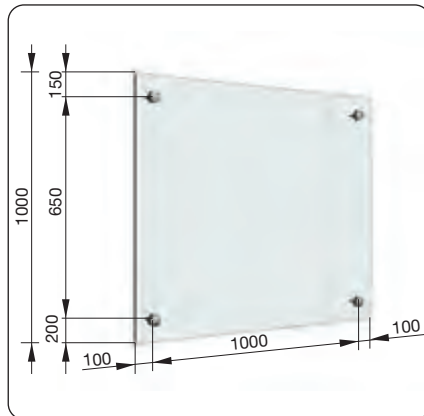

Beispielabmessungen der Glasscheibe - 1000 x 1200 mm
Glasaufbau: VSG = 2x6 mm TVG, 1,52 mm PVB-Folie,
Punkthalter: 7072VA
Versuchsbericht liegt vor

Example of the glass panel dimensions - 1000 x 1200 mm
Glass structure: LSG = 2x6 mm heat-strengthened safety
glass, 1,52 mm PVB film Point fixings: 7072VA
test report is on hand

- Mit linienförmiger Lagerung | with linear mounting



Auch mit unserem neuen Linienprofil ist die Ausführung von französischen Balkonen sehr einfach realisierbar.
It is quite easy to realize french balconies with our new linear profiles.

| ZiE Geprüft im ZiE | |
|--|---|
| Tragfähigkeit load-bearing capacity | Statik erforderlich static calculation required |
| Resttragfähigkeit residual load- bearing capacity | Versuchsbericht vorhanden test report available * |
| ZiE bei Baube- hörde ZiE from building authority | Antrag erforderlich application required |
| Wir unterstützen Sie! We can support you! | |

*für ausgewählte Formate
for selected dimensions

| ZiE Geprüft im ZiE | |
|--|---|
| Tragfähigkeit load-bearing capacity | Statik erforderlich static calculation required |
| Resttragfähigkeit residual load- bearing capacity | Versuchsbericht nicht vorhanden test report not available |
| ZiE bei Baube- hörde ZiE from building authority | Antrag erforderlich application required |
| Wir unterstützen Sie! We can support you! | |



Weitere Alternativen | other alternatives

- Querstabhalter | cross bar holders



Kontaktieren Sie Ihre Bauaufsichtsbehörde wegen der jeweiligen Anforderungen!

Contact your building authorities about the relevant requirements.

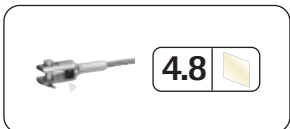

- Seile | Cables







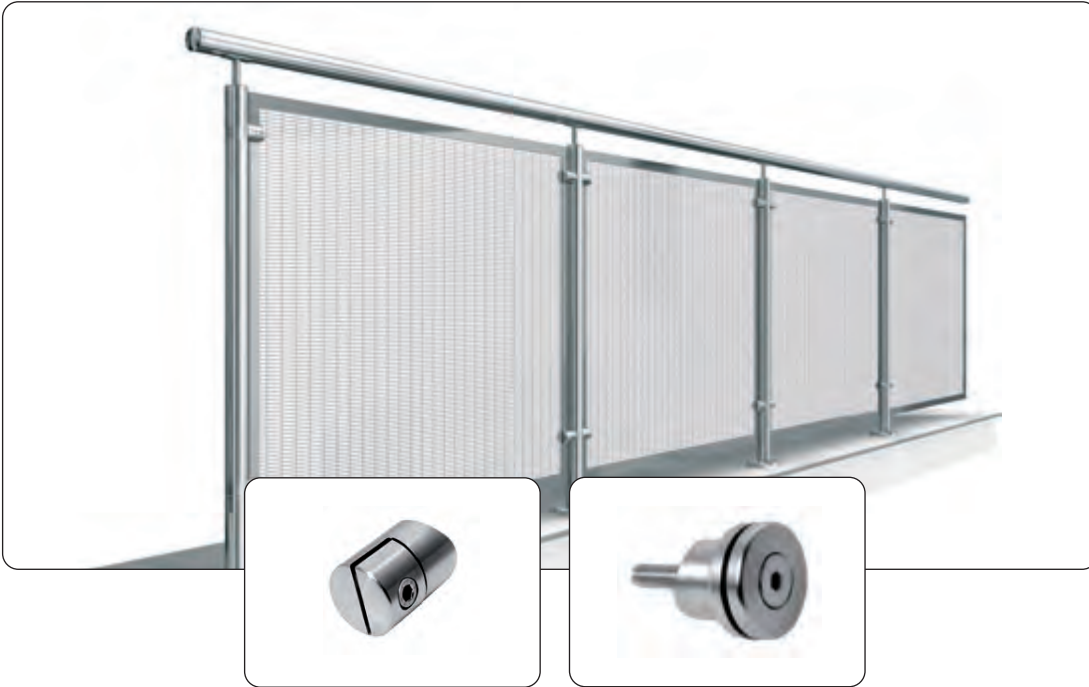

Kontaktieren Sie Ihre Bauaufsichtsbehörde wegen der jeweiligen Anforderungen!

Contact your building authorities about the relevant requirements.



Lochblechhalter | sheet holders



| | |
|---|--|
|   | |
| Tragfähigkeit Füllung load-bearing capacity of the infill | Statik innen nicht erforderlich statics not necessary in indoor applications  |
| Resttragfähigkeit Füllung residual load-bearing capacity of the infill | Versuche nach ETB tests according to ETB  |
| ZiE bei Baubehörde ZiE from building authority | Antrag erforderlich application required  |
|  Wir unterstützen Sie! We can support you! | |



Farbigkeit | colour

- Brillanz in vielen Nuancen | brilliance in many shades

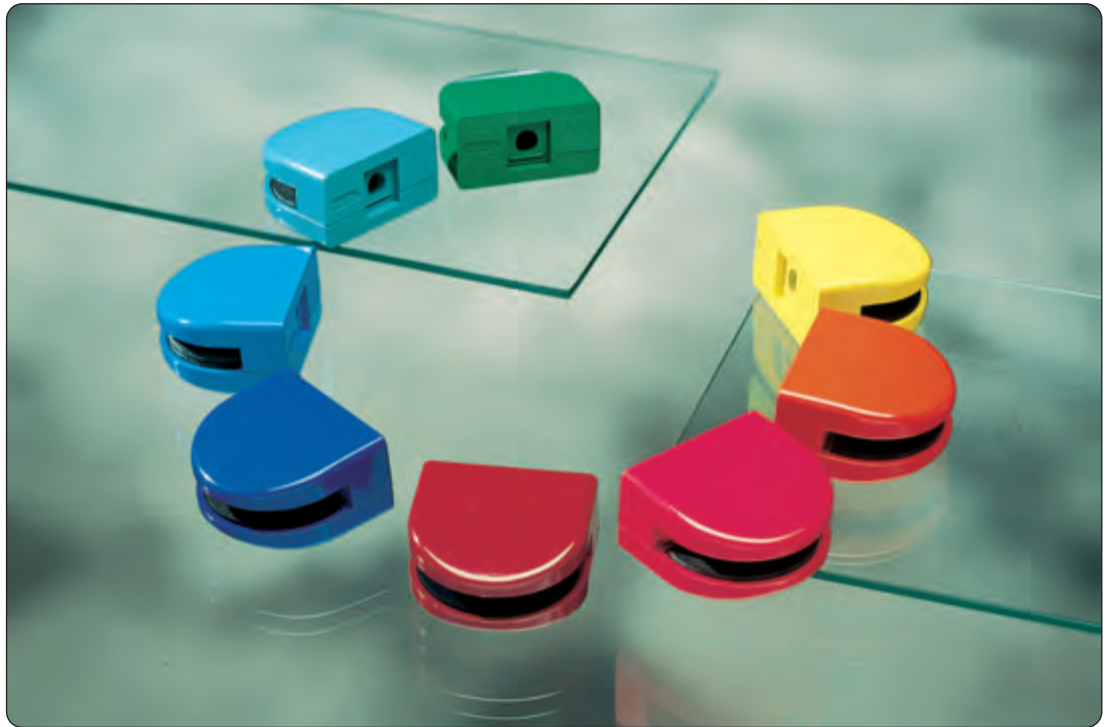

Wir stellen uns flexibel auf Ihre besonderen Wünsche ein und realisieren diese in kürzester Zeit, auch in großen Stückzahlen. Die zeitgemäße Beschichtungstechnologie für Glasbeschläge bringt jeden gewünschten Farbton in einmaliger Brillanz auf Ihre Beschlagsversion. Und trotz schneller Lieferzeit achten wir stets darauf, bei der Qualität unserer Produkte keine Kompromisse einzugehen – made in Germany.

We can react flexibly to your particular wishes and realise them in a very short time, even in large quantities. Modern coating technology for glass fittings brings every desired shade in unique brilliance to your fittings. And in spite of the quick delivery time, we always take care that the quality of our products is never compromised – made in Germany.

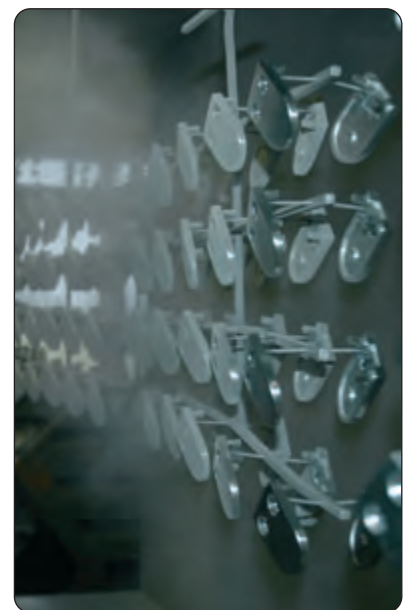



Farbigkeit | colour

Farben und Beschichtungen für den Innenbereich | colours and surfaces for indoor applications

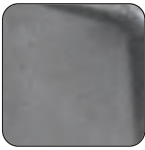

02 Zink roh
rough zinc



03 Zink geschliffen,
poliert, mattverchromt
ground, polished zinc,
matt chrome finish



09 Zink geschliffen, poliert,
glanzverchromt
ground, polished zinc,
bright chrome finish



14 Zink geschliffen, poliert,
glanzvergoldet
ground, polished zinc,
bright gold finish



04 Zink alufarbig, pulver-
beschichtet
aluminium-colour zinc,
powder coated



15 Zink weiß RAL 9016,
pulverbeschichtet
white RAL 9016 zinc,
powder coated

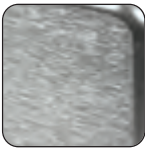

05 Zink geschliffen, matt-
verchromt (Edelstahl-
effekt) | ground zinc,
matt chrome finish
(stainless steel effect)

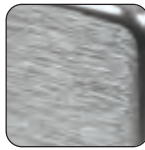

06 Zink geschliffen, matt-
verchromt (Edelstahl-
effekt), mit Klarlack
ground zinc, matt chrome
finish (stainless steel
effect), with clear lacquer



07 Zink Edelstahlfinish
zinc stainless steel finish

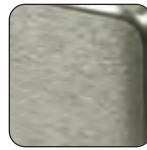

08 Zink Edelstahlfinish, mit
Klarlack | zinc stainless
steel finish, with clear
lacquer



13 Zink Edelstahlfinish (Zn22),
Zink Dreieck glanzver-
chromt (Zn5) | zinc stain-
less steel finish (Zn22),
ground zinc triangle, bright
chrome finish (Zn5)



12 Zink Edelstahlfinish (Zn22),
Zink Dreieck geschliffen,
mattvermessingt (Zn2-G)
zinc stainless steel finish
(Zn22), ground zinc triangle,
matt brass finish (Zn2-G)



22 Edelstahl matt
geschlichtet
stainless steel turned
finish



10 Edelstahl poliert
polished stainless steel



11 Edelstahl matt gebürstet
matt brushed stainless
steel

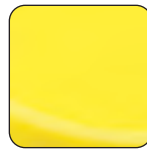

01 pulverbeschichtet in RAL-Farben
powder coated in RAL colours



Farben und Beschichtungen für den Außenbereich | colours and surfaces for outdoor applications

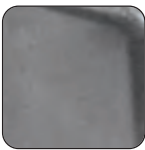

02 Zink roh
rough zinc



09 Zink geschliffen,
poliert, glanzverchromt
ground, polished zinc,
bright chrome finish



04 Zink alufarbig, pulver-
beschichtet
aluminium-coloured
zinc, powder coated



15 Zink weiß RAL 9016,
pulverbeschichtet
white RAL 9016 zinc,
powder coated

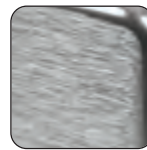

06 Zink geschliffen, matt-
verchromt (Edelstahl-
effekt), mit Klarlack
ground zinc, matt chrome
finish (stainless steel
effect), with clear lacquer



08 Zink Edelstahlfinish, mit
Klarlack | zinc stainless
steel finish, with clear
lacquer



22 Edelstahl matt
geschlichtet
stainless steel turned
finish



10 Edelstahl poliert
polished stainless steel



11 Edelstahl matt gebürstet
matt brushed stainless
steel



01 pulverbeschichtet in RAL-Farben
powder coated in RAL colours



■ Anwendungen | applications AbZ 7-70.2-28



Berlin, 2008



Nürnberg, 2008



■ Anwendungen mit ZiE | applications where individual approval is required



Studio 3001, 2009

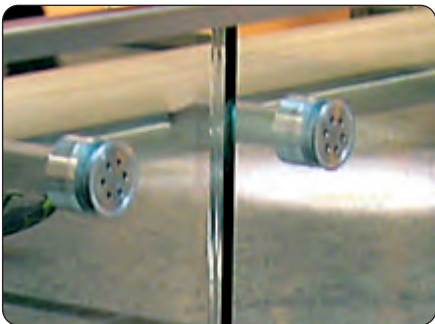

Berlin, 2009

