

WSS-Sliding Door Systems
SPRINT - Design Line



Features:

- suitable for single and double leaf all-glass doors
- wall or glass installation
- ceiling fixation on request
- **stainless steel V2A, brushed**
- simple glass preparation

Technical details:

Glass:	8, 10 and 12 mm ESG
Leaf weight:	max. 100 kg (ESG made from uncoated Float glass)
Track:	Ø 25 mm
Height adjustability:	± 2,5 mm (eccentric suspensions)
Test:	100.000 cycles according to DIN EN 1527 / class 6

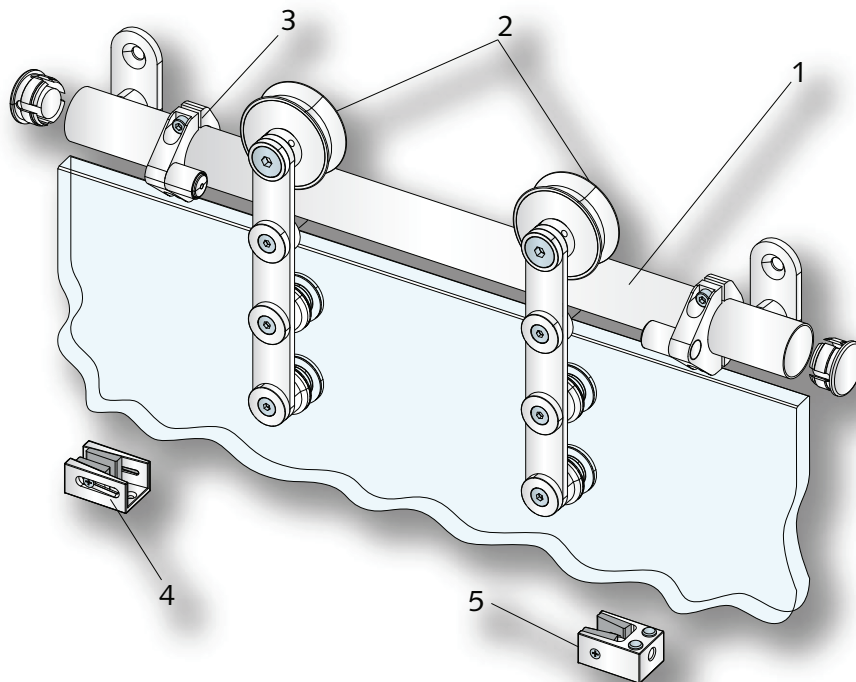

Components: 1. track with wall fixing, 2. carriers, 3. endstops, 4. floor guide, 5. floor stop

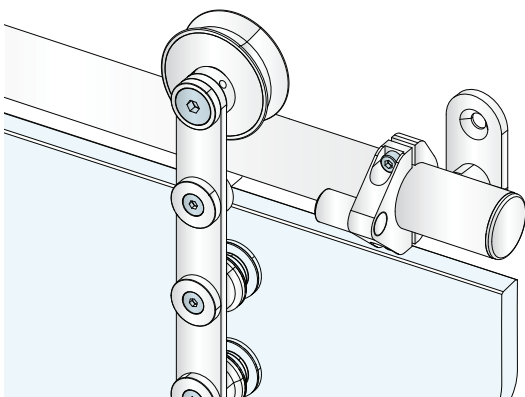

The holders allow a fast and secure wall installation of the track (track with wall fixing).

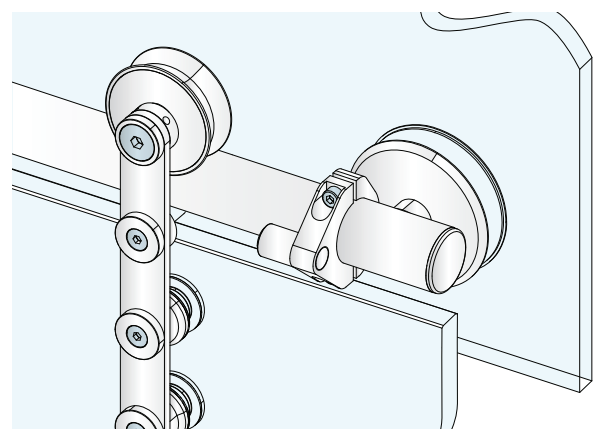

The clamping surfaces optimally disperse the pressure to the glass (track with glass fixing).

Sectional view:

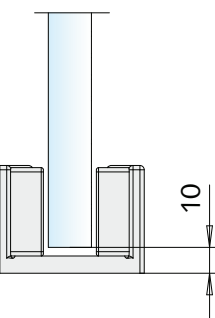
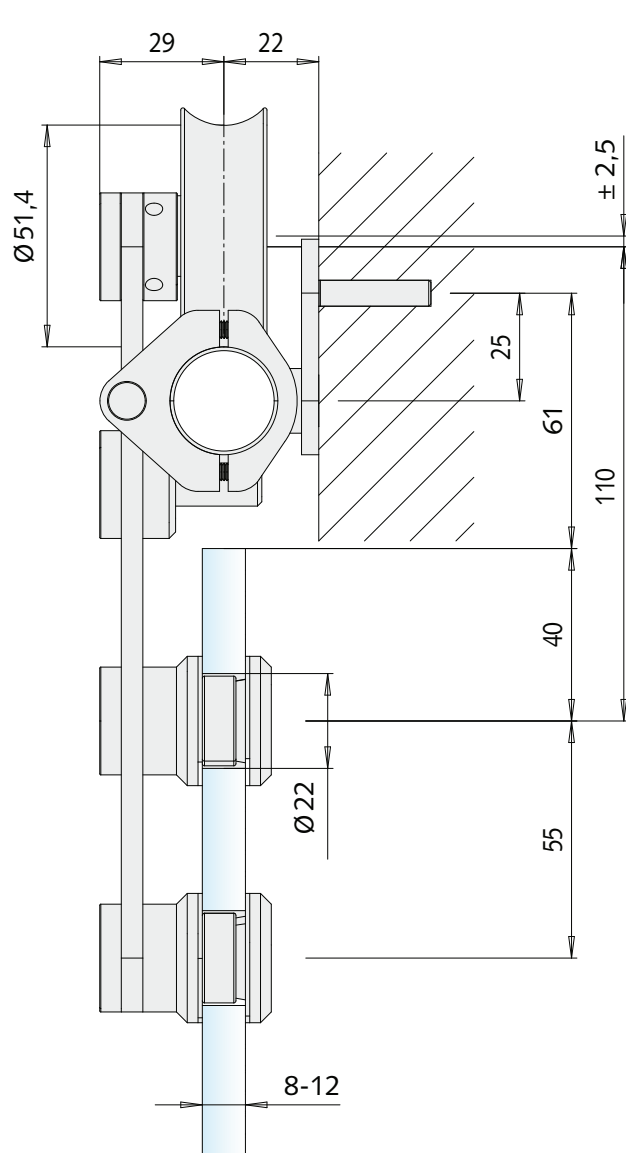

Wall fixing

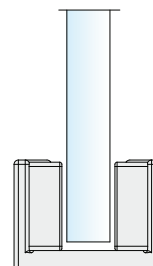
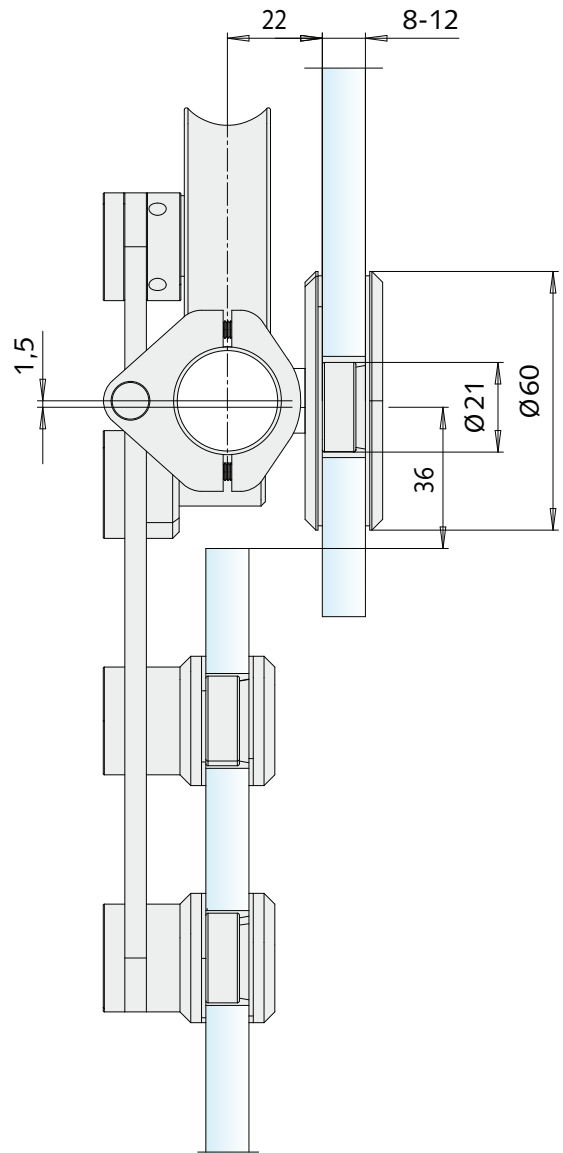

Glass fixing

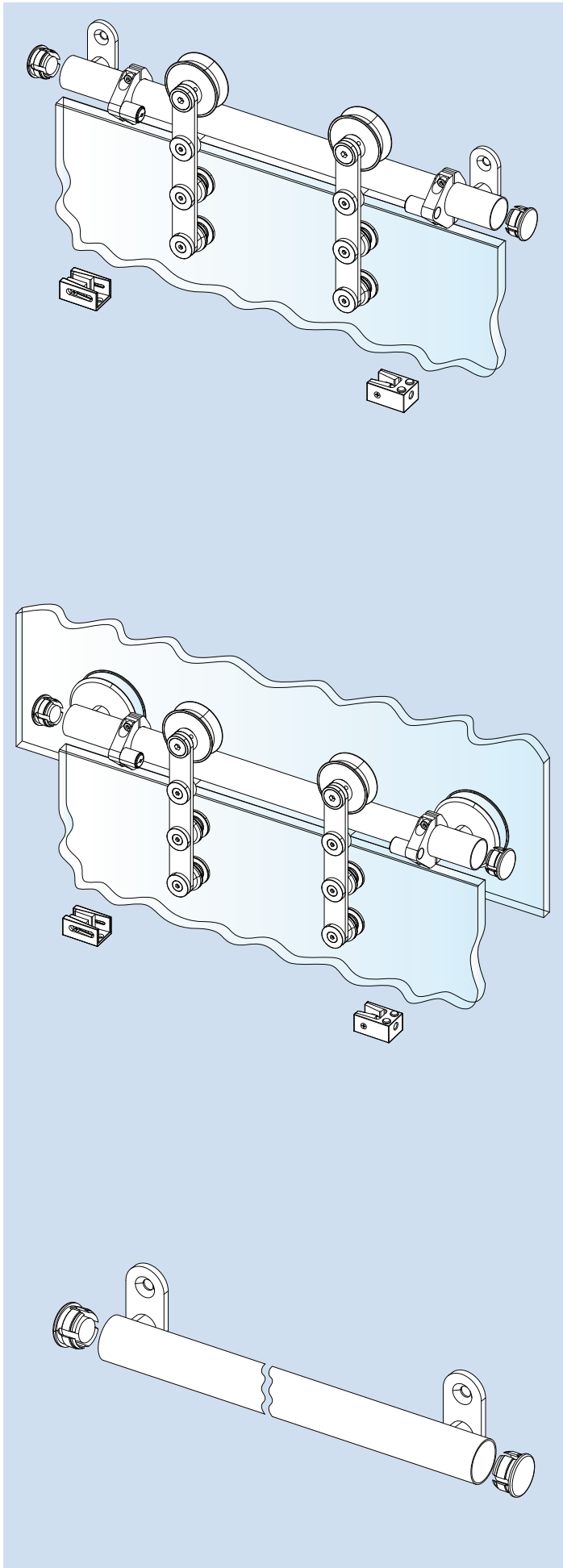

Sliding door set, for single leaf doors

- max. leaf weight 100 kg
- for 8 - 12 mm glass
- 1 track with **wall fixing**, 2 carriers,
2 endstops, 1 floor guide, 1 floor stop

Art-N°.	Track	Material/Surface
28.801.0600.426	1.940 mm	stainless steel V2A, brushed
28.803.0600.426	2.140 mm	stainless steel V2A, brushed
28.805.0600.426	2.340 mm	stainless steel V2A, brushed
28.807.0600.426	2.540 mm	stainless steel V2A, brushed

Information	Sliding door set cut to size:
	Track with wall fixing: Art-N° 28.909.0000.426
	Accessory-Set: Art-N° 28.920.0600.426

Information	Glass preparation:	page 34

Sliding door set, for single leaf doors

- max. leaf weight 100 kg
- for 8 - 12 mm glass
- 1 track with **glass fixing**, 2 carriers,
2 endstops, 1 floor guide, 1 floor stop

Art-N°.	Track	Material/Surface
28.811.0600.426	1.940 mm	stainless steel V2A, brushed
28.813.0600.426	2.140 mm	stainless steel V2A, brushed
28.815.0600.426	2.340 mm	stainless steel V2A, brushed
28.817.0600.426	2.540 mm	stainless steel V2A, brushed

Information	Sliding door set cut to size:
	Track with glass fixing: Art-N° 28.919.0000.426
	Accessory-Set: Art-N° 28.920.0600.426

Information	Glass preparation:	page 34 - 35

Track with wall fixing

- Ø 25 mm
- with plugs

Art-N°.	Length	Material/Surface
28.901.0000.426	1.940 mm	stainless steel V2A, brushed
28.903.0000.426	2.140 mm	stainless steel V2A, brushed
28.905.0000.426	2.340 mm	stainless steel V2A, brushed
28.907.0000.426	2.540 mm	stainless steel V2A, brushed
28.909.0000.426	cut to size	stainless steel V2A, brushed

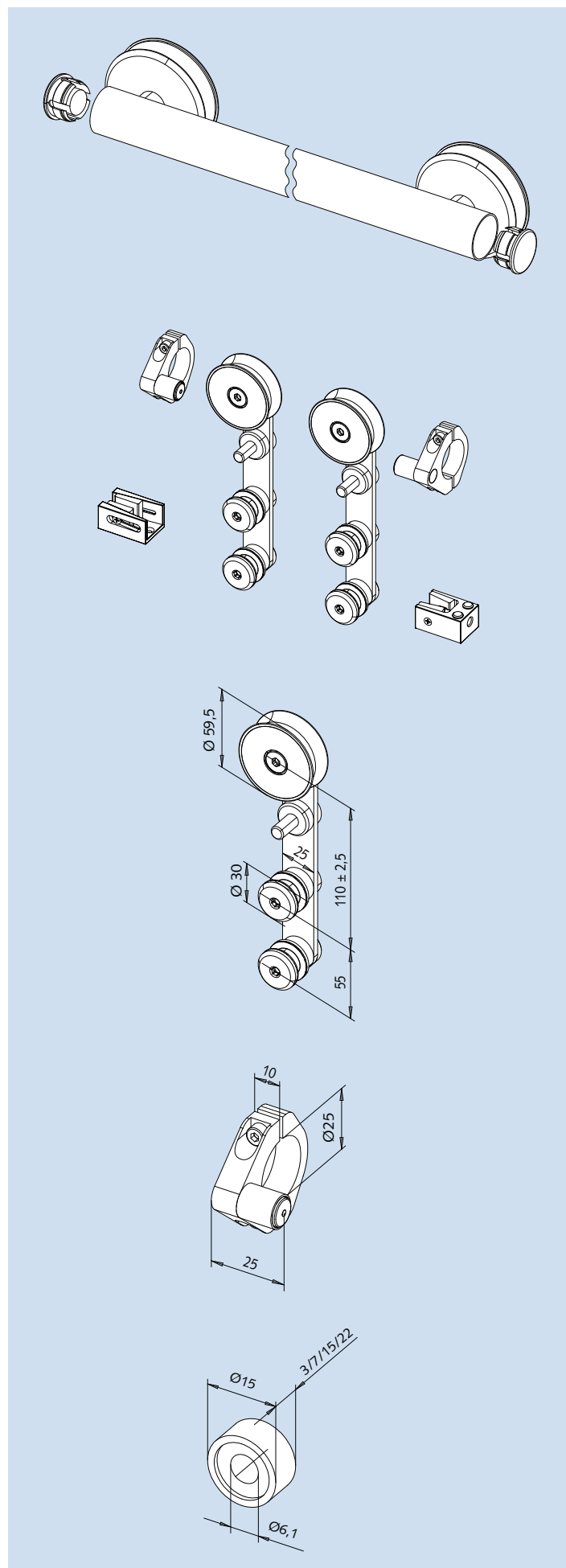

Track with glass fixing

- Ø 25 mm
- with plugs

Art-N°.	Length	Material/Surface
28.911.0000.426	1.940 mm	stainless steel V2A, brushed
28.913.0000.426	2.140 mm	stainless steel V2A, brushed
28.915.0000.426	2.340 mm	stainless steel V2A, brushed
28.917.0000.426	2.540 mm	stainless steel V2A, brushed
28.919.0000.426	cut to size*	stainless steel V2A, brushed

Information Glass preparation: [page 35](#)

*) When ordering sliding door systems cut to size, WSS provides an individual drawing of the glass preparation.

Accessory-Set

- for 8 - 12 mm glass
- 2 carriers, 2 endstops, 1 floor guide, 1 floor stop

Art-N°.	Material/Surface
28.920.0600.426	stainless steel V2A, brushed

Information Glass preparation: [page 34](#)

Carrier

- for 8 - 12 mm glass

Art-N°.	Material/Surface
28.930.0600.426	stainless steel V2A, brushed

Information Glass preparation: [page 34](#)

Endstop

Art-N°.	Material/Surface
28.940.0600.426	stainless steel V2A, brushed

Wall spacer

Art-N°.	Execution	Material/Surface
28.950.0000.426	3 mm	stainless steel V2A, brushed
28.952.0000.426	7 mm	stainless steel V2A, brushed
28.954.0000.426	15 mm	stainless steel V2A, brushed
28.956.0000.426	22 mm	stainless steel V2A, brushed